



Warranty & Start-Up Information

Job Name:

Toll-Free 24/7 Technical Support Line: 1.800.523.9466

Job Number:

Field Service Scheduling 1.800.523.9466 ext.4439

Lutron Standard Limited Warranty

Applies to all Lutron Products that are not purchased with Lutron Services Co., Inc. start-up.

Limited Warranty

Lutron warrants each new unit to be free from defects in materials and workmanship and to perform under normal use and service.

Lutron will, at its option, repair or replace any unit that is defective in materials or manufacture within one year after purchase. For Lutron ballasts, Lutron will repair or replace any unit that is defective in materials or manufacture within three years after purchase.

THIS WARRANTY IS IN LIEU OF ALL OTHER EXPRESS WARRANTIES, AND THE IMPLIED WARRANTY OF MERCHANTABILITY IS LIMITED TO ONE YEAR FROM PURCHASE. THIS WARRANTY APPLIES ONLY TO LUTRON HARDWARE AND DOES NOT INCLUDE LUTRON SOFTWARE, LUTRON PROVIDED SYSTEM SERVERS, LAPTOPS, PDAS, OR COMPUTERS PURCHASED WITH LUTRON CONTROL SYSTEMS. THIS WARRANTY DOES NOT COVER THE COST OF INSTALLATION, REMOVAL, OR REINSTALLATION, OR DAMAGE RESULTING FROM MISUSE, ABUSE, OR IMPROPER OR INCORRECT REPAIR, OR DAMAGE FROM IMPROPER WIRING OR INSTALLATION. THIS WARRANTY DOES NOT COVER INCIDENTAL, OR SPECIAL DAMAGES. THE PURCHASER ASSUMES AND WILL HOLD HARMLESS LUTRON IN RESPECT OF ALL SUCH LOSS. LUTRON'S LIABILITY ON ANY CLAIM FOR DAMAGES ARISING OUT OF OR IN CONNECTION WITH THE MANUFACTURE, SALE, INSTALLATION, DELIVERY, OR USE OF THE UNIT SHALL NEVER EXCEED THE PURCHASE PRICE OF THE UNIT.

This warranty gives you specific legal rights, and you may also have other rights which vary from state to state. Some states do not allow limitations on how long an implied warranty lasts, so the above limitation may not apply to you. Some states do not allow the exclusion or limitation of incidental or consequential damages, so the above limitation or exclusion may not apply to you.

For warranty service on returnable products (including Lutron ballasts), take the unit to the place of purchase or mail to:

Lutron
7200 Suter Rd.
Coopersburg, PA 18036-1299
(send postage pre-paid for proper handling)

For warranty service on non-returnable products, contact Lutron Technical Support Center at
1-800-523-9466

Note - Although every attempt is made to ensure that catalog information is accurate and up-to-date, please check with Lutron before specifying or purchasing this equipment to confirm availability, exact specifications, and suitability for your application.

©2009 Lutron Electronics Co., Inc.

<p>Job Name:</p> <p>Job Number:</p>	<p>Model Numbers:</p>
--	------------------------------

Lutron Electronics Co., Inc. Commercial Systems Limited Warranty

SCOPE

This limited warranty ("Warranty") covers Lutron (a) commercial lighting control system panels, controls, processor panels, wall box products, and other Lutron components (collectively, "Hardware"), (b) ballasts supplied directly by Lutron ("Ballasts"), (c) provided computer ("Supplied Computer"), and (d) commercial systems eLumen software ("Software" and, with the Hardware, Ballasts and Supplied Computer, the "System"). Customer acknowledges and agrees that use of (i) the System, or any part thereof, constitutes acceptance of all terms and conditions of this Warranty and (ii) the Software is subject to the terms and conditions of Lutron's Software License. Any subsequent addition to the System provided by Lutron will be governed by a separate warranty issued at the time of the purchase of the additional equipment.

The provisions of this Warranty applicable to the Supplied Computer and Software will not apply to Systems that do not include these components.

LIMITED WARRANTY

Subject to the exclusions and restrictions and for the periods of time described in this Warranty, Lutron warrants that the System will be free from manufacturing defects. If any manufacturing defect exists in any Hardware or Ballast during the period of time identified below from the date of start-up completion by Lutron or a Lutron approved third party, or the date of shipment by Lutron if such component was not purchased with Lutron start-up, so long as Customer promptly notifies Lutron of the defect and, if requested by Lutron, upon the return of the defective part(s), Lutron will, at its option, either repair the defective part(s) or issue a credit to the Customer against the purchase price of comparable replacement part(s) purchased from Lutron as follows:

Number of Years from Date of Start-up or Shipment, as applicable	Percentage of Part Price Credited by Lutron			
	Hardware		Ballasts	
	With Start-up	No Start-up	With Start-up	No Start-up
Up to 1	100%	100%	100%	100%
More than 1 but not more than 2	100%	0%	100%	100%
More than 2 but not more than 3	50%	0%	100%	100%
More than 3 but not more than 5	50%	0%	100%	0%
More than 5 but not more than 8	25%	0%	0%	0%
More than 8	0%	0%	0%	0%

If any manufacturing defect exists in the Supplied Computer or Software during the one year period from the date of start-up by Lutron or a Lutron approved third party, or the date of shipment by Lutron if component was not purchased with Lutron start-up, so long as Customer promptly notifies Lutron of the defect, upon the return of the defective part(s) as to the Supplied Computer, if requested by Lutron, or Lutron determining that a defect exists as to the Software, Lutron will, at its option, either repair the defective part(s) or provide comparable replacement part(s).

Replacement parts for the System provided by Lutron or, at its sole discretion, an approved vendor may be new, used, repaired, reconditioned, and/or made by a different manufacturer.

CUSTOMER OBLIGATIONS TO MAINTAIN LIMITED WARRANTY

This Warranty will be void, and Lutron will have no obligations under it unless Customer complies with all of the following:

1. The Supplied Computer must be installed and maintained in a secure location, within the

Job Name:	Model Numbers:
Job Number:	

temperature and relative humidity ranges specified in the documentation accompanying the Supplied Computer, and away from where it may be bumped, abused, or subjected to large amounts of dust or dirt.

2. The Supplied Computer must be connected to a reliable (and preferably generator or battery backed-up) power supply.
3. The Supplied Computer must be properly shutdown in the event of power loss to prevent damage to it or its data, either of which could prevent it from operating properly. Customer has sole responsibility to take all reasonable measures to prevent this from occurring.
4. No modification, alteration, adjustment or repair can be made to the Software except by, or at the express instruction of, Lutron.
5. The Software may not be used on any hardware except the Supplied Computer.
6. No third party software may be installed on the Supplied Computer.

Lutron does not warrant that the Software will operate in combination with any other software except as specified in the applicable Lutron documentation. Customer acknowledges that its use of the Software may not be uninterrupted or error-free.

To ensure optimal operating conditions for the System, Lutron recommends that the Supplied Computer (1) not be connected to a power source that is also supplying power to a motor or other load that causes significant conducted emissions; (2) be located to permit easy access to it; and (3) be placed on a dedicated circuit.

EXCLUSIONS AND RESTRICTIONS

This Warranty does not cover, and Lutron and its suppliers are not responsible for:

1. Damage, malfunction or inoperability diagnosed by Lutron or a Lutron approved third party as caused by normal wear and tear, abuse, misuse, incorrect installation, neglect, accident, interference or environmental factors, such as (a) use of incorrect

line voltages, fuses or circuit breakers; (b) failure to install, maintain and operate the System pursuant to the operating instructions provided by Lutron and the applicable provisions of the National Electrical Code and of the Safety Standards of Underwriter's Laboratories; (c) use of incompatible devices or accessories; (d) improper or insufficient ventilation; (e) unauthorized repairs or adjustments; (f) vandalism; (g) failure to comply with the Customer Obligations listed above; (h) an act of God, such as fire, lightning, flooding, tornado, earthquake, hurricane or other problems beyond Lutron's control; (i) moving the Supplied Computer to another geographic location; (j) a virus or computer hacker; or (k) failure to maintain equipment under specified ambient temperature.

2. On-site labor costs to diagnose issues with, and to remove, repair, replace, adjust, reinstall and/or reprogram the System or any of its components.
3. Components and equipment external to the System, such as, lamps; non-Lutron ballasts; OEM supplied Lutron ballasts, sockets, and fixtures; fixture wiring between ballasts and lamps; building wiring between the dimmer panels and lamps and between the controls and the control or dimmer panels; audio-visual equipment; and non-Lutron time clocks and motion detectors.
4. The cost of repairing or replacing other property that is damaged when the System does not work properly, even if the damage was caused by the System.
5. Any loss of software, including the Software, or data. Customer has sole responsibility to properly back up all data on the Supplied Computer's hard disk drive and on any other storage device(s) in the System.
6. Repairs required due to malfunctions caused by non-Lutron supplied software.

EXCEPT AS EXPRESSLY PROVIDED IN THIS WARRANTY, THERE ARE NO EXPRESS OR IMPLIED WARRANTIES OF ANY TYPE, INCLUDING ANY IMPLIED WARRANTIES OF FITNESS FOR A PARTICULAR PURPOSE OR MERCHANTABILITY.

<p>Job Name:</p> <p>Job Number:</p>	<p>Model Numbers:</p>
--	------------------------------

LUTRON DOES NOT WARRANT THAT THE SYSTEM WILL OPERATE WITHOUT INTERRUPTION OR BE ERROR FREE.

NO LUTRON AGENT, EMPLOYEE OR REPRESENTATIVE HAS ANY AUTHORITY TO BIND LUTRON TO ANY AFFIRMATION, REPRESENTATION OR WARRANTY CONCERNING THE SYSTEM.

UNLESS AN AFFIRMATION, REPRESENTATION OR WARRANTY MADE BY AN AGENT, EMPLOYEE OR REPRESENTATIVE IS SPECIFICALLY INCLUDED HEREIN, OR IN STANDARD PRINTED MATERIALS PROVIDED BY LUTRON, IT DOES NOT FORM A PART OF THE BASIS OF ANY BARGAIN BETWEEN LUTRON AND CUSTOMER AND WILL NOT IN ANY WAY BE ENFORCEABLE BY CUSTOMER.

IN NO EVENT WILL LUTRON OR ANY OTHER PARTY BE LIABLE FOR EXEMPLARY, CONSEQUENTIAL, INCIDENTAL OR SPECIAL DAMAGES (INCLUDING, BUT NOT LIMITED TO, DAMAGES FOR LOSS OF PROFITS, CONFIDENTIAL OR OTHER INFORMATION, OR PRIVACY; BUSINESS INTERRUPTION; PERSONAL INJURY; FAILURE TO MEET ANY DUTY, INCLUDING OF GOOD FAITH OR OF REASONABLE CARE; NEGLIGENCE, OR ANY OTHER PECUNIARY OR OTHER LOSS WHATSOEVER), NOR FOR ANY REPAIR WORK UNDERTAKEN WITHOUT LUTRON'S WRITTEN CONSENT ARISING OUT OF OR IN ANY WAY RELATED TO THE INSTALLATION, DEINSTALLATION, USE OF OR INABILITY TO USE THE SYSTEM OR OTHERWISE UNDER OR IN CONNECTION WITH ANY PROVISION OF THIS WARRANTY, OR ANY AGREEMENT INCORPORATING THIS WARRANTY, EVEN IN THE EVENT OF THE FAULT, TORT (INCLUDING NEGLIGENCE), STRICT LIABILITY, BREACH OF CONTRACT OR BREACH OF WARRANTY OF LUTRON OR ANY SUPPLIER, AND EVEN IF LUTRON OR ANY OTHER PARTY WAS ADVISED OF THE POSSIBILITY OF SUCH DAMAGES.

NOTWITHSTANDING ANY DAMAGES THAT CUSTOMER MIGHT INCUR FOR ANY REASON WHATSOEVER (INCLUDING, WITHOUT LIMITATION, ALL DIRECT DAMAGES AND ALL DAMAGES LISTED

ABOVE), THE ENTIRE LIABILITY OF LUTRON AND OF ALL OTHER PARTIES UNDER THIS WARRANTY ON ANY CLAIM FOR DAMAGES ARISING OUT OF OR IN CONNECTION WITH THE MANUFACTURE, SALE, INSTALLATION, DELIVERY, USE, REPAIR, OR REPLACEMENT OF THE SYSTEM, OR ANY AGREEMENT INCORPORATING THIS WARRANTY, AND CUSTOMER'S SOLE REMEDY FOR THE FOREGOING, WILL BE LIMITED TO THE AMOUNT PAID TO LUTRON BY CUSTOMER FOR THE SYSTEM. THE FOREGOING LIMITATIONS, EXCLUSIONS AND DISCLAIMERS WILL APPLY TO THE MAXIMUM EXTENT ALLOWED BY APPLICABLE LAW, EVEN IF ANY REMEDY FAILS ITS ESSENTIAL PURPOSE.

TO MAKE A WARRANTY CLAIM

To make a warranty claim, promptly notify Lutron within the warranty periods described above by calling the Lutron Technical Support Center at 1-800-523-9466. Lutron, in its sole discretion, will determine what action, if any, is required under this Warranty. Most System problems can be corrected over the phone through close cooperation between Customer and a technician. To better enable Lutron to address a warranty claim, have the System's serial and model numbers, its current operating system version, and the brand names and models of any peripheral devices (such as a modem) used with the System available when making the call. Let the technician know what error message you get; when it occurs; what you were doing when the error occurred; and what steps you have already taken to solve the problem. Listen carefully to the technician and follow the technician's directions.

If Lutron, in its sole discretion, determines that an on-site visit or other remedial action is necessary, Lutron may send a Lutron Services Co. representative or coordinate the dispatch of a representative from a Lutron approved vendor, to Customer's site, and/or coordinate a warranty service call between Customer and a Lutron approved vendor. All on-site labor costs incurred to diagnose any problems with

Job Name:	Model Numbers:
Job Number:	

the System and to repair, replace or adjust (at Lutron's option) the System to restore it to normal operation will be paid by customer at the then current service price unless covered by a Lutron Services Co. Support and Maintenance Plan.

REMOTE ACCESS

A dedicated analog phone line should be installed for the Supplied Computer to allow Lutron to remotely administer, troubleshoot, and support the System. Lutron does not recommended plugging the Supplied Computer into the analog phone line until

asked to do so by Lutron support personnel. During such support calls, Customer should disconnect the Supplied Computer from Customer's local LAN. Lutron expressly disclaims all liability due to local LAN problems or if the phone line is connected to the Supplied Computer at any other time. Customer retains all responsibility for ensuring the security of the Supplied Computer from unauthorized access.

For more information, including preventative maintenance steps, see the Users Guide provided by the Lutron approved vendor of, and included with, the Supplied Computer.

<p>Job Name:</p> <p>Job Number:</p>	<p>Model Numbers:</p>
--	-----------------------

1-Visit Start-up

Description

The 1-Visit Start-up package includes one on-site start-up visit and extends the limited warranty for your integrated lighting system.

Field Start-up – A Lutron Services Company Engineer will perform an on-site system inspection, start-up the system, and train facilities personnel on system operation and maintenance. This includes the cost of travel.

Visit Summary:

- Installation verification
- Wiring verification – power and low voltage
- Energizing the low voltage and enabling dimming for the system
- Verification of lighting loads
- System programming
- Training

Additional Information

Replaces the Standard Limited Warranty with the Lutron Electronics Co., Inc. Commercial Systems Limited Warranty. Also includes two consecutive 1-year Support and Maintenance Plans. Up to eight additional years of coverage can be purchased.

Extends limited warranty for Lutron ballasts from 3 years to 5 years, if start-up is purchased for the ballasts.

24-hour/7-days a week toll-free telephone support (1-800-523-9466).

Refer to the Lutron Electronics Co., Inc. Commercial Systems Limited Warranty pages for limitations, exclusions, and any other details pertaining to what is covered by this warranty.

Job Name: Job Number:	Model Numbers:
------------------------------	----------------

Support and Maintenance Plan - Silver Level (INIT) (LSC-SILV-CS-IN-1, LSC-SILV-CS-IN-2)

Description

- Includes 1-year Support and Maintenance Plan with system purchase and start-up, and commences on date of start-up completion.
- Covers on-site parts and labor, telephone technical support, and remote diagnostics
- Remote Access Support - Diagnostics and programming for systems with that capability (analog telephone line connection required, must be provided by system owner).
- 24-hour/7-days a week toll-free telephone support (1-800-523-9466).

Job Name: Job Number:	Model Numbers:
------------------------------	----------------

Terms and Conditions of Lutron Services Co., Inc. Support and Maintenance Plans

This Agreement between Lutron Services Co., Inc. ("LSC") and Customer provides parts and labor coverage for the Lutron Electronics Co., Inc. ("Lutron") Integrated Lighting Control System ("ILCS") purchased on this Bill of Material. Parts and labor are covered at 100%, as further specified below.

1. The Silver Plan COVERS:

- The diagnosis of problems with the Lutron ILCS and the repairs and adjustments necessary to restore the ILCS to normal operation are subject to the limitations described below. Visits will occur during normal business hours Monday through Friday.
- Replacement parts, new or rebuilt, at LSC's option.
- Four (4) hours of remote programming annually, for systems with that capability.
- Remote diagnostics, for systems with that capability.
- Unlimited Lutron Technical Support (1-800-523-9466).

2. Additionally, the Gold & Platinum Plans COVER:

- An annual ILCS Checkup which can include:
 - a) an evaluation to verify that the ILCS is working properly
 - b) verification that panels have not been overloaded in the course of building relamping or renovation
 - c) training of users on operation and maintenance of the ILCS
- For Trouble Calls, LSC will use commercially reasonable efforts to be at the Customer's site within 24 hours (for Platinum customers) or 72 hours (for Gold customers) of receipt of the request.

3. Service Procedures

- To schedule a visit, call 610-282-3800 and request to be connected to Field Service Scheduling.
- LSC representatives will perform service in compliance with security and other instructions provided by the Customer.
- LSC will respect the Customer's need for confidentiality and will utilize job-specific information only as needed to complete the service visit.
- ILCS Checkups (for Gold and Platinum customers) will occur during normal business hours Monday through Friday. They must be scheduled at least two weeks in advance.
- Customer agrees to allow LSC prompt and sufficient access to Customer's facility and to provide reasonable information and assistance to the LSC representatives to expedite the performance of service.
- Customer agrees that all LSC service must be done in compliance with LSC's safety procedures, which may include temporarily disabling or de-energizing the ILCS and other equipment connected to the ILCS.
- LSC will provide a certificate of insurance upon request of Customer.

4. This plan DOES NOT COVER:

- Damage or malfunctions diagnosed by LSC as due to abuse, misuse, or accident, such as: use of incorrect line voltage, fuses or protection devices; failure to follow operating and maintenance instructions provided by Lutron or LSC; failure to comply with national or local electrical codes; unauthorized repairs/adjustments; vandalism or theft; fire, flood, "Acts of God", or other problems beyond LSC's control.
- Non-Lutron components and equipment such as: lamps; non-Lutron ballasts, sockets, and fixtures; fixture wiring between ballasts and lamps; building wiring between ILCS elements; audio-visual

Job Name:	Model Numbers:
Job Number:	

equipment; non-Lutron timeclocks and motion detectors; and Local Area Networks.

- Labor costs to remove and reinstall fixtures and/ or ballasts.
- Desktop, Laptop, or Server hardware and software.
- Repairs or adjustments to Lutron ILCS required as a result of (i) malfunctions caused by non-Lutron supplied equipment, (ii) software that is connected to or used with the ILCS, or (iii) programming changes made by anyone other than LSC.

5. Warranties

- LSC makes no warranty, either express or implied, including, but not limited to, any implied warranties of merchantability and fitness for a particular purpose
- For ILCS components that may be covered by product-specific warranties, LSC will coordinate the processing of any warranty claims.

6. Limitation of Remedy

- CUSTOMER'S EXCLUSIVE REMEDY AND LSC'S ENTIRE, COLLECTIVE LIABILITY IN CONTRACT, TORT OR OTHERWISE, UNDER THIS AGREEMENT IS THE REPAIR OF THE DEFECTIVE ILCS IN ACCORDANCE WITH THIS AGREEMENT. IF LSC IS UNABLE TO MAKE SUCH REPAIR, CUSTOMER'S EXCLUSIVE REMEDY AND LSC'S ENTIRE LIABILITY WILL BE THE PAYMENT OF ACTUAL DAMAGES NOT TO EXCEED THE CHARGE PAID BY CUSTOMER FOR ONE YEAR OF SERVICE UNDER THIS AGREEMENT. UNDER NO CIRCUMSTANCES WILL LSC BE LIABLE TO CUSTOMER OR ANY OTHER PERSON FOR ANY DAMAGES, INCLUDING, WITHOUT LIMITATION, ANY INDIRECT, INCIDENTAL, SPECIAL, OR CONSEQUENTIAL DAMAGES, EXPENSES, COSTS, PROFITS, LOST SAVINGS OR EARNINGS, LOST OR CORRUPTED DATA, OR OTHER LIABILITY ARISING OUT OF OR RELATED TO THIS AGREEMENT, OR OUT OF THE INSTALLATION, DEINSTALLATION, USE OF OR INABILITY TO USE THE SYSTEM.

- THIS AGREEMENT GIVES CUSTOMER SPECIFIC LEGAL RIGHTS AND CUSTOMER MAY HAVE OTHER RIGHTS THAT VARY FROM STATE TO STATE. SOME STATES DO NOT ALLOW THE EXCLUSION OR LIMITATION OF (i) INCIDENTAL OR CONSEQUENTIAL DAMAGES OR (ii) IMPLIED WARRANTIES, SO THE ABOVE MAY NOT APPLY.
- Customer shall not bring legal action related to the services being provided hereunder more than two years after the cause of action arose unless otherwise provided by local law without the possibility of contractual waiver or limitation.
- LSC shall not be responsible for any delay or failure to perform its responsibilities under this Agreement that results from problems outside the control of LSC such as: permit or visa requirements; strikes or work stoppage; fires, floods, "Acts of God", wars, or force majeure; and transportation disruptions.
- With regard to any services that are not within the coverage of this Agreement, please contact LSC for service pricing and availability.

7. Taxes

- Customer agrees to pay all taxes (or reimburse LSC for all amounts paid or payable by LSC in discharge of these taxes) arising from this Agreement including state and local sales and use taxes, regardless of designation.

8. Term; Termination

- The term of this Agreement shall commence on the date of start-up completion and shall continue for the number of one-year terms purchased on the Bill of Material.
- Default: LSC may terminate this Agreement if Customer remains in default of any material term or condition of this Agreement ten days after LSC gives Customer written notice of the default.
- Unnecessary Service Calls: If Customer requests service on more than two (2) occasions in any one year for problems that are diagnosed by LSC as non-covered problems, LSC may terminate this Agreement by providing Customer with 30 days notice of termination.

<p>Job Name:</p> <p>Job Number:</p>	<p>Model Numbers:</p>
--	------------------------------

9. Miscellaneous

- **Entire Agreement:** This Agreement is the complete agreement between Customer and LSC regarding the services provided hereunder, and replaces any prior oral or written communications between Customer and LSC regarding such services. None of LSC’s employees or agents may orally vary the terms and conditions of this Agreement. Any modification of this Agreement must be signed in writing by authorized representatives of Customer and LSC.
- **Additional Remedies:** This Agreement affords Customer specific legal rights. Customer may have additional legal rights that vary from state to state. This Agreement is not a warranty. The ILCS may come with a limited warranty from Lutron or third party manufacturers of products distributed by Lutron. Please consult those warranties for specific rights and remedies.

- **Severability:** If any part of this Agreement is held to be invalid or unenforceable, it will not affect the validity or enforceability of the rest of the Agreement. Without further action of the parties, that part will be reformed to the minimum extent necessary to make it valid and enforceable.
- **Waiver of Rights:** LSC’s failure to exercise, delay in exercising, or single or partial exercise of any right, power, or privilege under this Agreement shall not operate to waive or preclude LSC’s right to exercise such rights, power, or privileges.
- **Send Notices to:** Lutron Services Co., Inc., Attn: Director of Field Service, 7200 Suter Road, Coopersburg, PA 18036, cc: Legal Dept.

<p>Job Name:</p> <p>Job Number:</p>	<p>Model Numbers:</p>
--	------------------------------

Lutron Contacts for all Warranties and Support and Maintenance Plans

Internet: www.lutron.com
E-mail: lscwarranty@lutron.com

WORLD HEADQUARTERS

USA

Lutron Electronics Co., Inc.
7200 Suter Road, Coopersburg, PA 18036-1299
TEL +1.610.282.3800
FAX +1.610.282.1243
Toll-Free 1.888.LUTRON1
Technical Support 1.800.523.9466

North and South America Technical Hotlines
USA, Canada, Caribbean: 1.800.523.9466
Mexico: +1.888.235.2910
Central/South America: +1.610.282.6701

EUROPEAN HEADQUARTERS

United Kingdom

Lutron EA Ltd.
6 Sovereign Close, London,
E1W 3JF United Kingdom
TEL +44.(0)20.7702.0657
FAX +44.(0)20.7480.6899
FREEPHONE (UK) 0800.282.107
Technical support +44.(0)20.7680.4481

ASIAN HEADQUARTERS

Singapore

Lutron GL Ltd.
15 Hoe Chiang Road,
#07-03 Euro Asia Centre,
Singapore 089316
TEL +65.6220.4666
FAX +65.6220.4333

Asia Technical Hotlines

Northern China: 10.800.712.1536
Southern China: 10.800.120.1536
Hong Kong: 800.901.849
Indonesia: 001.803.011.3994
Japan: +81.3.5575.8411
Macau: 0800.401
Singapore: 800.120.4491
Taiwan: 00.801.137.737
Thailand: 001.800.120.665853
Other countries: +65.6220.4666

Job Name:	Model Numbers:
Job Number:	

GRAFIK 3000/4000/QSG System On-Site System Start-up

What Standard GRAFIK 3000/4000 Start-up includes:

- One visit to the job site during normal business hours. This is one visit between the hours of 7 AM and 5 PM on a Monday through Friday that is not a Lutron Holiday.
- This visit may require multiple days depending on the size of the system.
- Phased construction projects (requiring multiple visits) should verify this was included with the system provider.
- Visits can be made outside these hours for an additional charge.
- Lutron requires Ten (10) business days notice to schedule a start-up date. Shorter notices may incur expedite fees.
- All terminations will be done by the installing agency. A person from the installing agency needs to be present for the startup. This person should be familiar with the installation of the system.
- A Lutron factory certified technician performs all system start-up items.

System start up includes:

- Verification that the system is installed according to Lutron specifications.
- Panels should be energized in by-pass fully lamped and tested prior to our arrival.
- Load circuits are checked for shorts and overloads and bypass jumpers are removed.
- Programming the dimming/switching panels to include:
 - Panel addressing
 - Proper load types as installed in field or as per approved submittal drawings. As installed conditions take precedence. This system may have modular components and if loads differ from design additional/different equipment may be required.
 - Circuit to zone assignment as per approved submittal drawings. If no zoning information exists prior to start-up, programming will be done according to written instructions from end user or end users representative, contractor, or will be set up based on the field engineers past experience in that order of priority.
 - Set light levels and fade times on controls as per approved submittal drawings. If no information is provided, test scenes will be set to 100%, 75%, 50% and 25% and default fade times will be set to 3 seconds.
 - Program emergency function per the installation guide for the system. This may not be applicable for every system.

Programming the wall controls/interfaces to include:

- Control addressing
- Verify proper wiring and operation of control link
- Set up controls to function as per approved submittal drawings. If no control functionality is included, controls will be programmed according to written instructions from end user or end users representative, contractor, or will be set up based on the field engineers past experience in that order of priority.
- Test all buttons to assure proper operation
- Occupancy sensor
 - Verification of proper installation and operation.
 - Unless otherwise noted, a rough calibration will be performed at system start-up. Final calibration is the responsibility of the end user since it is very dependent on furniture placement, HVAC operation, and space usage.

Job Name:

Toll Free 24/7 Tech Support Line 1.800.523.9466

Job Number:

Field Service Scheduling 1.800.523.9466 ext. 4439

- Photocell
 - Verification of proper installation and operation.
 - Unless otherwise noted a rough calibration will be performed at system start-up. Final calibration is the responsibility of the end user since it is very dependent on furniture placement, window treatments, outside weather conditions and space usage.
- Time clock set up
 - Lutron will set up the system location, daylight savings, and time of day preparation for event programming.
 - Lutron will set up time clock events as per the approved submittal drawings or written instructions from end user or end users representative, contractor in that order of priority.
 - In lieu of instructions, the time clock will not be programmed.

Items not included in standard on-site startup:

- Lutron service technicians will not perform work on non-Lutron equipment. Lutron will work with other manufacturers on integration of equipment by others.
- Programming or any other changes that are requested to be performed counter to the approved submittal drawings must be approved in writing via the proper channels.
- Field wiring changes or corrections that delay the startup process such that additional time is required for Lutron to complete the startup in the allotted time will result in additional charges.
- Replacement of controls damaged due to miss-wires or incorrect installation or any other related issue not covered under the Lutron warranty is the responsibility of the installer.
- Reprogramming of any functions after initial programming and sign-off.

End user training on overall system operation. Typical training agenda listed below:

- This system is not typically sold with a separate visit for the training of the end user. Check with purchasing agent if this is required.
- It is the responsibility of the person scheduling the startup to ensure the appropriate end users are present for system training. Lutron typically does not have these contacts.
- Additional charges will apply if a separate visit is required for training the end user.
- Video media is not provided by Lutron for training sessions. This may be provided by “others” for turnover to the end user or job site documentation.
- System demonstration and sign-off by the end user.

Additional items that are not included with standard startup, but may be purchased – check your quote to verify an item has been included with your quote. The quantity of the items listed below on the BOM will determine how many days are included with this item.

- LSC-AF-VISIT. Aim and focus visit with design team or end user. This visit is typically coordinated by the construction team, that includes designers, Lutron, and end user to set up light levels and adjust fixtures.
- LSC-SYSOPT. System optimization visit with end user. This visit is coordinated by the EC or end user to optimize the system performance to specific project details.
- LSC-WALK. Start-up agent or design team walk-through visit. The construction team and the agent requiring the walk-through coordinate this visit. This visit is for any type of additional walk-through that is required for job completion.

Job Name:

Toll Free 24/7 Tech Support Line 1.800.523.9466

Job Number:

Field Service Scheduling 1.800.523.9466 ext. 4439

- LSC-SILV/GOLD/PLAT-IW. These are extended warranty part numbers for the system per the specification. Warranty information is supplied within the submittal documentation.
- LSC-TRAINING. This visit is for additional time on the job for training the end user. The EC or the end user typically coordinates this visit.
- LSC-AH-SU. After hours start-up. If normal business hours are not acceptable for start-up, after hours start-up can be purchased.

Additional items listed below may be charged for jobsites that are scheduled for start-up, but not ready when field service engineer arrives.

- LSC-NS-TRAVEL. Non standard travel arrangements
- LSC-SITE-RDY-CHG. Site ready charge. Jobsite not ready.

Job Name:

Toll Free 24/7 Tech Support Line 1.800.523.9466

Job Number:

Field Service Scheduling 1.800.523.9466 ext. 4439

GRAFIK Eye Family 3000/4000/QSG Series

GRAFIK Eye 4000 Family Series is an architectural preset lighting control product that creates functional spaces through various lighting combinations. It utilizes low voltage digital controls that communicate with high voltage dimming and switching panels. The digital nature of the product allows the user to quickly and easily select lighting scenes to align with the use of the space. These scenes can be reprogrammed as the needs of the space change.

GRAFIK Eye 3000 Family Series is an architectural preset lighting control product that creates functional spaces through various lighting combinations. It utilizes low voltage digital controls that communicate with high voltage digital controls. The digital nature of the product allows the user to quickly and easily select lighting scenes to align with the use of the space. These scenes can be reprogrammed as the needs of the space change.

4000 Training Visit – Typical Agenda (duration – approximately 1 hour):

- Review system with end-user (control location and function).
- Discuss system model numbers
- Discuss Lutron lexicon – what is a zone, scene, fade rate
- Review GRAFIK EYE main controller functions
 - How to set a scene
 - How to adjust fade rate
 - How to make a temporary scene
 - How to set light loads
 - How to change light levels
- Special save modes and when to use each
- Review all accessory controls functions
 - How to address accessory controls
 - Programming scenes from accessory controls
- Review dimmer panel(s) (for G4000 system, N/A for G3000 systems)
 - Bypassing a G4000
 - Spare dimmer cards
- Load schedule
- Troubleshooting the system
- Preventive maintenance
- Liaison software (if applicable)
- Timeclock options
 - Real Time
 - Astronomic

NOTE: All topics may not be relevant to every system

Job Name:

Toll Free 24/7 Tech Support Line 1.800.523.9466

Job Number:

Field Service Scheduling 1.800.523.9466 ext. 4439



service and support guide | lighting control system

service record

This information will help us assist you when you contact Lutron:

Job Number (typically on the front cover of the panels)

Approximate date of initial installation

Job Name at time of installation

This pocket is provided for storage of service visit sign-off sheets and other important system documentation.

Lutron controls the light at the following locations featured in this brochure:

- Cover:** Lutron Electronics Headquarters, Coopersburg, Pennsylvania, U.S.A.
Page 1: New York Times Building, New York, New York, U.S.A.
Page 2: Bank of China Headquarters, Beijing, China
Pages 4–5: Getty Museum, Los Angeles, California, U.S.A.
JW Marriott Hotel Shanghai at Tomorrow Square, Shanghai, China
Mandarin Oriental, Tokyo, Japan
Louis Vuitton, Cannes, France
Orange County Convention Center, Orlando, Florida, U.S.A.
Page 7: Mandarin Oriental, New York, New York, U.S.A.
Page 8: TAQA, Ann Arbor, Michigan, U.S.A.
Page 10: The Westbury Mayfair Hotel, London, UK
Page 11: Wynn Las Vegas, Las Vegas, Nevada, U.S.A.
Mandarin Oriental, New York, New York, U.S.A.
Georgian College, Ontario, Canada

Lutron, the sunburst logo, EcoSystem, GRAFIK Eye, GRAFIK 6000, and seeTouch are registered trademarks of Lutron Electronics Co., Inc. GRAFIK Eye 3000, GRAFIK Eye 4000, GRAFIK 5000, GRAFIK 7000, Quantum, and GRAFIK Eye QS are trademarks of Lutron Electronics Co., Inc.

Thank you for purchasing a Lutron lighting control system.

This guide contains the information you will need to ensure your ownership experience is a good one. Please retain it for future reference. It contains important information on warranties, service, upgrades and more.

- 02** | who to call if you have problems
- 03** | what to do if your system needs service
- 04** | replacement parts
- 04** | spare parts packages
- 05** | training sessions
- 05** | optimize energy usage
- 06** | support & maintenance plans
- 07** | annual scheduled maintenance visits
- 08** | new and improved Lutron products
- 11** | modernize your lighting control system
- 11** | system expansions
- 12** | Lutron in your home



who to call if you have problems: 1.800.523.9466

24-hour Technical Support at No Charge

If you have questions about the operation of your system, or if you are not sure it is functioning properly, Lutron provides around-the-clock technical support. A knowledgeable support staff is ready to answer questions about the operation, programming, and maintenance of your system. They can also direct you to the technical information on our website that is specific to your Lutron products.

From the U.S., call 1.800.523.9466. International customers can dial 1.610.282.3800 or visit www.lutron.com to get more information on our international offices.

Where to Find Your Lutron Job Number

You can find this number on the cover of any dimming panel. This number could be formatted in one of several ways. It will typically look like one of the following:

012-####

014-####

#####

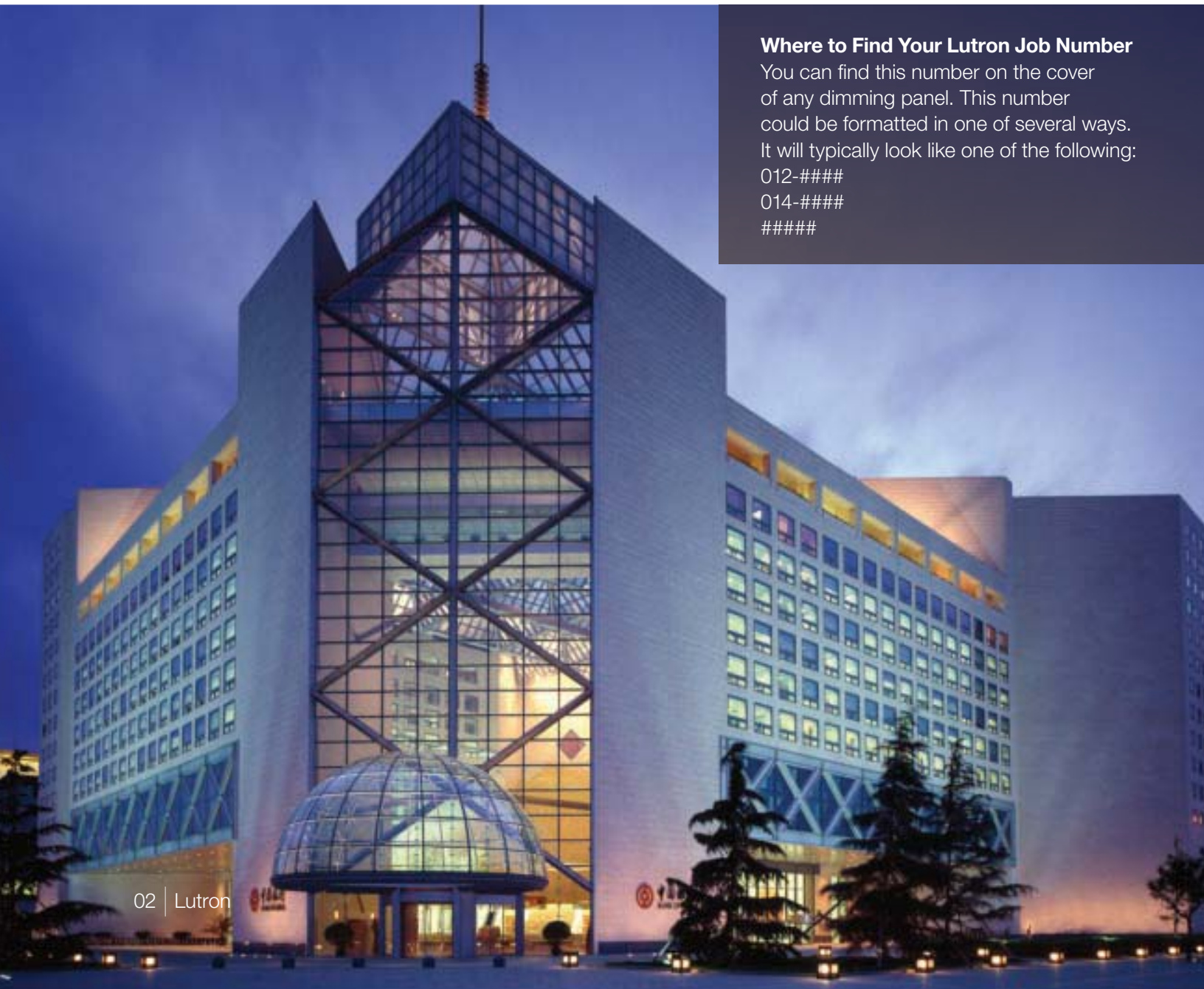

what to do if your system needs service

If your staff is unable to solve a problem with the help of our Technical Support Representatives, do not worry. There are other ways to get your system up and running. Lutron also provides reprogramming and training services. Please read over the points listed below to ensure you get the best service for your situation.

*Lutron Scheduling Representatives:
1.800.523.9466 and select
option 4, then 1 or email
LSCscheduling@lutron.com.*

- Determine your system coverage (see below).
- If you do not have a Support & Maintenance Plan or labor coverage, we recommend working with a local electrical contractor.
- If the electrical contractor was unable to solve the problem for you, please contact our Scheduling Representatives to set-up a Lutron field service visit.

How to Determine Your System Coverage

Lutron systems that are purchased with start-up have an initial 2-year Support & Maintenance Plan and an 8-year Limited Parts Warranty. That initial plan provides full labor and parts coverage for two years for the majority of equipment. Details on labor and parts coverage can be found in the below charts. The documents from the installing contractor will indicate what coverage you have for your particular system. *If you are unable to find that information, call 1.800.523.9466 and select option 4, then 4 or email LSCwarranty@lutron.com.*

With Lutron Start-up

System Component	Part Coverage	Labor Coverage
Lighting Control Equipment (excluding parts listed below)	100%, first 2 years 50%, year 3 through 5 25%, year 6 through 8	100%, 2 years
Ballasts	100%, 5 years	None
Computer/Laptop/PDA	100%, 1 year	100%, 1 year

To supplement or extend the initial coverage that comes with Lutron start-up, we offer Support & Maintenance Plans that provide up to 10 years of full labor and parts coverage (see pages 6 and 7 for more information).

Without Lutron Start-up

System Component	Part Coverage	Labor Coverage
Lighting Control Equipment (excluding parts listed below)	100%, 1 year	None
Ballasts	100%, 3 years	None
Computer/Laptop/PDA	100%, 1 year	None

replacement parts

If you are experiencing a problem with your system and need to order replacement parts, you can call one of our Parts Specialists. If possible, please have the part number of the failed item as well as the Lutron Job Number for your system. In many cases, we will have the parts in stock and will send them to you in as little as two days.

For custom products and older generation systems, it may take longer for us to provide replacement parts. In those cases, the components that we need to make the products may no longer be available from our suppliers. As a result, we may ask you to send the failed part back to us so we can try to repair it rather than replace it.

To request more information, please call 1.800.523.9466 and select option 4, then 2 or email LSCparts@lutron.com.



spare parts packages

Having a stock of parts at your facility can ensure that small problems will be resolved rapidly. Some components can be installed in minutes, and Lutron's 24-hour Technical Support Representatives are available to walk your maintenance team or local contractor through the process.

We can prepare a recommended spare parts list based upon the specific configuration of your system and any unique requirements you have.

To request more information, please call 1.800.523.9466 and select option 4, then 2 or email LSCparts@lutron.com.

training sessions

On Our Site: The software used with our GRAFIK™ 5000/6000/7000 and Quantum™ systems allows a facility manager to reprogram, control, and monitor the lighting control system. To maximize the benefits this software provides, Lutron offers Facility Manager Training at our headquarters in Coopersburg, PA. The cost of these classes is minimal, and the feedback from past attendees has indicated that the training is well worth the time investment.

Go to www.lutron.com/training to see course dates and registration details.

On Your Site: If staff turnover has left you without anyone who knows how to operate and maintain your system, you can purchase a day of personalized training. This could be an ideal time to make any timeclock or wall control programming changes.

System specific training agendas are available on our website at www.lutron.com/service.



optimize energy usage

Although your lights turn on and off, there are many features that go beyond those basic options. Lighting strategies that take advantage of those new features can lead to more productive environments, happier occupants, and reduced lighting electricity bills.



Studies show that office buildings expend 44% of electricity on lighting alone. You can reduce your lighting energy consumption with a Lutron System Optimization Visit. This type of visit will help you implement strategies that will result in better system performance and more efficient energy usage.

To request more information, please call 1.800.523.9466 and select option 4, then 5 or email rus@lutron.com.

support & maintenance plans

The initial 2-year Silver Support & Maintenance Plan included with most systems can be extended for up to 10 years to ensure the lighting system will continue to satisfy the needs of the facility. With a Support & Maintenance Plan in place, a repair visit is just a phone call away. Annual payments are typical, but quarterly or monthly payments can be arranged to accommodate your budgeting needs.

The table below highlights the features of our three standard plans. If these plans do not fit your needs, please contact us and we can create a custom plan just for your facility.

	benefits	typical applications
 platinum	<ul style="list-style-type: none">• 24-hour response time for service visits• Annual Scheduled Maintenance Visit (see page 7 for details)• 100% parts, 100% labor and any travel costs Lutron incurs• Technical Support, toll-free, around the clock, 365 days per year• Remote diagnostics and programming (for systems with that configuration/capability)	<ul style="list-style-type: none">• Casinos• Convention centers• Luxury hotels/Resorts• Research centers/Vivariums• Hospitals
 gold	<ul style="list-style-type: none">• 72-hour response time for service visits• Annual Scheduled Maintenance Visit (see page 7 for details)• 100% parts, 100% labor and any travel costs Lutron incurs• Technical Support, toll-free, around the clock, 365 days per year• Remote diagnostics and programming (for systems with that configuration/capability)	<ul style="list-style-type: none">• Hotels• Stadiums/Arenas• Museums• Office buildings• High-end restaurants• Boutique retail• Large universities• Estates
 silver	<ul style="list-style-type: none">• 100% parts, 100% labor and any travel costs Lutron incurs• Technical Support, toll-free, around the clock, 365 days per year• Remote diagnostics and programming (for systems with that configuration/capability)	<ul style="list-style-type: none">• Places of worship• Residences• Libraries• Small offices• Small schools

annual scheduled maintenance visits

Our Gold and Platinum Support & Maintenance Plan customers automatically receive an Annual Scheduled Maintenance Visit, but any customer can purchase a day of this service. According to each site's requests and needs, the Lutron Field Service Engineer may complete the following tasks during this visit:

- Train facility staff
- Update staff on new features and capabilities
- Make minor programming changes
- Perform a system check and preventative maintenance
- Provide a system status report
- Compile a list of spare parts to consider for site



new and improved Lutron products

Add Engraving to Existing Controls

With proper labeling of the buttons on existing controls, your lighting system will be easier to use for you and anyone that enters the space. Nearly all Lutron wall controls can be engraved with labels for individual buttons or the entire control. Most engravings are custom to the project but standard options are also available. Engravings are available in a variety of colors and we can laser engrave in any language.

Engraving sheets are available at www.lutron.com/seeTouch.



Upgrade to seeTouch®

An engraved control is better than one that is not, but a control with engraving that can be read in the dark is the ultimate solution. Controls in Lutron's GRAFIK™ 3000/4000/5000/6000/7000 lighting control systems can be replaced to feature this intuitive and ergonomic wall control option.

To upgrade your controls, please call 1.800.523.9466 and select option 4, then 5, or email rus@lutron.com.



seeTouch®

Discover the intuitive simplicity of Lutron's seeTouch controls. As you can see above, our wall controls have continued to evolve into more beautiful and user-friendly additions to your facility. Engraved buttons make them easy to use for newcomers to the space and the backlit buttons remove the need to search for wall controls in the dark.

For more information, please visit www.lutron.com/seeTouch.

Upgrade to GRAFIK Eye® QS

With the positive feedback from the experience our customers had with seeTouch controls, we updated our GRAFIK Eye product to include some of the same engraving and backlit features. An added bonus to the GRAFIK Eye QS is the opportunity to conveniently control shades and lighting from one control station.

To upgrade your controls, please call 1.800.523.9466 and select option 4, then 5, or email rus@lutron.com.

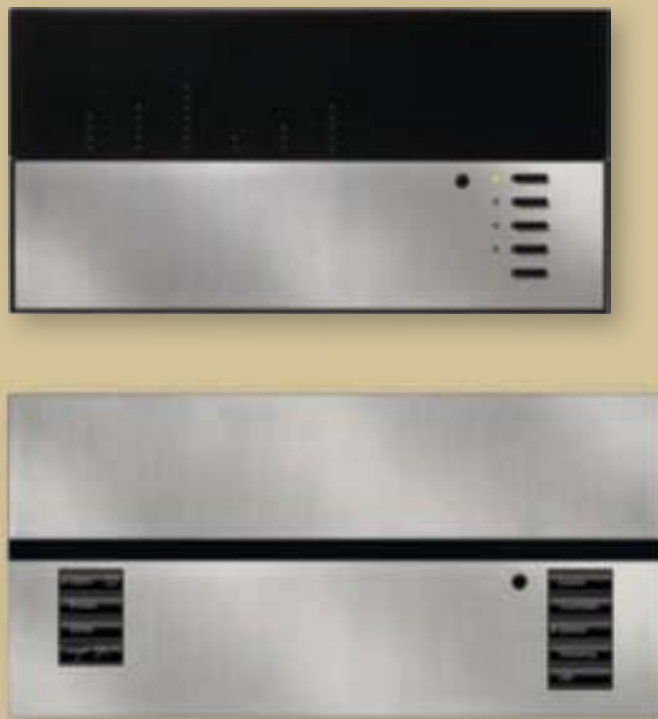

GRAFIK Eye® QS

Set your lights and shades just right for any task or activity in any room of your building. Easily recall these settings with the touch of a button. The new GRAFIK Eye QS provides convenient control and enhancement of the visual environment for the people inside the space.

For more information, please visit www.lutron.com/GRAFIKEyeQS.



modernize your lighting control system

You originally purchased a Lutron lighting control system because you wanted the ultimate in reliability and performance. The pace of innovation in Lutron's products has been rapid—the systems of today have features that were beyond reach just five years ago. These features may be just what you are looking for as you modernize your facilities.

In addition to improved serviceability, a new system brings advanced control features and energy saving capabilities that will take your lighting control experience to the next level.

Regardless of your reasons for wanting to upgrade or replace your system, Lutron will integrate the best products and services to give you a solution that meets your needs.

For more information on upgrading your system, please call 1.800.523.9466 and select option 4, then 5 or email rus@lutron.com.



system expansions

If you are expanding your building, or if existing areas of the building need to be incorporated into the system, we can provide a solution. Our systems are modular and expandable, allowing you to add capabilities or capacity as required.

Adding photo or occupancy sensors can help save energy. Using Lutron occupancy sensors can eliminate 20–30% of lighting energy costs.

Our Replacement Systems Specialists can review the equipment you have, work with you to determine what capabilities and features you want, and propose comprehensive solutions for your lighting needs.

For more information, please call 1.800.523.9466 and select option 4, then 5 or email rus@lutron.com.



Lutron in your home

When it comes to controlling electric and natural light, Lutron has the best products for any application, including your home.

The same world-class quality and engineering in the lighting controls in Buckingham Palace and the White House can be found in the dimmer that you can purchase for your home. After all, we feel that everyone deserves the benefits of dimming such as increased bulb life, improved energy savings, and enhanced room settings.

For assistance in locating Lutron products for your home, go to www.lutron.com.

Save energy beautifully

dimming the lights about	saves electricity	extends bulb life*
10%	10%	2 times longer
25%	20%	4 times longer
50%	40%	20 times longer
75%	60%	20 times longer +

* incandescent and halogen

www.lutron.com

save
energy
with
Lutron™ 

 **LUTRON**® SERVICES CO., INC.

www.lutron.com/service

Lutron Services Co., Inc.
7200 Suter Road
Coopersburg, PA 18036-1299

World Headquarters 1.610.282.3800
Technical Support Center 1.800.523.9466

© 02/2009 Lutron Services Co., Inc. | P/N 367-341 Rev. C
Made and printed in the U.S.A.



Install & Setup Guides

Job Name:

Toll-Free 24/7 Technical Support Line: 1.800.523.9466

Job Number:

Field Service Scheduling 1.800.523.9466 ext.4439



GRAFIK Eye® QS System

Please Read

Installation and Operation Guide

The GRAFIK Eye QS System allows for control of both lights and shades or window treatments using a single control unit. Features include pushbutton scene recall, info screen that displays energy savings and status, IR receiver, astronomic timeclock, occupant sensor connection, and backlit buttons that are easy to find and operate.

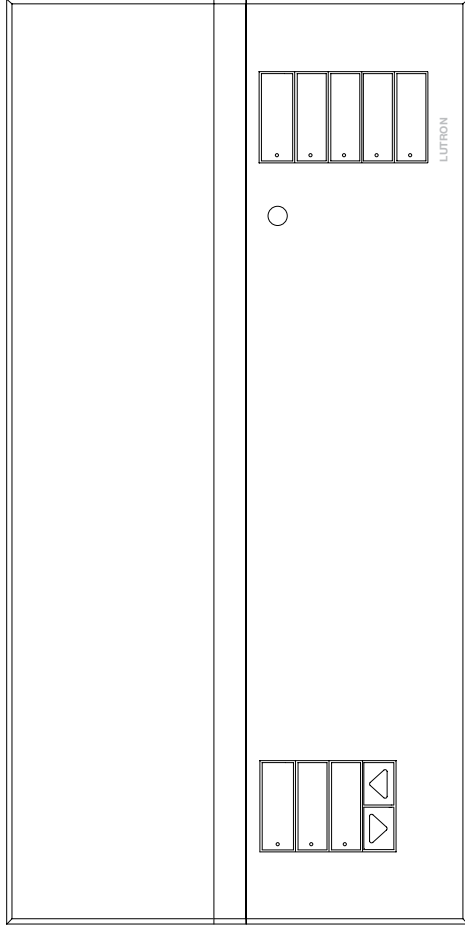

Model Number	Unit Capacity (watts)	Zone Capacity (watts)	Unit Dissipation (BTUs/hour)
QSG - 3P120	2000	800	61.5
QSG - 4P120	2000	800	61.5
QSG - 6P120	2000	800	61.5

(see page 8 for additional ratings)

All units: 120 V ~ 50/60 Hz

Contents

Installation

- Features and Functions of the GRAFIK Eye QS System 2
- Wiring the GRAFIK Eye QS System 3
- Wiring the GRAFIK Eye QS System
 - PELV (Class 2: USA) Cable 4
 - QS System Low-Voltage Control Wiring 5
 - QS System Low-Voltage Terminal Connections 6
- Installing the GRAFIK Eye QS System 7
- Zone Setup 8

Operation

- Preprogrammed Button Functionality 10
- General Functionality 11
- General Functionality: Programming Mode 12
- Zone Button Operation 13
- Quick Scene Programming 15
- Scene Setup 16
- LED Displays for Lighting Levels 18
- Adjusting Window Treatment Settings 19
- Timeclock Operation 23
- Set Save Mode 28
- Set Up Occupant Sensor 29
- Activate System Accessories 30
- Faceplate Removal 30
- Troubleshooting 31
- Menu Options 34
- Warranty 35
- Contact Information 36

Features and Functions of the GRAFIK Eye® QS System

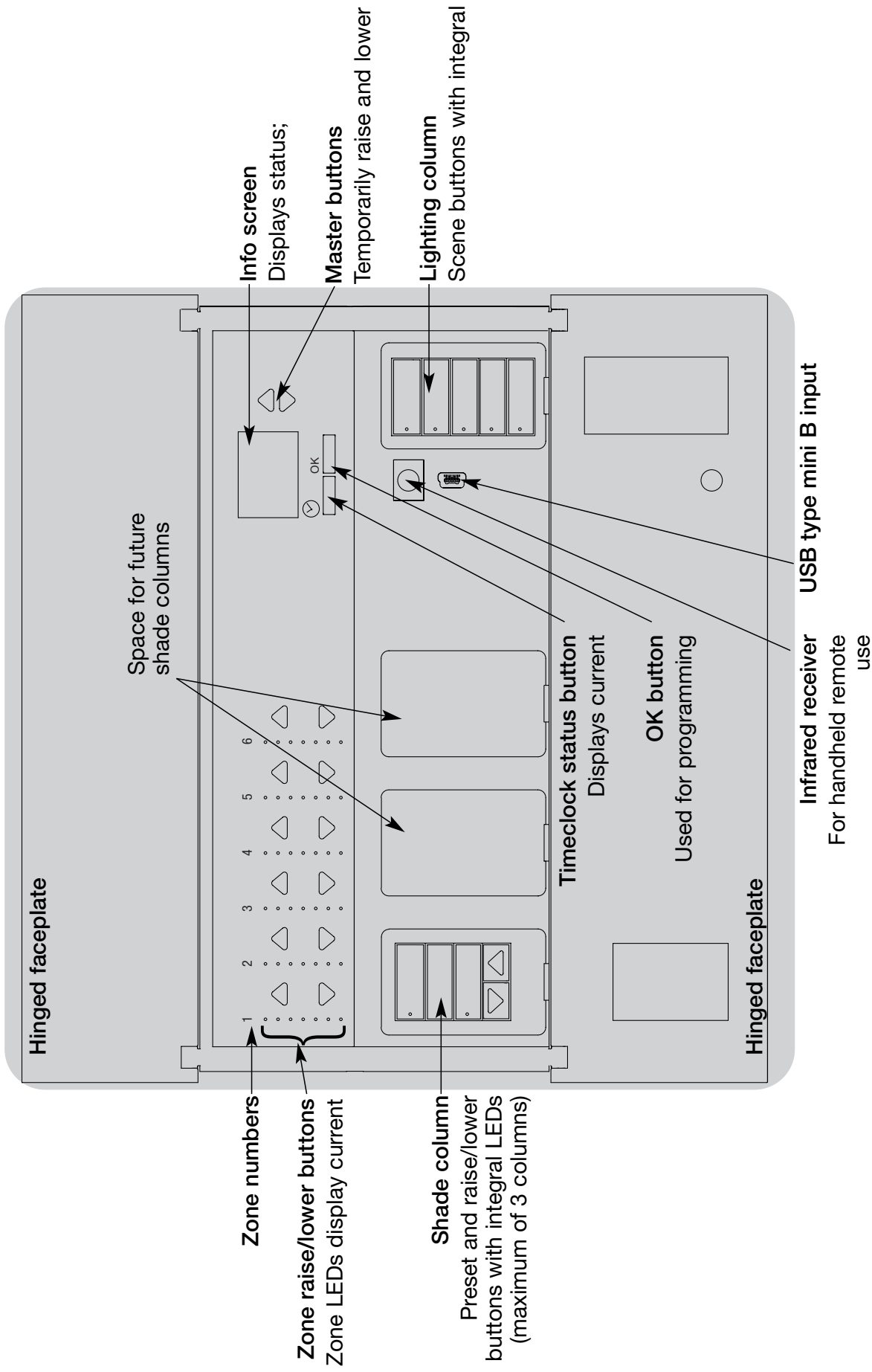

Wiring the GRAFIK Eye® QS System

Important Wiring Information

- Use properly certified cable for all line voltage/mains cables.
- Proper short-circuit and overload protection must be provided at the distribution panel. You can use up to a 20 A maximum circuit breaker/MCB for your installation.
- Install in accordance with all local and national electrical codes.
- PELV (Class 2: USA) terminals may be unplugged for ease of IR, occupant sensor, and control wiring.



Caution! Before connecting the loads to the control unit, test the loads for short-circuits.

1. Turn power OFF at the circuit breaker or fuse box.
2. Connect a standard light switch between the live lead and load wire to test the circuit.
3. Turn power ON and check for short or open circuits. If load does not operate, the circuit is open. If the breaker/MCB trips (fuse blows or opens), a load short may exist. Correct short or open circuits and test again.

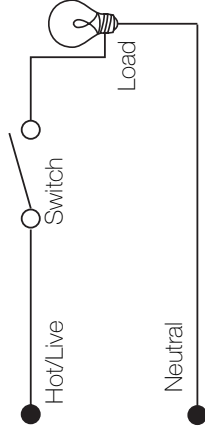

Danger! GRAFIK Eye QS control units must be installed by a qualified electrician in accordance with all applicable regulations and building codes. Improper wiring can result in personal injury or damage to control units or other equipment. Always turn off circuit breaker or remove main fuse from power line before doing any work. To avoid overheating and possible damage to equipment, do not install dimming devices to dim receptacles, motor-operated appliances, or fluorescent lighting not equipped with Lutron Hi-lume®, Eco-10™, or Tu-Wire® electronic dimming ballasts, or devices approved for your location. In dimmed magnetic low-voltage circuits, you can prevent transformer overheating and failure by avoiding excessively high current flow: Do not operate control units with any lamps removed or burned out; replace any burned out lamps immediately; use only transformers that incorporate thermal protection or fused primary windings. Control units are designed for residential and commercial use, for indoor use only.



Caution! Do not connect line voltage/mains cable to PELV (Class 2: USA) terminals.

- Earth/ground terminal connection must be made as shown in wiring diagrams.
- Do not mix different load types on the same zone.
- Follow all local and national electrical codes when installing PELV (Class 2: USA) wiring with line voltage/mains wiring.
- Test for short-circuits on loads before wiring QS control unit.

To connect the line voltage/mains cables to the control unit:

1. Strip 5/16 in. (8 mm) of insulation off the line voltage/mains cables in the wallbox.

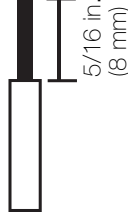

2. Connect the line voltage/mains, ground, and load wires to the appropriate terminals on the back of the control unit. The recommended installation torque is 5.0 in.-lbs. (0.6 N•m) for line voltage/mains connections and 5.0 in.-lbs. (0.6 N•m) for the earth/ground connection.

Wiring the GRAFIK Eye® QS System PELV (Class 2: USA) Cable

IR Wiring

#18 AWG (1.0 mm²)

each terminal

From external

IR connection

(by others)

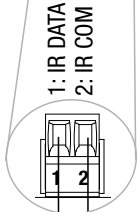

Occupant Sensor Wiring

#18 AWG (1.0 mm²)

each terminal

From external

Occupant sensor

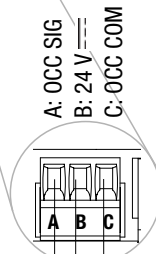

Control Wiring

Common and power (terminals 1 and 2):

Two #18 AWG (1.0 mm²) each terminal

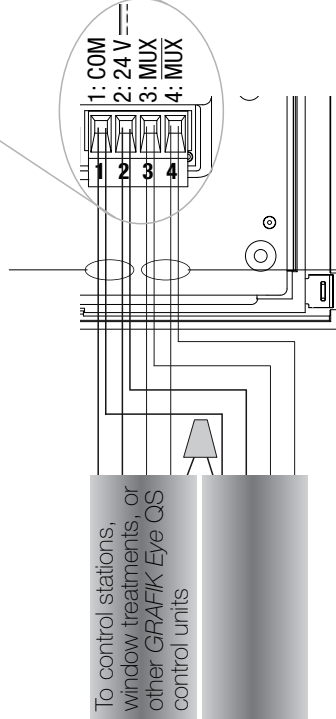

Data (terminals 3 and 4):

Twisted, shielded pair #22 AWG (1.0 mm²)

each terminal

Note: Use appropriate wire connecting devices as specified by local codes.

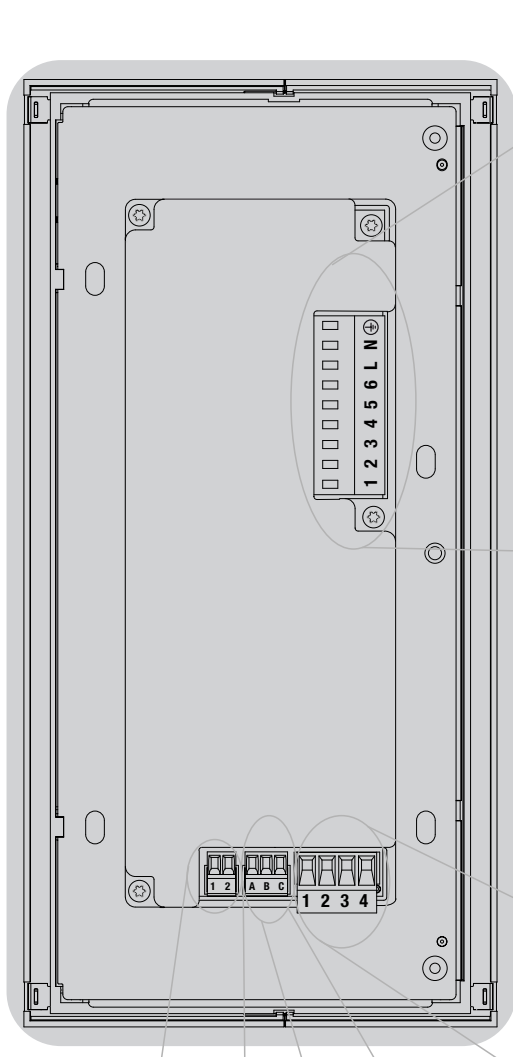

Line Voltage/Mains Cables and Load Wiring

#12 AWG (2.5 mm²)

each terminal

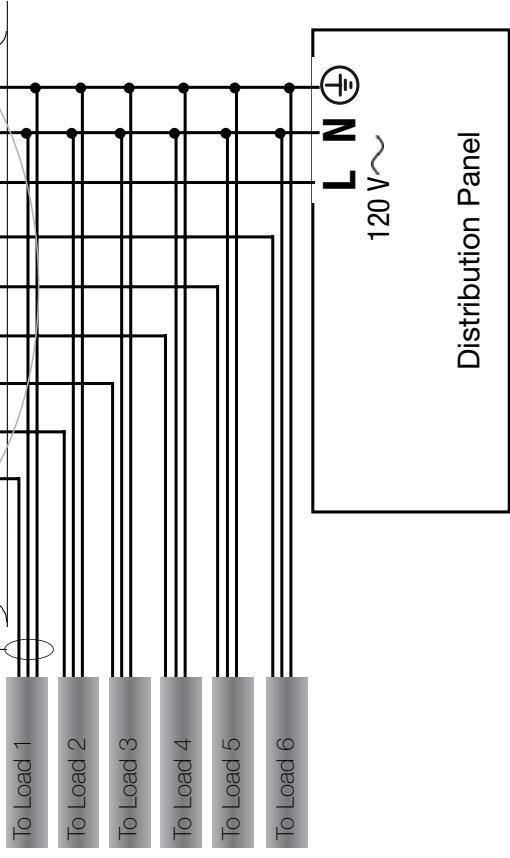

QS System Low-Voltage Control Wiring

- System communication uses PELV (Class 2: USA) low-voltage wiring.
- Follow all local and national electrical codes when installing PELV (Class 2: USA) wiring with line voltage/mains wiring.
- Each terminal accepts up to two #18 AWG (1.0 mm²) wires.
- Total length of control link must not exceed 2,000 ft. (610 m).
- Make all connections in the control unit's wallbox.
- A QS system can have up to 100 zones and 100 devices (see table below).
- Wiring can be T-tapped or daisy-chained.
- Wire sizes:
 - Two #18 AWG (1.0 mm²) conductors for control power.
 - One twisted, shielded pair of #22 AWG (1.0 mm²) for data link.
 - Cable is available from Lutron:
 - GRX-CBL-S-500 (non-plenum)
 - GRX-CBLP-S-500 (plenum rated).
 Check compatibility in your area.



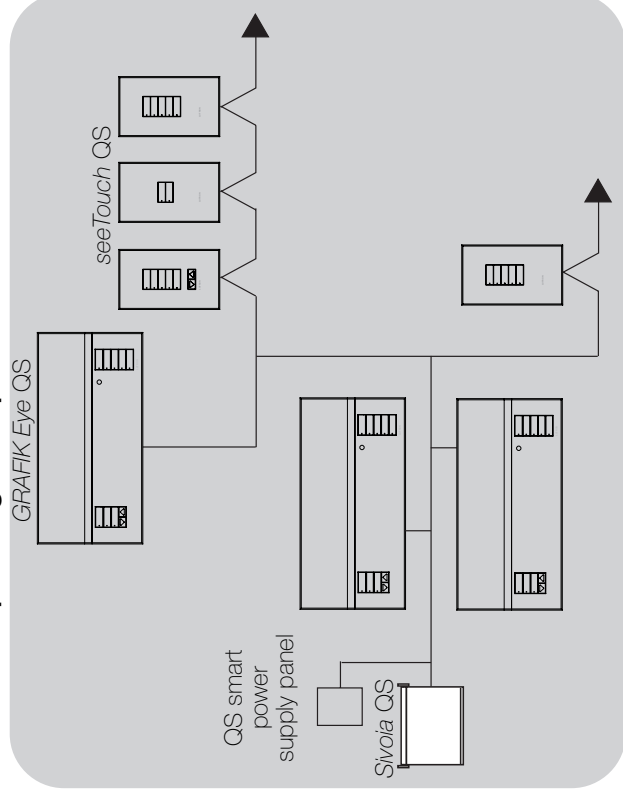

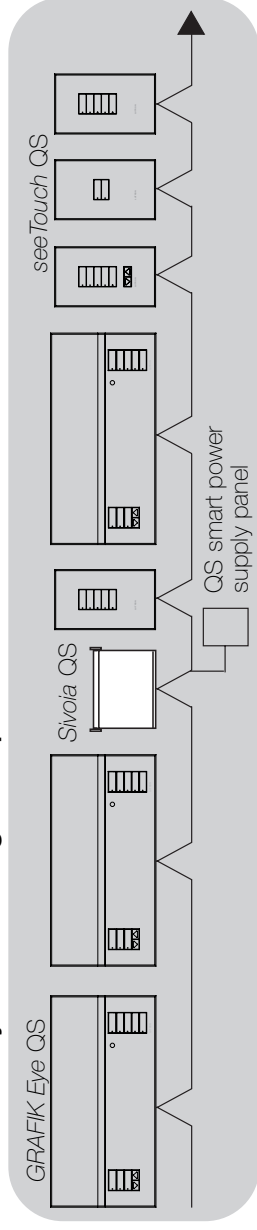

T-Tap Wiring Example



Daisy-Chain Wiring Example



System Limits

QS Device	Zone Count	Device Count
 3-zone QS	3	1
 4-zone QS	4	1
 6-zone QS	6	1
 <i>see Touch QS</i>	0	1
 Sivoia QS	1	1
 QS smart power supply panel	0	1

QS System Low-Voltage Terminal Connections

Control units shown in rear view

- Connect the terminal 1, 3, and 4 connections to all control units, wallstations, and control interfaces.
- Each control unit has its own power supply. Terminate the terminal 2 connection (24 VDC power) so that each control unit supplies power to a maximum of three wallstations. Each wallstation should receive power from only one control unit.

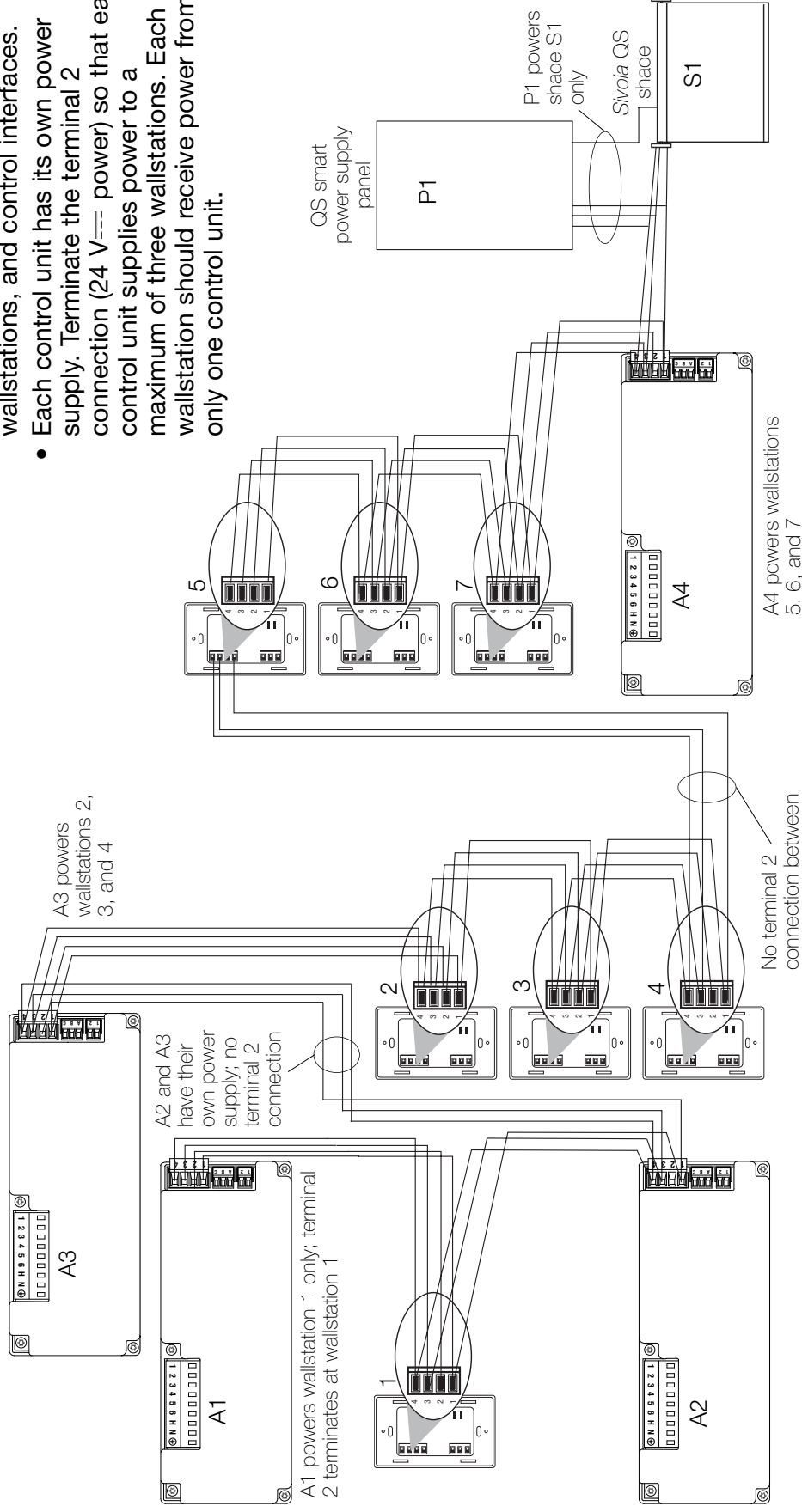

Installing the GRAFIK Eye® QS System

1. Mount a 3 1/2-in. (89 mm) deep 4-gang U.S. wallbox on a dry, flat indoor surface that is accessible and allows for system programming and operation. Allow at least 4 1/2 in. (110 mm) clearance above and below the faceplate to ensure proper heat dissipation. Allow 1 in. (25 mm) for faceplate overhang on all sides.

Note: 4-gang wallbox available from Lutron; P/N 241400.

2. Mount the control unit in the wallbox as shown using the four screws provided.

Note: Follow all local and national electrical codes when installing PELV (Class 2: USA) wiring with line voltage/mains wiring.

3. Apply the protective overlay to the control unit. See page 14 for instructions for naming zones.

Test the Wiring

1. Restore power.
2. Press the top button on the lighting keypad. The LED will light.
3. Press the zone raise or lower button. Make sure the control unit is dimming all connected loads.

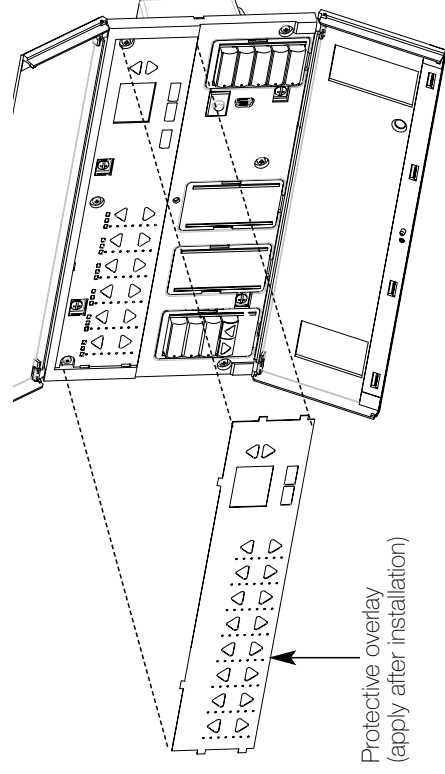
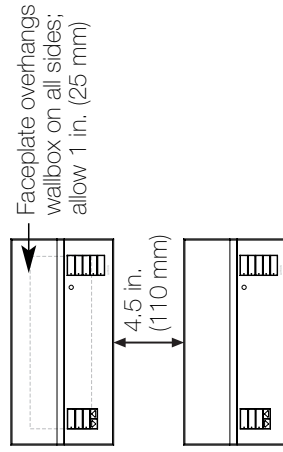
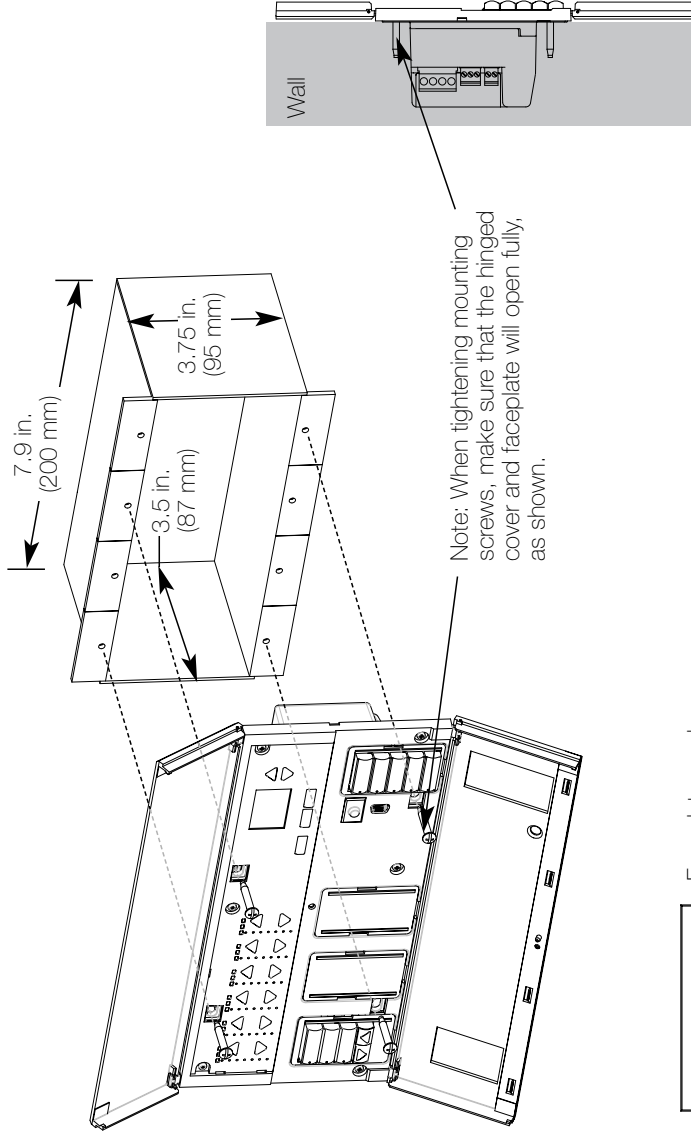

Zone Setup

Assign Load Type

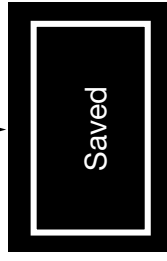
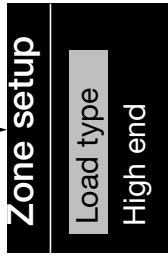

1. Enter programming mode (see page 12).
2. Use the master buttons to highlight “Zone setup” and press the OK button to accept.
3. Use the master buttons to highlight “Load type”. Press the OK button to accept.
4. Use the zone raise/lower buttons to choose the load type for that zone. See the list below for supported load types. Press the OK button to accept.
5. The info screen will display a confirmation screen that your load type has been saved.
6. Exit programming mode (see page 12).

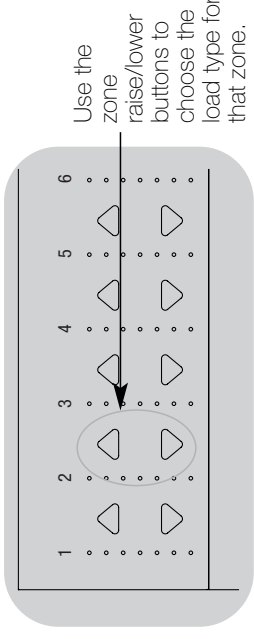
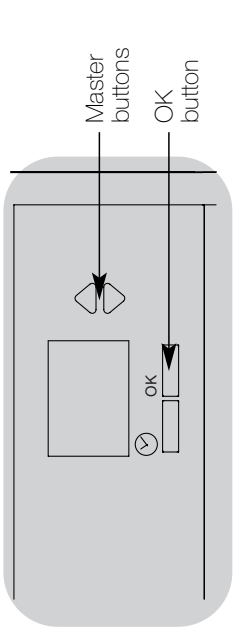

Load Type Notes

- All electronic low-voltage (ELV) lighting used with an interface must be rated for reverse phase control dimming. Before installing an ELV light source, verify with the manufacturer that their transformer can be dimmed. When dimming, an ELV interface must be used with the control unit.
- Not all zones must be connected; however, connected zones must have a minimum load of 25 W.
- No zone may be loaded with more than 800 W.
- Maximum total lighting load per unit is 16 A.
- Maximum total lighting load for a magnetic low-voltage (MLV) load is 2000 VA or 1600 watts after transformer. Maximum load per MLV zone is 800 VA or 600 watts.

Setting Load Types	Choose this load type from the menu on the GRAFIK Eye QS:
Fixture load type ↓ Incandescent MLV (magnetic low-voltage) ELV (electronic low-voltage) <i>Hi-Lume/Eco-10</i> Non-dim Neon/Cold cathode <i>Tu-Wire</i>	Direct control via GRAFIK Eye QS Incandescent MLV -- -- Non-dim LOFO or Non-dim FOFO Neon, CC <i>Tu-Wire</i>
	Control via power module Power module Power module Power module Fluorescent module Non-dim LOFO or Non-dim FOFO Neon, CC <i>Tu-Wire</i>

Zone Setup

Set High End or Low End

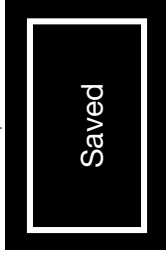
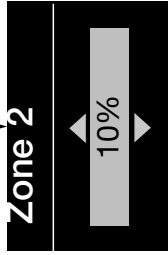
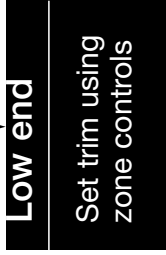
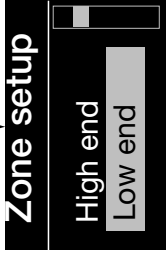

High and low end trim settings limit the maximum and minimum output of a dimming zone. Trim levels are set automatically when the load type is programmed. Change the high or low end trim for a zone only if the default setting needs to be adjusted.

1. Enter programming mode (see page 12).
2. Use the master buttons to highlight “Zone setup” and press the OK button to accept.
3. Use the master buttons to highlight “High end” or “Low end” (this example shows low end). Press the OK button to accept.
4. Use the zone raise/lower buttons to set the high end or low end trim for that zone.

The info screen will display each zone number and percentage as you adjust it. Press the OK button to accept.

5. The info screen will display a confirmation screen that your setting has been saved.

6. Exit programming mode (see page 12).

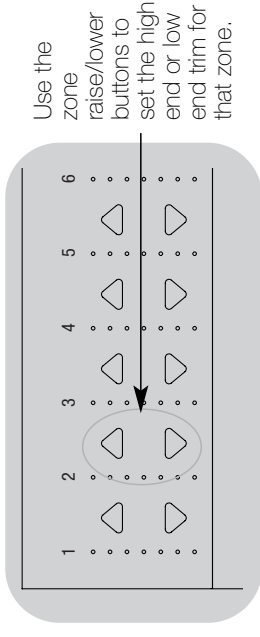
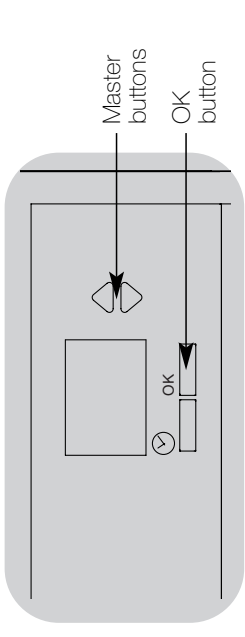

Use the zone raise/lower buttons to set the high end or low end trim for that zone.

Set Minimum Level (optional)

Some local regulations specify a minimum lighting level for dimming zones in occupied buildings. If this pertains to you, follow these steps to set up your minimum lighting level.

1. Enter programming mode (see page 12) and select “Zone setup,” then “Min level”. Press the OK button to accept.
2. Use the master buttons to highlight “OFF” if you want your lights to go all the way off at their minimum light level, or “10%” if you want that to be the minimum light level. Press the OK button to accept.

3. The info screen will display a confirmation screen that your minimum level has been saved.
4. Exit programming mode (see page 12).

Note: Non-dim loads will turn off regardless of the minimum level setting.

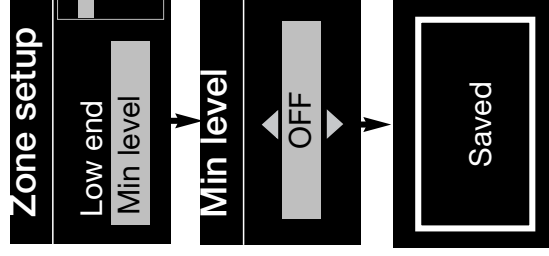

Preprogrammed Button Functionality

The GRAFIK Eye QS System controls lights without special programming. The factory defaults for the lighting column buttons are shown below for both dimmable and non-dim zones. See pages 15 through 17 for methods for changing scene settings.

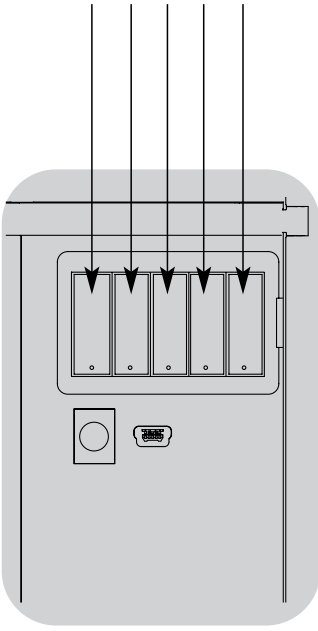

Lighting Column Button Preprogramming (Factory Default: Dimmable Loads)

- Scene 1: All lights to 100%
- Scene 2: All lights to 75%
- Scene 3: All lights to 50%
- Scene 4: All lights to 25%

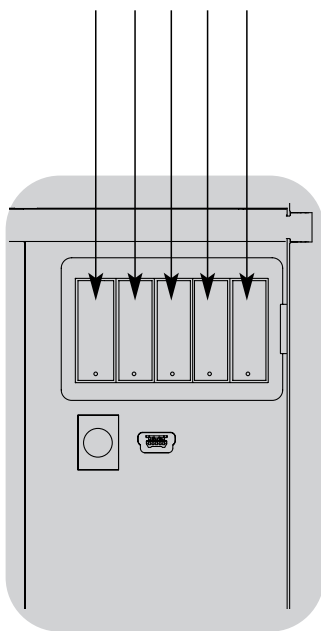

Lighting Column Button Preprogramming (Factory Default: Non-Dim Loads)

- Scene 1: All lights On
- Scene 2: All lights On
- Scene 3: All lights On
- Scene 4: All lights On

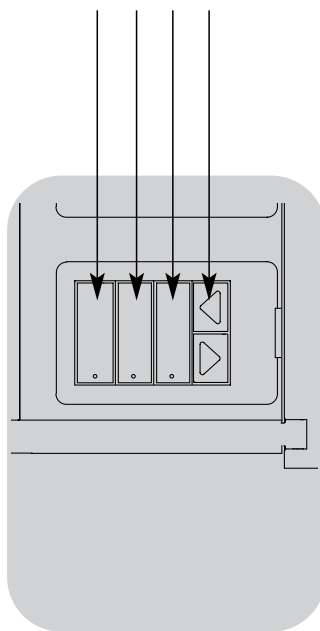

Shade Column Button Preprogramming (Factory Default: Sivoia QS shades)

- All shades fully open
- All shades to 50%
- All shades fully closed
- Lower/Raise all shades

General Functionality

The info screen goes blank after 20 seconds if there is no button press or fading.

The master buttons also activate the info screen. These buttons temporarily raise or lower all dimmable lights (except those programmed as unaffected in the current scene). Adjustments are temporary and do not affect scene programming.



The OK button activates the info screen, which then shows the current scene and its fade time.



The timeclock button activates the info screen and displays the current time, the next event scheduled to occur, and what that next event is. Pressing a second time displays the location and the sunrise/sunset times.

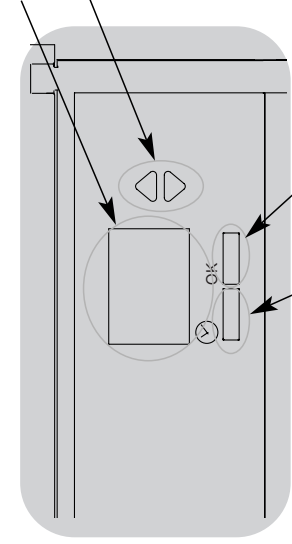

Info screen: see example screens below

Master buttons temporarily raise or lower all lights (except unaffected, shades, and non-dim zones) on this *GRAFIK Eye QS* unit

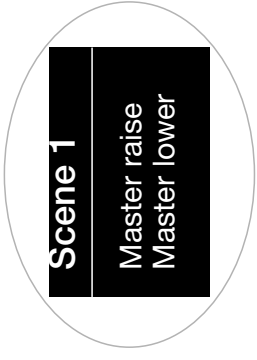

OK button activates the info screen, which shows the current scene's fade time. In Save Always mode, allows fade time adjustment. In



Save by OK mode, pressing a second time allows zone adjustment; pressing a third time allows fade adjustment.

Timeclock button displays the current time and the next scheduled event. Pressing when in Program mode functions as a "back" button.



General Functionality: Programming Mode

Entering and Exiting Programming Mode



To enter programming mode:

Press and hold simultaneously the top and bottom buttons on the lighting column for 3 seconds. The LEDs in the lighting buttons will scroll from top to bottom, confirming that you are in programming mode, and the info screen will display the main menu.



To exit programming mode:

Press and hold simultaneously the top and bottom buttons on the lighting column for 3 seconds. The info screen will go to Scene 1.

Info screen display when you exit programming mode

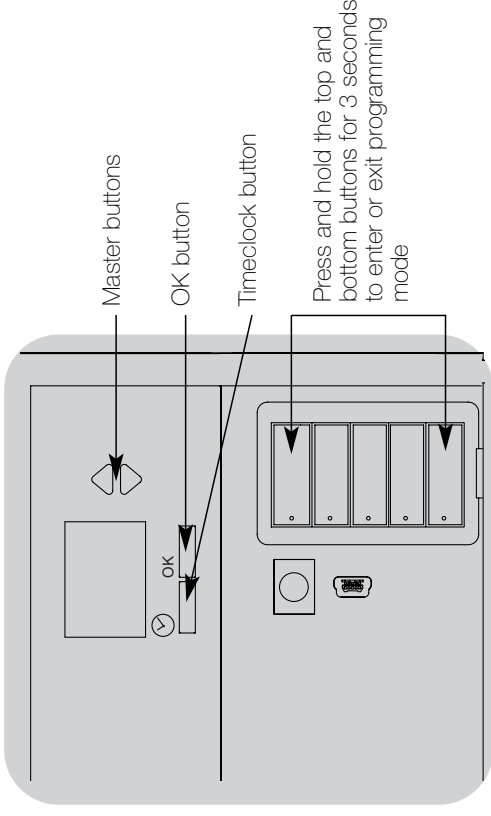

Navigating Menus in Programming Mode

Master Buttons

The master buttons allow you to move through the menu choices. The current choice is highlighted on the info screen.

OK Button

The OK button chooses the current highlighted menu choice. This will either take you to the next menu or accept a setting you have selected.

Timeclock Button

The timeclock button functions as a “back” button during programming mode. Pressing the timeclock button takes you back one step in the current menu. Pressing it repeatedly will eventually return you to the main menu, but will not exit programming mode.

Zone Button Operation

Each column of buttons represents one zone of lights. Pressing any button on a column turns on the info screen and displays the zone's current light level and current energy savings. Pressing the raise and lower buttons on a zone causes different actions depending on zone type (see below).

Dimmable zones:

- Press and hold to raise/lower all lights in a zone; release to stop
- Press raise or lower to stop a zone that is fading
- Raising lights from off to full on or lowering from full on to off takes 5 seconds
- Press raise and lower simultaneously to toggle between full on and off

Non-dim zones:

- Press raise to take light zones to full on
- Press lower to take light zones to off

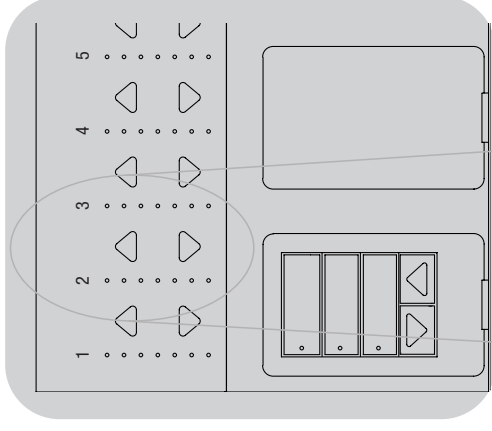

LEDs indicate light level
Note: See page 18 for an explanation of the LED display for each type of load in a zone.

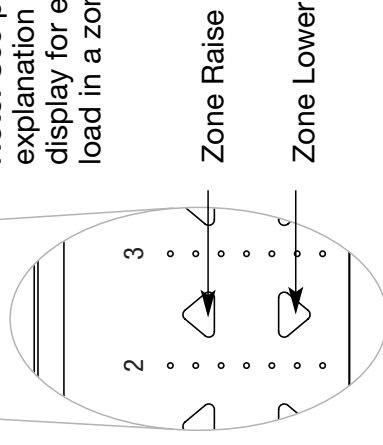

Zone Button Operation

Name a Zone

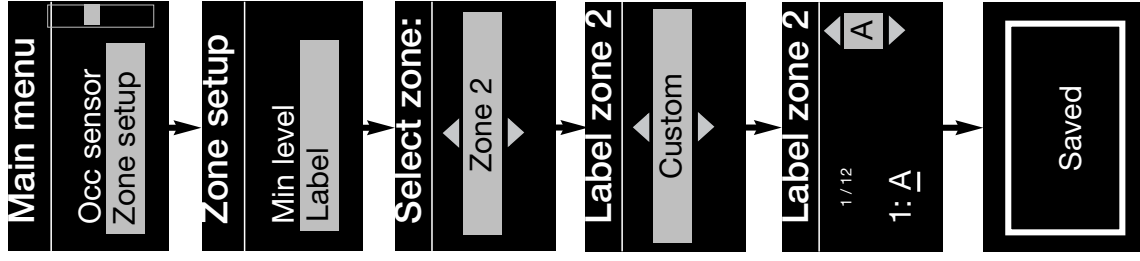

1. Enter programming mode (see page 12).
2. Use the master buttons to highlight “Zone setup” and press the OK button to accept.
3. Use the master buttons to highlight “Label” and press the OK button to accept.
4. Use the master buttons to change the zone number to your desired zone. Custom zone labels will appear if previously set. Press the OK button to accept.
5. Use the master buttons to highlight “Custom” and press the OK button to accept. Or, highlight “Default” to return the zone label to the default (e.g., Zone 1).
6. Use the master buttons to scroll through the characters (lowercase and uppercase letters, plus numbers 0-9). The character you are currently changing will be underlined on the screen. Press OK to select the character you want, then repeat for all available characters. Choose a space (no character) and press OK for any remaining characters. Press the OK button to accept.
Note: Custom zone labels will always begin with the zone number and a colon (e.g., 1:Uplights).
7. The info screen will display a confirmation screen that your name has been saved.
8. Exit programming mode (see page 12).

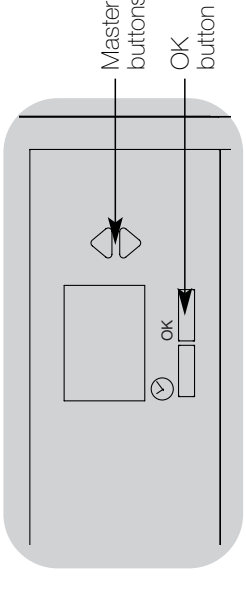

Quick Scene Programming

Save Always Mode

The default save mode (see page 28) is **Save Always**. This mode allows you to quickly set scenes on the lighting column without entering program mode.

1. Press the button for the scene you want to set; its LED will light and the lights will go to the current settings.
2. Use the zone raise/lower buttons to set all lights to the desired levels. Press the OK button.
3. To set the fade time for this scene, press the OK button, then use the master buttons to set the desired fade time. Press the OK button to save.

Note: Using the master buttons to raise or lower lighting settings is still temporary in **Save Always** mode.

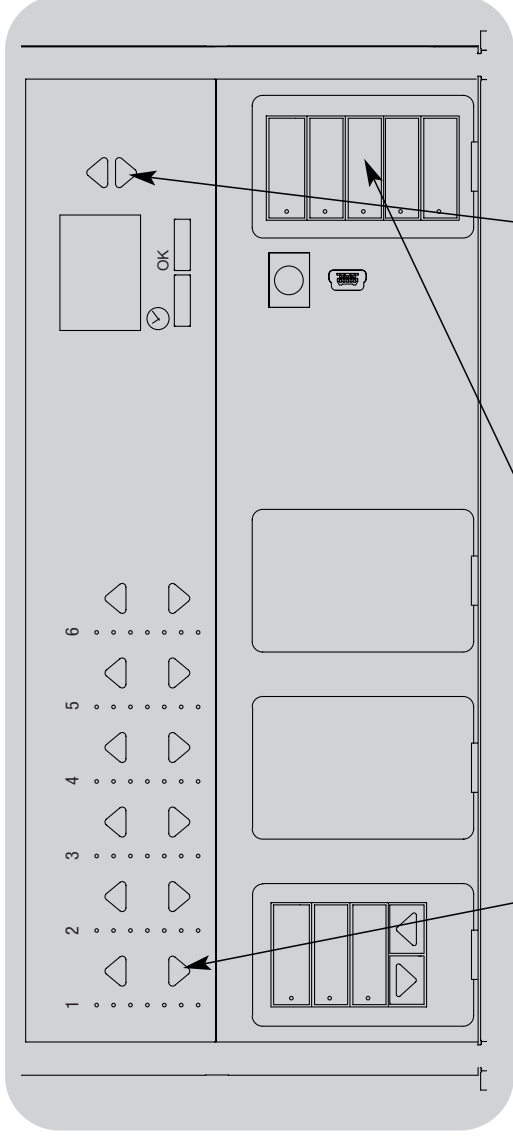

1. Press the lighting column scene button you wish to program.
2. Use the zone raise/lower buttons to set light levels.
3. Use the master buttons to set fade time.

Scene Setup

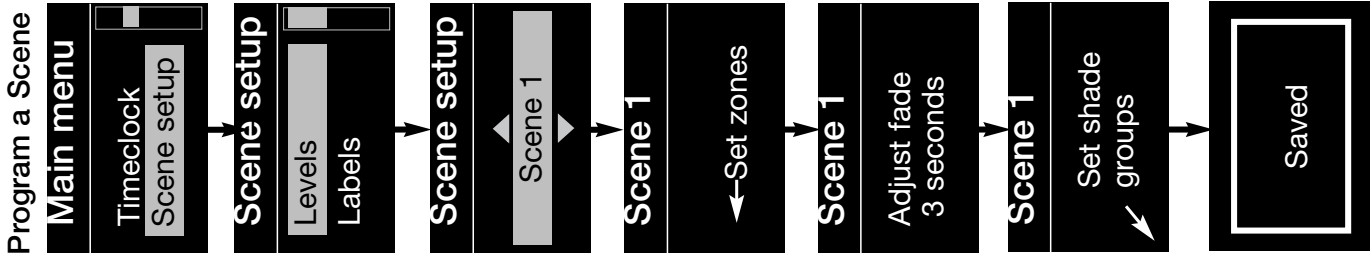

1. Enter programming mode (see page 12).
2. Use the master buttons to highlight “Scene setup” and press the OK button to accept.
3. Use the master buttons to select “Levels” to adjust lighting and/or window treatment levels. Press the OK button to accept. Use the master buttons to select the scene number of your desired scene. Press the OK button to accept.
4. Set each zone to the desired light level for this scene using the zone raise/lower buttons. The info screen will display the zone and percentage as you adjust it.
To set a zone as unaffected, lower the light levels all the way to off, then hold the zone lower button for 3 seconds. When all zones are at the desired level, press the OK button to accept.
5. Use the master buttons to set the fade time for this scene. Press the OK button to accept.
6. Press the button on a shade column that will take the window treatments assigned to that shade column to the level you want for this scene. Repeat for any additional shade columns. Press the OK button to accept. Or, if you do not have or do not wish to set shade groups for this scene, press OK.
7. The info screen will display a confirmation screen that your scene has been saved.
8. Exit programming mode (see page 12).

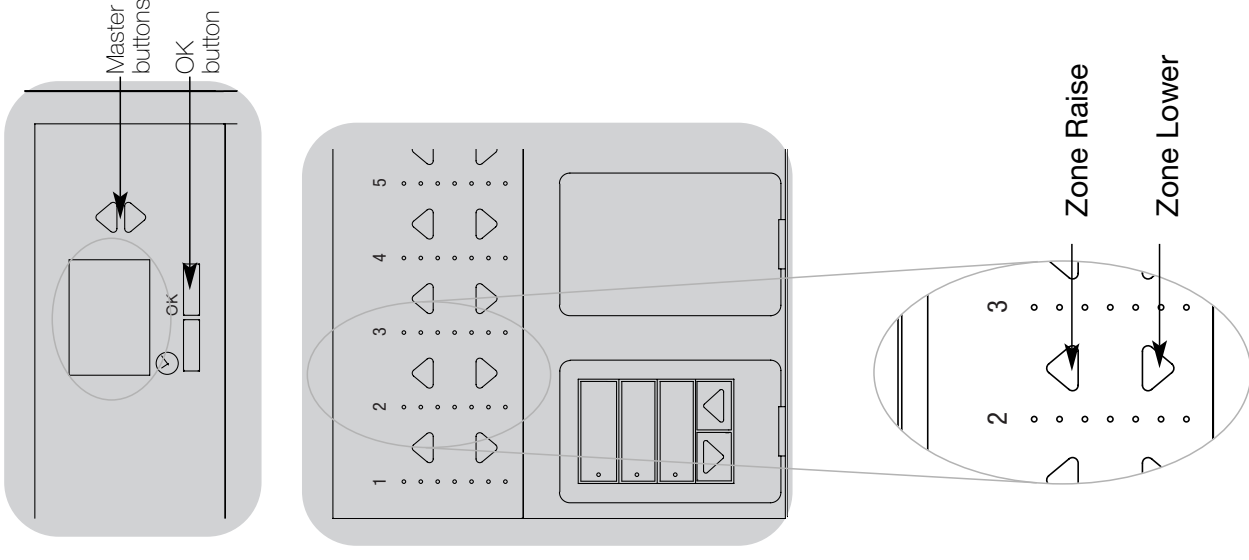

Scene Setup

Name a Scene

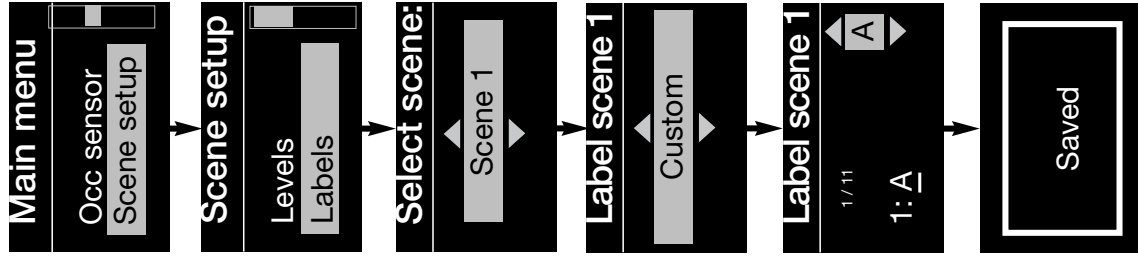

1. Enter programming mode (see page 12).
2. Use the master buttons to highlight “Scene setup” and press the OK button to accept.
3. Use the master buttons to highlight “Labels” and press the OK button to accept.
4. Use the master buttons to change the scene number to your desired scene. Press the OK button to accept.
5. Use the master buttons to highlight “Custom” and press the OK button to accept.
6. Use the master buttons to scroll through the characters (lowercase and uppercase letters, plus numbers 0-9). The character you are currently changing will be underlined on the screen. Press OK to select the character you want, then repeat for all available characters. Choose a space (no character) and press OK for any remaining characters. Press the OK button to accept.
7. The info screen will display a confirmation screen that your name has been saved.
8. Exit programming mode (see page 12).

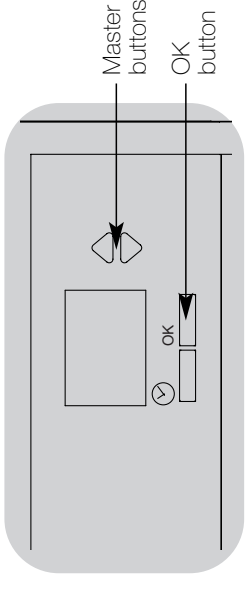

LED Displays for Lighting Levels

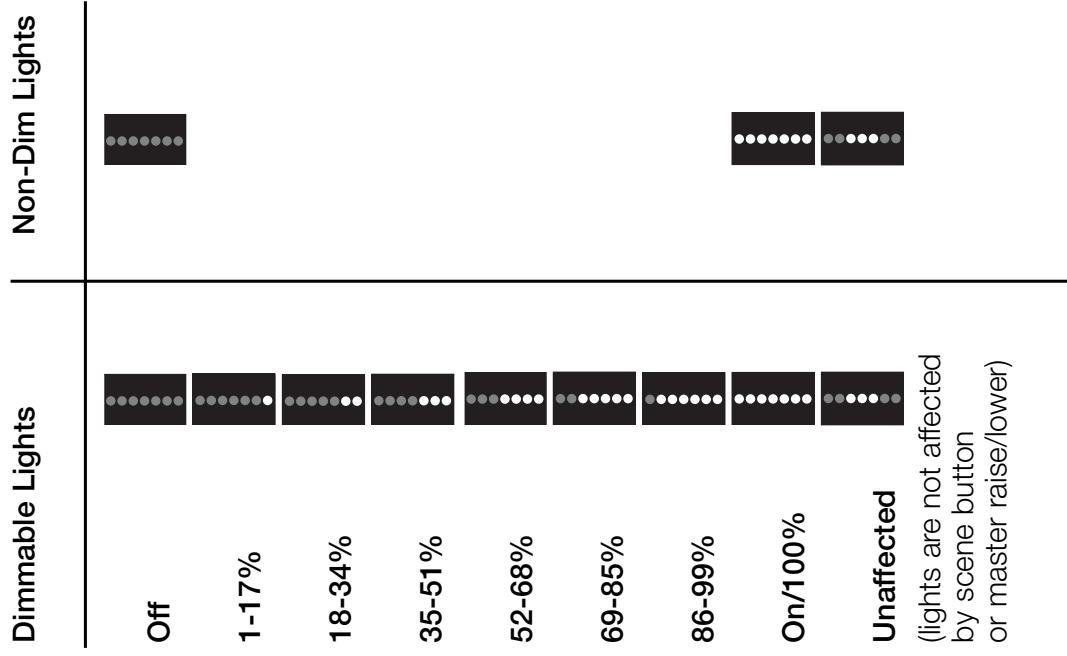

Legend:
 LED lit
 LED off

Adjusting Window Treatment Settings

Setting Limits



Note: Entering Limit Setup mode may cause window treatments to move approximately 8 inches up or down. Be sure that each window treatment is positioned so that the fabric can safely move 8 inches up or down before entering Limit Setup mode.

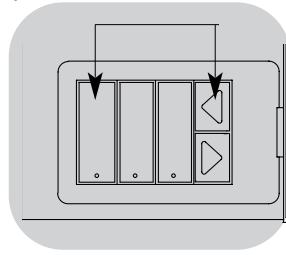

1. On any shade column, press and hold simultaneously the top and raise buttons. The LEDs next to the top and bottom buttons will cycle.

Note: At any time while in Limit Setup mode, you can move all window treatments together to their current open limit by double-tapping the top button, or to their current close limit by double-tapping the bottom button.

Note: Once EDUs (electronic drive units of the window treatment) have been assigned to shade columns, limits can be set for an EDU only using the shade column it is assigned to, and a shade column can set limits only for those EDUs assigned to it.

2. Select the EDU you want to adjust using the top button on the shade column. Each time you press and release the top button, a different EDU that is assigned to that shade column will open and close in an 8-inch range to indicate it is selected. Press the top button until the EDU for the window treatment you wish to adjust moves. (You can also use the bottom button, which moves through the assigned EDUs in the opposite order.)



3. Adjust the currently selected EDU to the desired level for the open limit (the maximum the window treatment is allowed to open) using the raise and lower buttons.

4. Press and hold the top button on the shade column for 5 seconds to store the current position as the open limit. The LED next to the top button will flash quickly for 2 seconds.

5. Adjust the currently selected EDU to the desired level for the close limit (the maximum the window treatment is allowed to close) using the raise and lower buttons.

6. Press and hold the bottom button on the shade column for 5 seconds to store the current position as the close limit. The LED next to the bottom button will flash quickly for 2 seconds.

7. Repeat steps 2 through 6 to set the open and close limits for each window treatment assigned to the shade column.

8. Press and hold simultaneously the top and raise buttons on the shade column to exit Limit Setup mode.

Adjusting Window Treatment Settings

Assigning EDUs to Shade Columns



Note: Entering Assignment mode will cause the window treatments to move between their open and close limits. **Be sure that the open and close limits have been set correctly.**

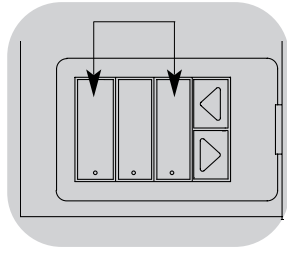

1. Press and hold simultaneously the top and bottom buttons on the shade column for 5 seconds to enter programming mode. The LEDs next to the buttons will flash once per second. EDUs (electronic drive units of the window treatments) assigned to that shade column will move to their close limit, and EDUs not assigned to that shade column will move to their open limit.

2. To assign an EDU to the shade column that is program mode, use one of the following methods:
 - Press and release the top button on the shade column that is in program mode. Each time you press and release the top button, a different EDU that is assigned to that shade column will open and close in an 8-inch range. Press the top button until the EDU you wish to assign to the shade column moves. (You can also use the bottom button, which moves through the EDUs in the opposite order.)

- Or, press and release any button on an EDU to toggle between unassignment and assignment for that EDU's window treatment to the shade column.

Assign or unassign the currently selected EDU to the shade column using the raise and lower buttons.

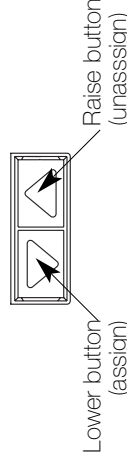

The lower button assigns the selected EDU.

The raise button unassigns the selected EDU.

3. Check window treatment assignments: EDUs for window treatments assigned to the shade column will be at their close limit, and EDUs for window treatments not assigned to the shade column will be at their open limit.

4. Press and hold simultaneously the top and bottom buttons on the shade column for 5 seconds to exit Assignment mode. The LEDs next to the buttons will stop flashing, and the EDUs assigned to the shade column will return to their levels before entering Assignment mode.

Note: Once you have assigned window treatments to a shade column, you will notice the following additional functionality:

- When some or all EDUs assigned to a shade column are moving, press and release the top, middle, or bottom button to immediately stop all assigned EDUs.
- The position that each EDU moves to when the middle button is pressed is now reprogrammable. See Preset Adjustment on page 21.
- No matter how or from where their movement is commanded, whenever all the assigned EDUs come to a stop and match their programmed positions for one of the buttons in the shade column, the LED next to that button will automatically light up.

Adjusting Window Treatment Settings

Preset Adjustment: Simple Method

1. Use the raise and lower buttons on the shade column to set all EDUs (electronic drive units of the window treatments) to the desired preset levels.



2. Press and hold the middle button on the shade column for 5 seconds to save the EDU preset positions. The LED next to the button will flash and then light continuously, indicating the preset has been stored.

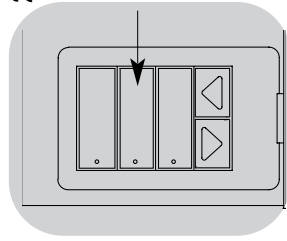

Note: Once EDU presets have been assigned to buttons on a shade column, those presets are accessible for an EDU only using the shade column it is assigned to, and a shade column can access preset levels only for those EDUs assigned to it.

Preset Adjustment: Advanced Method

Note: The advanced method for adjusting presets is needed only if you wish to have the window treatments assigned to the shade column set at different positions in the preset. If, however, you wish all the window treatments in the group to be lined up with one another in the preset, you should use the Simple Method at left.

Note: Entering Assignment mode will cause the window treatments to move between their open and close limits. **Be sure that the open and close limits have been set correctly.**

1. On the shade column whose preset you wish to adjust, press and hold simultaneously the top and bottom buttons. The LEDs next to the buttons will flash. EDUs (electronic drive units) for the assigned window treatments will move to their closed limits, and EDUs for unassigned window treatments will move to their open limits.

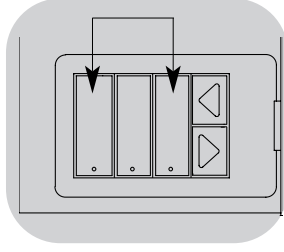

2. Press and release the middle button on that shade column. The adjacent LED will blink rapidly. EDUs for assigned window treatments will automatically move to their current preset settings.



3. Use the raise and lower buttons to move all EDUs for assigned window treatments together to the desired preset setting.

4. To move an EDU individually to its desired preset setting, select the EDU using the top button on the shade column. Each time you press and release the top button, a different EDU that is assigned to that shade column will open and close in an 8-inch range. Press repeatedly until the EDU for the window treatment you wish to adjust moves. Adjust that EDU to the desired height using the raise and lower buttons. Repeat this step for all assigned EDUs.
5. Once you are satisfied that all the assigned EDUs are set to the positions you want to assign as the preset, press and hold the middle button on the shade column for 5 seconds. The preset will be saved.
6. Press and hold simultaneously the top and bottom buttons on the shade column for 5 seconds to exit to normal mode. The LEDs next to the buttons will stop flashing.

Adjusting Window Treatment Settings

Name a Group of Window Treatments

1. Enter programming mode (see page 12).
2. Use the master buttons to highlight “Shade labels” and press the OK button to accept.
3. Use the master buttons to select your desired shade group. Press the OK button to accept.
4. Use the master buttons to highlight “Custom” and press the OK button to accept.
5. Use the master buttons to scroll through the characters (lowercase and uppercase letters, plus numbers 0-9). The character you are currently changing will be underlined on the screen. Press OK to select the character you want, then repeat for all available characters. Choose a space (no character) and press OK for any remaining characters. Press the OK button to accept.
6. The info screen will display a confirmation screen that your name has been saved.
7. Exit programming mode (see page 12).

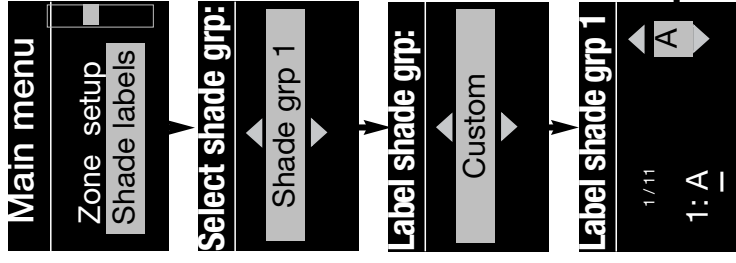
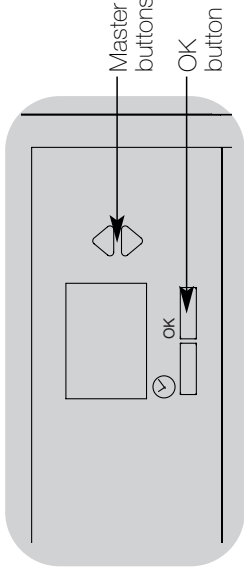

Remotely Restore EDUs to Factory Defaults



Warning! Restoring an EDU (electronic drive unit for a window treatment) to its factory defaults will erase any previous programming or assignments you have made for that EDU.



Note: Entering this mode may cause window treatments to move approximately 8 inches up or down. Be sure that each window treatment is positioned so that the fabric can safely move 8 inches up or down before entering this mode.

1. On any shade column, press and hold

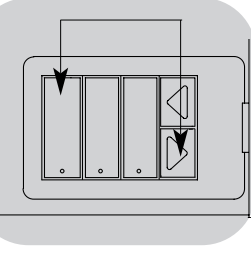

simultaneously the top and lower buttons. The LED next to the top button will flash.

2. Press and hold the top button for 5 seconds. All shade column LEDs will blink rapidly.



3. Select the EDU you want to restore to factory defaults using the top button on the shade column. Each time you press and release the top button, a different EDU in your system will open and close in an 8-inch range to indicate it is selected. Press the top button until the
4. Press and hold simultaneously the raise and lower buttons for 5 seconds to restore the moving shade to factory defaults.
5. Repeat steps 3 and 4 to restore factory defaults to any other window treatments.
6. Press and hold simultaneously the top and lower buttons on the shade column to exit this mode.

Timeclock Operation

Set Time and Date

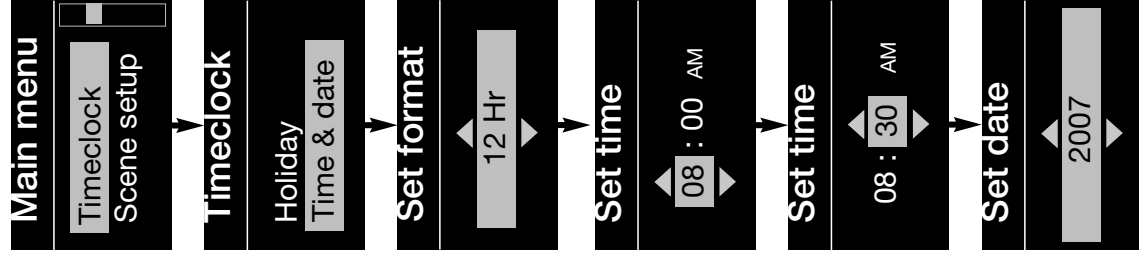

1. Enter programming mode (see page 12).
2. Use the master buttons to highlight “Timeclock” and press the OK button to accept.
3. Use the master buttons to highlight “Time & date” and press the OK button to accept.
4. Use the master buttons to select between “12 Hr” and “24 Hr” format for time display and press the OK button to accept.
5. Use the master buttons to select the current hour and press the OK button to accept. Repeat for the current minutes.
6. Use the master buttons to highlight the current year and press the OK button to accept. Repeat for the current month and date.
7. The info screen will display a confirmation screen that your time and date have been saved.
8. Exit programming mode (see page 12).

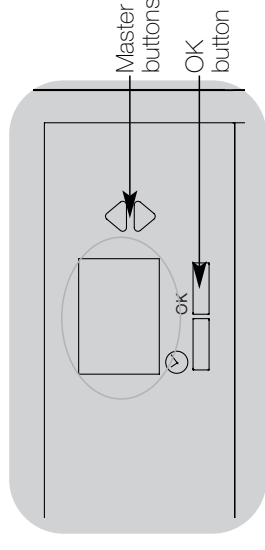

Timeclock Operation

Set Location

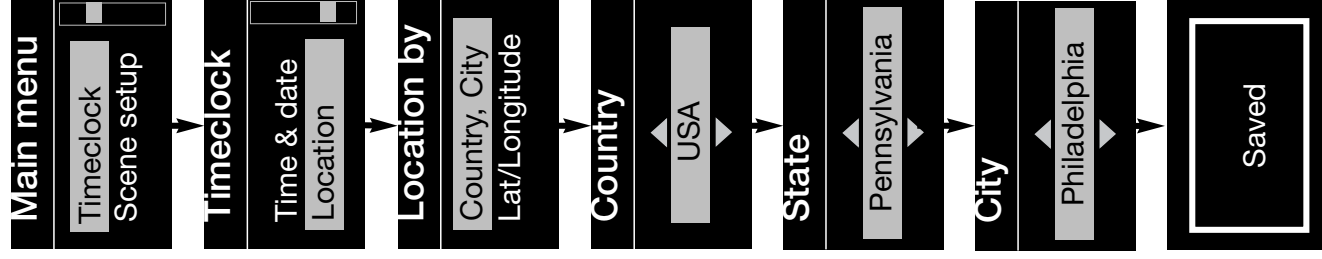

1. Enter programming mode (see page 12).
2. Use the master buttons to highlight “Timeclock” and press the OK button to accept.
3. Use the master buttons to highlight “Location” and press the OK button to accept.
4. Use the master buttons to choose to set your location by either country and city or latitude and longitude. Press the OK button to accept.
5. Use the master buttons to highlight the country and press the OK button to accept. Repeat for the state and closest city.
6. The info screen will display a confirmation screen that your time and date have been saved.
7. Exit programming mode (see page 12).

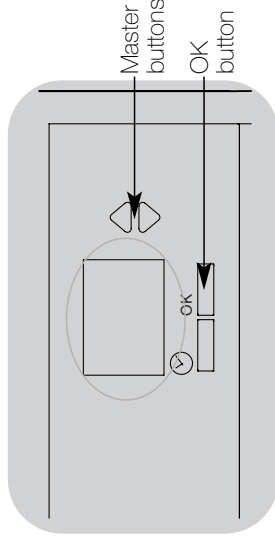

Set Daylight Saving Time

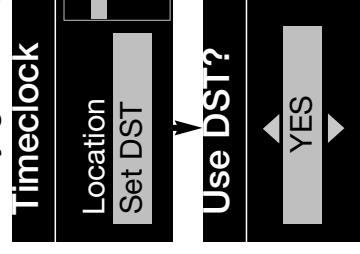

1. Enter programming mode (see page 12) and select “Timeclock”. Use the master buttons to highlight “Set DST” and press the OK button to accept.
2. Use the master buttons to highlight “YES” if your location observes daylight saving time, or “NO” if it does not. Press the OK button to accept.
3. If yes, use the master buttons to choose either “USA 2007” (the second Sunday in March to the first Sunday in November), or “Other.” For “Other,” follow the screens to set start and end dates and amount of time.
4. Press the OK button to accept. The info screen will display a confirmation screen that your time and date have been saved.
5. Exit programming mode (see page 12).

Timeclock Operation

Add an Event

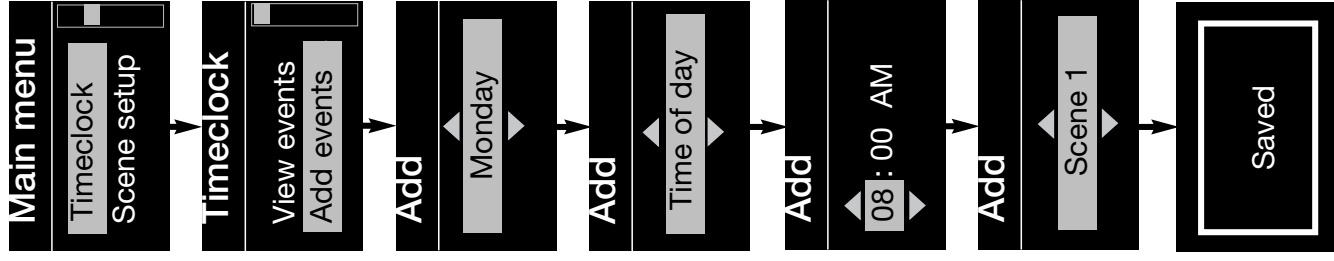

1. Enter programming mode (see page 12).
2. Use the master buttons to highlight “Timeclock” and press the OK button to accept.
3. Use the master buttons to highlight “Add events” and press the OK button to accept.
4. Use the master buttons to select the day of the week for this event; press the OK button to accept.
5. Use the master buttons to select the type of event (fixed time of day, or relative to sunrise or sunset); press the OK button to accept.
6. For a fixed-time event, use the master buttons to select the hour for your event to begin; press the OK button to accept. Repeat for the minutes. For a relative time event, use the master buttons and the OK button to set the hour, then the minutes relative to sunrise or sunset (maximum of 1 hour 59 minutes before or after sunrise or sunset).
7. Use the master buttons to select the scene you wish to activate for this event.
For a timeclock event involving only shades, scroll through the scenes to find the group of shades and the action (1, 2, or 3; open, preset, or close) you want to add to the timeclock event.
Or, press the button on the shade column that produces the action you want to add to this timeclock event.
Press the OK button to accept.
8. The info screen will display a confirmation screen that your event has been saved.
9. Exit programming mode (see page 12).

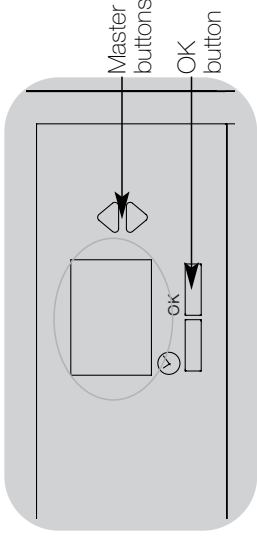

Timeclock Operation

Delete an Event

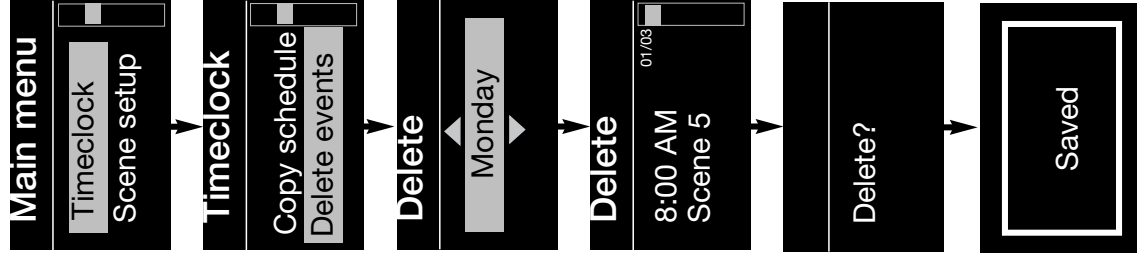

1. Enter programming mode (see page 12).
2. Use the master buttons to highlight “Timeclock” and press the OK button to accept.
3. Use the master buttons to highlight “Delete events” and press the OK button to accept.
4. Use the master buttons to select the day of the week (or holiday) when the event occurs; press the OK button to accept.
5. Use the master buttons to select the event to delete; press the OK button to accept.
6. A screen will appear, verifying you wish to delete the event. Press the OK button to accept and delete; otherwise, press the timeclock button to go back.
7. The info screen will display a confirmation screen that your event has been deleted.
8. Exit programming mode (see page 12).

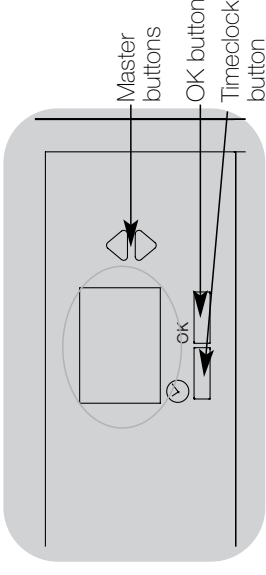

View an Event

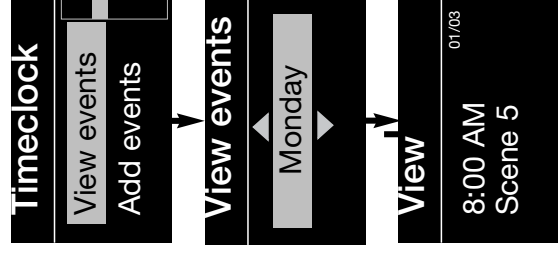

1. Enter programming mode (see page 12), select “Timeclock,” and select “View events”.
2. Use the master buttons to select the day of the week (or holiday) when the event occurs; press the OK button to accept.
3. Use the master buttons to select the event to view; press the OK button to accept.
4. Press the OK button to return to the Timeclock menu.
5. Exit programming mode (see page 12).

Timeclock Operation

Set a Holiday

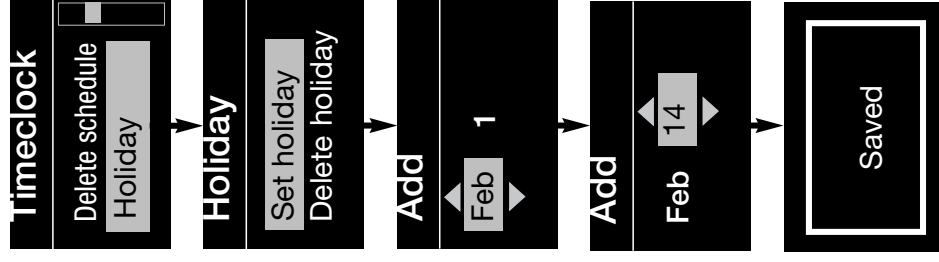

1. Enter programming mode (see page 12).
2. Use the master buttons to highlight “Timeclock” and press the OK button to accept.
3. Use the master buttons to highlight “Holiday” and press the OK button to accept.
4. Use the master buttons to select “Set holiday” and press the OK button to accept.
5. Use the master buttons to set the month of the holiday and press the OK button to accept. Repeat for the date.
6. The info screen will display a confirmation screen that your holiday has been set.
7. Exit programming mode (see page 12).

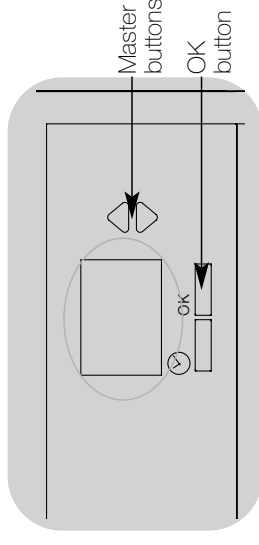

Delete a Holiday

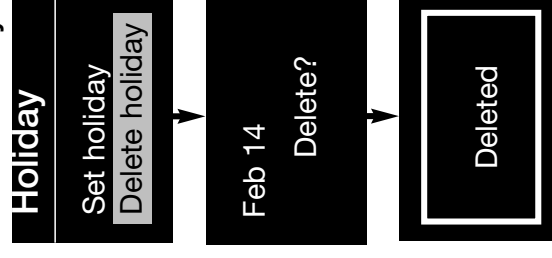

1. Enter programming mode (see page 12), select “Timeclock,” select “Holiday,” and select “Delete holiday”.
2. Use the master buttons to select the holiday you wish to delete and press the OK button to accept.
3. The info screen will display a confirmation screen that your event has been deleted.
4. Exit programming mode (see page 12).

Set Save Mode

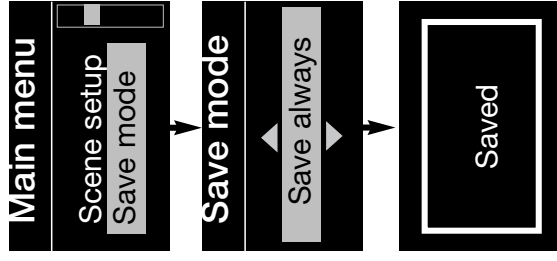

1. Enter programming mode (see page 12).
2. Use the master buttons to highlight “Save mode” and press the OK button to accept.
3. Use the master buttons to highlight the save mode you would like. The save modes are listed and explained below.
4. Press the OK button. The info screen will display a confirmation screen that your save mode has been saved.
5. Exit programming mode (see page 12).

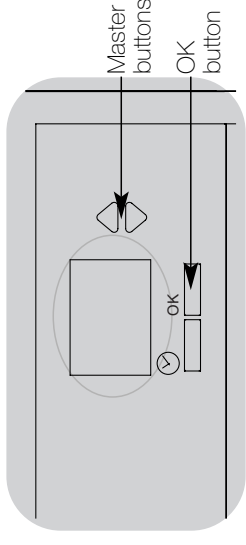

Save Modes

- Save always (default mode) . . . Quick scene programming mode; automatically save changes made to lighting levels or fade time (master raise/lower changes are temporary)
- Save by OK Zone adjustments are temporary unless the OK button precedes them
- Save never Do not save any temporary changes to lighting levels or fade time
- Four scenes Zone raise/lower buttons are disabled (typically used for rented spaces)
 - Master raise/lower buttons, wallstations, and IR receiver are still enabled for adjustment of light level, but these changes are not saved
 - Only the timeclock button, IR receiver, and wallstations can be used to make temporary changes (typically used in a public space)
- Button disable

Note: Off scene can be changed only through scene setup in program mode. Save modes will change only the fade time in Off scene settings.

Set Up Occupant Sensor

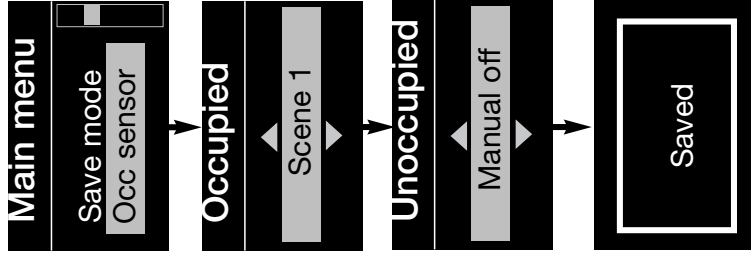

1. Enter programming mode (see page 12).
2. Use the master buttons to highlight “Occ sensor” and press the OK button to accept.
3. Use the master buttons to select the scene you wish to activate when the room is occupied.
For an occupant sensor setting involving only shades, scroll through the scenes to find the group of shades and the action (1, 2, or 3; open, preset, or close) you want to set.
Or, press the button on the shade column that produces the action you want to add to this timeclock event.
If your local lighting code requires it, you may also select “Manual on,” which means the occupant sensor will not automatically turn the lights on when someone enters a room. Instead, a button must be pressed manually.
4. Press OK to accept your choice.
5. Use the master buttons to select the scene you wish to activate when the room is unoccupied.
For an occupant sensor setting involving only shades, scroll through the scenes to find the group of shades and the action (1, 2, or 3; open, preset, or close) you want to set.
Or, press the button on the shade column that produces the action you want to add to this timeclock event.
You may also select “Manual off,” which means the occupant sensor will not trigger an action when the room is unoccupied.
6. Press OK to accept your choice. The info screen will display a confirmation screen that your occupant sensor settings have been saved.
7. Exit programming mode (see page 12).

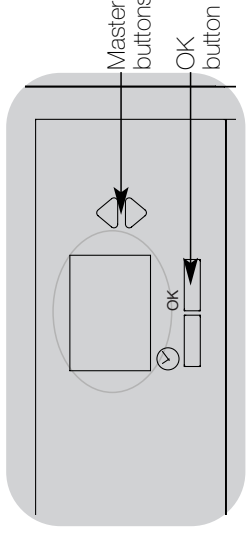

Occupied and Unoccupied Modes

- Occupied, contact closing The occupied scene occurs when an occupant sensor or contact closure connected to the occupant sensor input closes.
- Unoccupied, contact opening . . . The unoccupied scene occurs when an occupant sensor or contact closure connected to the occupant sensor input opens.

Activate System Accessories

Once your control unit is programmed, you will need to activate any accessories or interfaces that are a part of the system. Refer to the instructions that accompanied those devices to set them up for proper communication with the GRAFIK Eye QS control unit.

Faceplate Removal

The faceplates may need to be removed to change the color or to write in zone labels. To remove either faceplate, open it fully (flush to the wall), and pull up (for the top faceplate) or down (for the bottom faceplate) to pull the hinges out of their slots.

Replace by sliding the hinges back into their slots.

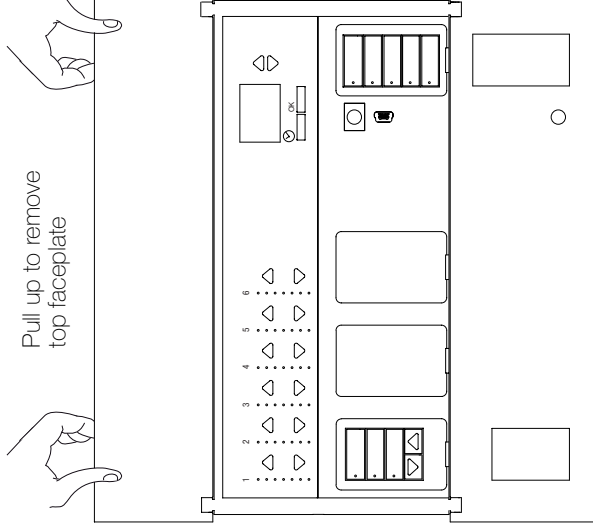

Pull down to remove bottom faceplate

Troubleshooting

Symptom	Possible Causes	Remedy
Unit does not control loads Unit does not turn lights on LEDs on front of unit are not ON MCB/breaker is tripping	Breaker/MCB is off Long fade time Low zone settings Miswire System short circuit System overload	Switch breaker/MCB on Set fade time to 0 seconds Reprogram scenes to a higher intensity Check wiring Find and correct shorts Make sure unit is not overloaded (2000 W max)
Unit does not control load ZONE control does not work	Miswire Disconnected wire Burned-out lamps	Check wiring Connect zone wires to loads Replace bad lamps
1 or more zones are "full on" when any scene is on and zone intensity is not adjustable	Miswire Shorted triac	Make sure loads are connected to the right zones Replace control unit
A Zone control affects more than one zone	Miswire	Check for shorts between zone outputs
Keypad buttons are not working Keypad LEDs are not tracking	Miswire or loose connection on low-voltage link Wallstation programming is incorrect	Tighten loose connections at PELV terminals on all units and other devices in the system Check the keypad function and programming on the units
Faceplate is warm	Normal operation	Solid-state controls dissipate about 2% of the connected load as heat.

Troubleshooting (continued)

Symptom	Possible Causes	Remedy
Unit does not allow scene change or zone adjustments	Unit in wrong save mode Keypad in system has locked the unit	Change to correct save mode Check programming and state of keypads
Screen is off	Normal operation	Screen turns off after 20 seconds
Occupant sensor input does not work	Miswire Incorrect programming Input closure/opening is not occurring Timeout on occupant sensor is set too long	Check wiring on contact closure input Re-program the occupied and unoccupied states of the input Check that the input device is opening and closing properly Set the occupant sensor timeout to a shorter time
Timeclock events do not occur Sunrise or sunset events do not occur at the correct time	Timeclock is disabled Time is not set correctly Date is not set correctly Location is not set correctly Holiday schedule is in effect	Enable the timeclock Set the time Set the date Set the latitude and longitude correctly Remove the holiday schedule from your programming

Troubleshooting (continued) - Window Treatment Functions

Symptom	Possible Causes	Remedy
EDU (electronic drive unit of the window treatment) will not move	EDU is not powered Window treatment fabric is caught on something EDU is not assigned to a keypad	Check EDU power Check and unbind window treatment fabric Assign the EDU to a keypad
EDU (electronic drive unit of the window treatment) does not fully open or fully close	Presets have been set incorrectly Limits have been set incorrectly Window treatment fabric is caught on something	Try using raise/lower buttons on keypad Set limits correctly Check and unbind window treatment fabric
Window treatment moves in the opposite direction when raise/lower buttons are pushed	Open and close limits have been reversed	Set limits correctly
Keypad LEDs are off and keypad will not control any window treatment	No power is going to keypad	Check and wire power to keypad
Keypad LEDs are on but keypad will not control any window treatment	All presets are set to the same height Communications link is not wired to the EDU EDU has been unassigned from keypad	Try using raise/lower buttons on keypad Check and wire the EDU link Reassign the EDU to the keypad
Keypad does not operate all the window treatments it is assigned to	EDU has been unassigned from keypad All presets are set to the same height EDU is not wired correctly Keypad is not wired correctly	Reassign the EDU to the keypad Try using raise/lower buttons on keypad Check and rewire EDU Check and rewire keypad
Window treatments in a room move on their own	EDUs are assigned to a keypad in another room	Reassign the EDU to the correct keypad

Menu Options

Timeclock

- View events
 - See [page 26](#)
- Add events
 - Copy all timeclock events from one day to another
 - Copy schedule
 - Copy all timeclock events from one day to another
- Delete events
 - See [page 26](#)
- Delete schedule
 - Delete all timeclock events from a specified day
- Holiday
 - See [page 27](#)
- Time & date
 - See [page 23](#)
- Location
 - See [page 24](#)
- Set DST
 - See [page 24](#)
- Enable/Disable
 - Enable or disable timeclock events
- Scene setup
 - Levels
 - See [page 16](#)
 - Labels
 - See [page 17](#)
- Save mode
 - See [page 28](#)
- Occ sensor
 - See [page 29](#)

Zone setup

- Load type
 - See [page 8](#)
- High end
 - See [page 9](#)
- Low end
 - See [page 9](#)
- Min level
 - See [page 9](#)
- Label
 - See [page 14](#)

Shade labels

- See [page 22](#)

IR

- Enabled
 - Enable control of the GRAFIK Eye by IR (remote control palm pilot, wired IR device, etc.)
- Disabled
 - Disable control of the GRAFIK Eye by IR (remote control palm pilot, wired IR device, etc.)

Backlight

- Off
 - Turn off the green backlights on the scene and shade buttons
- On
 - Turn on the green backlights on the scene and shade buttons

Diagnostics

Diagnostics are for advanced use only. For help, contact Lutron Technical Support.

Device serial

Displays the serial number of the GRAFIK Eye

Link details

Displays diagnostic information for all devices wired on the link

Code rev

Displays the software versions of the different components within the GRAFIK Eye USB status

Displays diagnostic information for the GRAFIK Eye's USB

Reset USB

Resets the USB module on the GRAFIK Eye (used if it is having trouble communicating)

Warranty

Lutron Electronics Co., Inc. One Year Limited Warranty

For a period of one year from the date of purchase, and subject to the exclusions and restrictions described below, Lutron warrants each new unit to be free from manufacturing defects. Lutron will, at its option, either repair the defective unit or issue a credit equal to the purchase price of the defective unit to the Customer against the purchase price of comparable replacement part purchased from Lutron. Replacements for the unit provided by Lutron or, at its sole discretion, an approved vendor may be new, used, repaired, reconditioned, and/or made by a different manufacturer.

If the unit is commissioned by Lutron or a Lutron approved third party as part of a Lutron commissioned lighting control system, the term of this warranty will be extended, and any credits against the cost of replacement parts will be prorated, in accordance with the warranty issued with the commissioned system, except that the term of the unit's warranty term will be measured from the date of its commissioning.

EXCLUSIONS AND RESTRICTIONS

This Warranty does not cover, and Lutron and its suppliers are not responsible for:

1. Damage, malfunction or inoperability diagnosed by Lutron or a Lutron approved third party as caused by normal wear and tear, abuse, misuse, incorrect installation, neglect, accident, interference or environmental factors, such as (a) use of incorrect line voltages, fuses or circuit breakers; (b) failure to install, maintain and operate the unit pursuant to the operating instructions provided by Lutron and the applicable provisions of the National Electrical Code and of the Safety Standards of Underwriter's Laboratories; (c) use of incompatible devices or accessories; (d) improper or insufficient ventilation; (e) unauthorized repairs or adjustments; (f) vandalism; or (g) an act of God, such as fire, lightning, flooding, tornado, earthquake, hurricane or other problems beyond Lutron's control.
2. On-site labor costs to diagnose issues with, and to remove, repair, replace, adjust, reinstall and/or reprogram the unit or any of its components.
3. Equipment and parts external to the unit, including those sold or supplied by Lutron (which may be covered by a separate warranty).
4. The cost of repairing or replacing other property that is damaged when the unit does not work properly, even if the damage was caused by the unit.

TO MAKE A WARRANTY CLAIM

To make a warranty claim, promptly notify Lutron within the warranty period described above by calling the Lutron Technical Support Center at (800) 523-9466. Lutron, in its sole discretion, will determine what action, if any, is required under this warranty, to better enable Lutron to address a warranty claim, have the unit's serial and model numbers available when making the call. If Lutron, in its sole discretion, determines that an on-site visit or other remedial action is necessary, Lutron may send a Lutron Services Co. representative or coordinate the dispatch of a representative from a Lutron approved vendor to Customer's site, and/or coordinate a warranty service call between Customer and a Lutron approved vendor.

This warranty gives you specific legal rights, and you may also have other rights which vary from state to state. Some states do not allow limitations on how long an implied warranty lasts, so the above limitation may not apply to you. Some states do not allow the exclusion or limitation of incidental or consequential damages, so the above limitation or exclusion may not apply to you.

These products may be covered under one or more of the following U.S. patents: 4,797,599; 4,893,062; 4,924,151; 5,191,265; 5,430,356; 5,463,286; 5,949,200; 5,990,635; 6,091,205; 6,188,181; 6,380,692; and corresponding foreign patents. Other U.S. and foreign patents may be pending.

Lutron, the sunburst logo, Sivoia, and GRAFIK Eye are registered trademarks of Lutron Electronics Co., Inc.
© 2007 Lutron Electronics Co., Inc.

EXCEPT AS EXPRESSLY PROVIDED IN THIS WARRANTY, THERE ARE NO EXPRESS OR IMPLIED WARRANTIES OF ANY TYPE, INCLUDING ANY IMPLIED WARRANTIES OF FITNESS FOR A PARTICULAR PURPOSE OR MERCHANTABILITY. LUTRON DOES NOT WARRANT THAT THE UNIT WILL OPERATE WITHOUT INTERRUPTION OR BE ERROR FREE.

NO LUTRON AGENT, EMPLOYEE OR REPRESENTATIVE HAS ANY AUTHORITY TO BIND LUTRON TO ANY AFFIRMATION, REPRESENTATION OR WARRANTY CONCERNING THE UNIT. UNLESS AN AFFIRMATION, REPRESENTATION OR WARRANTY MADE BY AN AGENT, EMPLOYEE OR REPRESENTATIVE IS SPECIFICALLY INCLUDED HEREIN, OR IN STANDARD PRINTED MATERIALS PROVIDED BY LUTRON, IT DOES NOT FORM A PART OF THE BASIS OF ANY BARGAIN BETWEEN LUTRON AND CUSTOMER AND WILL NOT IN ANY WAY BE ENFORCEABLE BY CUSTOMER.

IN NO EVENT WILL LUTRON OR ANY OTHER PARTY BE LIABLE FOR EXEMPLARY, CONSEQUENTIAL, INCIDENTAL OR SPECIAL DAMAGES (INCLUDING, BUT NOT LIMITED TO, DAMAGES FOR LOSS OF PROFITS, CONFIDENTIAL OR OTHER INFORMATION, OR PRIVACY; BUSINESS INTERRUPTION; PERSONAL INJURY; FAILURE TO MEET ANY DUTY, INCLUDING OF GOOD FAITH OR OF REASONABLE CARE; NEGLIGENCE, OR ANY OTHER PECUNIARY OR OTHER LOSS WHATSOEVER), NOR FOR ANY REPAIR WORK UNDERTAKEN WITHOUT LUTRON'S WRITTEN CONSENT ARISING OUT OF OR IN ANY WAY RELATED TO THE INSTALLATION, DEINSTALLATION, USE OF OR INABILITY TO USE THE UNIT OR OTHERWISE UNDER OR IN CONNECTION WITH ANY PROVISION OF THIS WARRANTY, OR ANY AGREEMENT INCORPORATING THIS WARRANTY, EVEN IN THE EVENT OF THE FAULT, TORT (INCLUDING NEGLIGENCE), STRICT LIABILITY, BREACH OF CONTRACT OR BREACH OF WARRANTY OF LUTRON OR ANY SUPPLIER, AND EVEN IF LUTRON OR ANY OTHER PARTY WAS ADVISED OF THE POSSIBILITY OF SUCH DAMAGES.

NOTWITHSTANDING ANY DAMAGES THAT CUSTOMER MIGHT INCUR FOR ANY REASON WHATSOEVER (INCLUDING, WITHOUT LIMITATION, ALL DIRECT DAMAGES AND ALL DAMAGES LISTED ABOVE), THE ENTIRE LIABILITY OF LUTRON AND OF ALL OTHER PARTIES UNDER THIS WARRANTY ON ANY CLAIM FOR DAMAGES ARISING OUT OF OR IN CONNECTION WITH THE MANUFACTURE, SALE, INSTALLATION, DELIVERY, USE, REPAIR, OR REPLACEMENT OF THE UNIT, OR ANY AGREEMENT INCORPORATING THIS WARRANTY, AND CUSTOMER'S SOLE REMEDY FOR THE FOREGOING, WILL BE LIMITED TO THE AMOUNT PAID TO LUTRON BY CUSTOMER FOR THE UNIT. THE FOREGOING LIMITATIONS, EXCLUSIONS AND DISCLAIMERS WILL APPLY TO THE MAXIMUM EXTENT ALLOWED BY APPLICABLE LAW, EVEN IF ANY REMEDY FAILS ITS ESSENTIAL PURPOSE.

Contact Information

Internet: www.lutron.com
E-mail: product@lutron.com

WORLD HEADQUARTERS

USA

Lutron Electronics Co., Inc.
7200 Suter Road, Coopersburg, PA 18036-1299
TEL +1.610.282.3800
FAX +1.610.282.1243
Toll-Free 1.888.LUTRON1
Technical Support 1.800.523.9466

Brazil

Lutron BZ do Brasil Ltda.
AV, Brasil, 239, Jardim America
Sao Paulo-SP, CEP: 01431-000, Brazil
TEL +55.11.3885.5152
FAX +55.11.3887.7138

North and South America Technical Hotlines

USA, Canada, Caribbean: 1.800.523.9466
Mexico: +1.888.235.2910
Central/South America: +1.610.282.6701

EUROPEAN HEADQUARTERS

United Kingdom

Lutron EA Ltd.
6 Sovereign Close, London, E1W 3JF United Kingdom
TEL +44.(0)20.7702.0657
FAX +44.(0)20.7480.6899
FREEPHONE (UK) 0800.282.107
Technical support +44.(0)20.7680.4481

France

Lutron LTC, S.A.R.L.
90 rue de Villiers, 92300 Levallois-Perret France
TEL +33.(0)1.41.05.42.80
FAX +33.(0)1.41.05.01.80
FREEPHONE 0800.90.12.18

Germany

Lutron Electronics GmbH, Landsberger Allee 201, 13055
Berlin, Germany
TEL +49.(0)30.9710.4590
FAX +49.(0)30.9710.4591
FREEPHONE 00800.5887.6635

Italy

Lutron LDV, S.r.l.
FREEPHONE 800.979.208

Spain, Barcelona

Lutron CC, S.R.L.
Gran Via del Carlos III, 84, planta 3ª,
08028, Barcelona, Spain
TEL +34.93.496.57.42
FAX +34.93.496.57.01
FREEPHONE 0900.948.944

Spain, Madrid

Lutron CC, S.R.L.
Calle Orense, 85, 28020 Madrid, Spain
TEL +34.91.567.84.79
FAX +34.91.567.84.78
FREEPHONE 0900.948.944

ASIAN HEADQUARTERS

Singapore

Lutron GL Ltd.
15 Hoe Chiang Road, #07-03 Euro Asia Centre,
Singapore 089316
TEL +65.6220.4666
FAX +65.6220.4333

China, Beijing

Lutron GL Ltd. Beijing Representative Office
5th Floor, China Life Tower
No. 16 Chaowai Street, Chaoyang District, Beijing
100020 China
TEL +86.10.5877.1817
FAX +86.10.5877.1816

China, Shanghai

Lutron GL Ltd., Shanghai Representative Office
Suite 07, 39th Floor, Plaza 66
1266 Nan Jing West Road, Shanghai, 200040 China
TEL +86.21.6288.1473
FAX +86.21.6288.1751

China, Hong Kong

Lutron GL Ltd.
Unit 2808, 28/F, 248 Queen's Road East
Wanchai, Hong Kong
TEL +852.2104.7733
FAX +852.2104.7633

Japan

Lutron Asuka Co. Ltd.
No. 16 Kowa Building, 4F, 1-9-20
Akasaka, Minato-ku, Tokyo 107-0052 Japan
TEL +81.3.5575.8411
FAX +81.3.5575.8420
FREEPHONE 0120.083.417

Asia Technical Hotlines

Northern China: 10.800.712.1536
Southern China: 10.800.120.1536
Hong Kong: 800.901.849
Indonesia: 001.803.011.3994
Japan: +81.3.5575.8411
Macau: 0800.401
Singapore: 800.120.4491
Taiwan: 00.801.137.737
Thailand: 001.800.120.665853
Other countries: +65.6220.4666



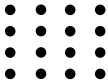
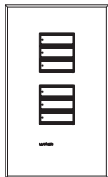
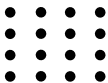
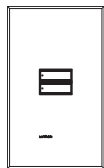

seeTouch® QS Wallstation Installation Guide

Please Read

Low-Voltage PELV (Class 2: USA)

24 V $\overline{\text{---}}$ 30 mA

- QSWS2-1B
- QSWS2-2B
- QSWS2-3B
- QSWS2-5B
- QSWS2-7B
- QSWS2-2BRL
- QSWS2-3BRL
- QSWS2-5BRL
- QSWS2-2BRLIR
- QSWS2-3BRLIR
- QSWS2-5BRLIR
- QSWS2-1RLD
- QSWS2-2RLD
- QSWS2-3BD

Wiring Notes

- System Maximums
 - GRAFIK Eye[®] QS series control units can each power a maximum of 3 wallstations.
 - 2000 ft. (610 m) maximum wiring length
 - 32-104 °F (0-40 °C) operating temperature.
 - 100 devices per link (see Touch[®] QS, Sivoia[®] QS, power panel, and GRAFIK Eye QS each count as one device); 100 zones maximum per link
- Refer to the system installation guide and Lutron job drawings for power cable and data cable (control link) wiring restrictions and limitations.
- Control Link Wiring
 - Power: Two #18 AWG (1.0 mm²) PELV (Class 2: USA) wires. Connect to terminals 1 and 2.
 - Data: Two shielded #22 AWG (1.0 mm²) PELV (Class 2: USA) wires (twisted, shielded pair). Connect to terminals 3 and 4.
Lutron offers a one-cable, non-plenum, low-voltage solution (P/N GRX-CBL-346S-500), and a one-cable, plenum, low-voltage solution (P/N GRX-PCBL-346S-500). Check availability outside the U.S.
- Sensor/Contact Closure Input Connector Wiring (optional):
 - Three #18 AWG (1.0 mm²) PELV (Class 2: USA) wires.
- Connect the wallstation to the control link inside the wallstation's wallbox or in a junction box (provided by others).
- Control link wiring must **not** be run in the same raceway as line voltage.
- Control link wiring is **not** to exceed 2000 ft. (610 m).
- The drain/shield wire must be maintained throughout the control link. Do **not** connect the shield to earth/ground or allow contact with the grounded wallbox.

Wallstation circuits are classified as Class 2 circuits (USA) and PELV circuits (IEC). As Class 2 circuits, they comply with the requirements of NFPA[®] 70, National Electrical Code[®] (NEC[®]). As PELV circuits, they comply with the requirements of IEC 60364-4-41, VDE 0100 Part 410, BS7671:1992, and other equivalent standards. When installing and wiring to these wallstations, follow all applicable national and/or local wiring regulations. External circuits connected to input, output, and other communication terminals of wallstations must be supplied from a listed Class 2 source or comply with the requirements for PELV circuits, as applicable in your country.

CAUTION!

- Read all instructions carefully before starting installation.
- Lutron recommends that wallstations be installed by a qualified electrician.
- Do not connect high-voltage power to low-voltage terminals. Improper wiring can result in personal injury or damage to the control or to other equipment.
- Use only a cloth with warm water and mild soap to clean faceplates (no chemical cleaners).

Installation



Warning! Always turn OFF the circuit breaker/MCB or remove the main fuse from the power line before doing any work. Failure to do so can result in serious personal injury.

1. **Turn Power OFF.** Turn power OFF at circuit breaker/MCB (or remove fuse).

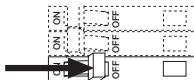

2. **Mount Wallbox.** Mount standard U.S. 1-gang wallbox, 2.75 in. (70 mm) deep (available from Lutron; P/N 241-519). Check availability outside the U.S.
3. **Prepare Wallstations.** Remove the faceplate and set aside.

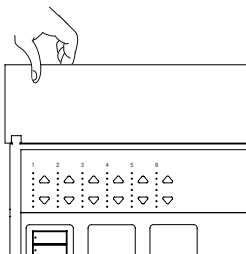

4. **Prepare wires.** Strip insulation from wires so that 3/8 in. (9.5 mm) of bare wire is exposed.



Each wallstation terminal accepts up to two #18 AWG (1.0 mm²) wires.

Note: Wiring may be done in a daisy-chain or T-tap configuration, as shown below.



Daisy chain

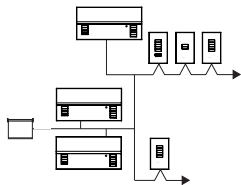

T-Tap

5. **Connect the Wallstation to the Control Link.**

Connect two #22 (1.0 mm²) shielded, twisted pair wires to terminals 3 and 4 of the wallstation's control link connector. Shielding (drain) of the twisted pair wires must be connected together as shown, but do **not** connect the shielding to earth/ground or the wallstation or allow contact with the grounded wallbox.

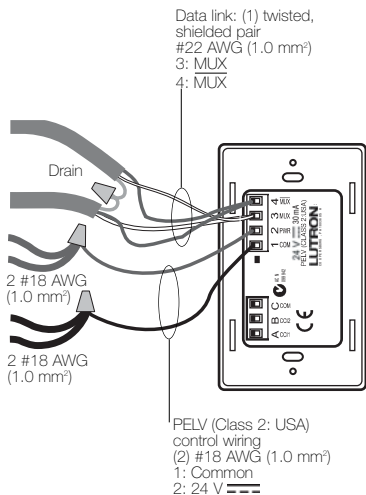

Control Link Wiring

Note: Use the wire connector required by local code (those shown are common in the US).

6. **Connect the Wallstation to external contact closure inputs (optional).**

If using one contact closure input, connect the input to terminal A of the wallstation sensor/contact closure input connector. If using two contact closure inputs, connect the inputs to terminals A and B. Connect the common side of the contact closure inputs to terminal C.

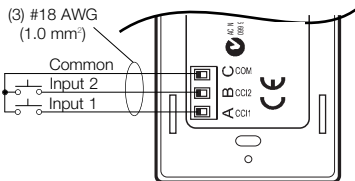

Contact Closure Input Wiring

Notes for Contact Closure Inputs:

Verify compatibility of external contact closure input devices. The contact closure inputs can be used with either dry contact closures or ground-referenced solid-state outputs. The outputs must stay in the closed or open states for at least 40 msec in order to be recognized by the wallstation. If there is any question as to whether the device is compatible with these specifications, contact the manufacturer.

Contact closure input function is determined by the programming of the top and bottom buttons of the wallstation.

7. **Mount Wallstation.** Carefully mount and align the wallstation as shown. Screw top and bottom screw into the control and wallbox. Replace faceplate, adapter (for insert versions), and button assembly.

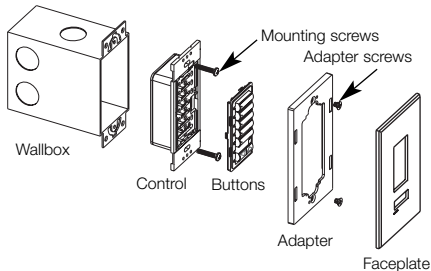

**Typical Mounting Diagram
(Exploded View)**

8. **Turn Power ON.** Turn ON control breaker, or replace main fuse.

Notes

- Unprogrammed (out of the box) QS wallstations and control units will all work together until they are reprogrammed otherwise.
- LEDs on wallstation buttons light when the scene programmed to it is the last scene activated.

System Communications

In order for wallstations to communicate with a control unit, each wallstation must be individually configured to "talk" to a "listening" control unit. In order for shade wallstations to control exclusively a given group of window treatments (as opposed to all window treatments in the system), each shade wallstation must be individually configured to "talk" to its respective window treatments. (Only one wallstation can be in setup mode at a time.)

1. **Enter Setup Mode.** Press and hold simultaneously for 3 seconds the top and bottom buttons (not including raise/lower buttons) on the wallstation. For 1-button wallstations, press and hold the single button for 10 seconds. (LEDs will flash periodically.)

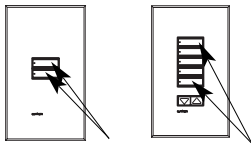

Press and hold the top and bottom buttons on your wallstation for 3 seconds to enter setup mode.

Note: For wallstations with two sets of buttons, you will program each set as if each were its own wallstation. For multigroup shade wallstations, first select the group, then program the wallstation for that group.

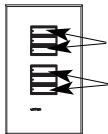

2. **Select wallstation function (optional).**

The info screen on the *GRAFIK Eye QS* control unit will display a prompt to change your wallstation's function (type).

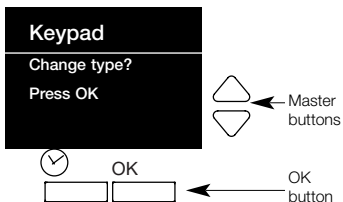

Press the OK button on the QS control unit to display the current wallstation function/type. To change, use the master buttons to scroll through the available choices until the function you want displays on the info screen.

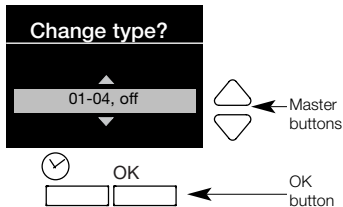

The keypad menu will display only functions that are available for the wallstation model that is "talking" to it. The example shown here is for a 5-button wallstation with raise/lower buttons.

Press the OK button to accept and save your highlighted choice.

Programming

The next step is to configure your wallstation that **GRAFIK Eye QS control unit or window treatment “listens”** when the wallstation “talks”, depending on your wallstation’s function. You will perform only one of Steps 3a through 3e for each wallstation.

3a. For wallstations with scene, panic, or sequence functions: Press and hold the top button on the **GRAFIK Eye QS control unit lighting column** until its LEDs flash in unison. Repeat for each control unit you want to “listen” to the wallstation for the selected function.

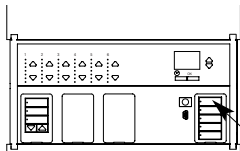

Press and hold the top button on the lighting column for 3 seconds to make control unit “listen”.

Note: To stop a control unit from “listening” to a wallstation, put the wallstation in setup mode, and press and hold for 3 seconds the **bottom** button on the lighting keypad of the control unit you want to stop listening.

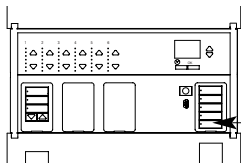

Press and hold for 3 seconds to make control unit stop “listening”.

Proceed to Step 4.

3b. For wallstations with partition function:

2-button wallstations that control one partition:

The LEDs on the wallstation will alternately blink.

On each **GRAFIK Eye QS control unit** within the partitioned space, press and hold the top button on the lighting column until its LEDs flash in unison. The control units will then function together when the partition is open.

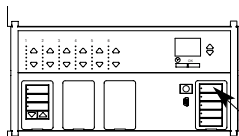

Press and hold the top button on the lighting column for 3 seconds to make control unit “listen”.

All other partition wallstations: On the wallstation, press the button you want to use to control partition function. Its LED will blink slowly. Then, on each **GRAFIK Eye QS control unit** that is related to that partitioned space, press and hold the top button on the lighting column until its LEDs flash in unison.

For multiple partitions, repeat for additional buttons on the partition wallstation, and the related control units.

Note: To stop a control unit from “listening” to a wallstation, put the wallstation in setup mode, then press and hold for 3 seconds the **bottom** button on the lighting keypad of the control unit you want to stop listening.

Proceed to Step 4.

3c. For Wallstations with fine tune function: On the *GRAFIK Eye QS* control unit, press simultaneously the raise and lower buttons for the zone you want the wallstation to fine tune. Repeat for each zone you wish to "listen" to the selected wallstation, or for zones on additional control units. When listening, zone LEDs flash. When unassigned (not "listening"), the 3 middle zone LEDs light.

Note: To stop a zone from listening to a wallstation, put the wallstation in setup mode, and press simultaneously the raise and lower buttons on the zone you want to stop listening.

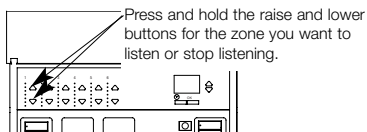

Proceed to Step 4.

3d. For wallstations with zone function: On the wallstation, press the button you want to program to toggle (alternate between) zones. Its LED will blink slowly.

On the *GRAFIK Eye QS* control unit, for the zone you want to "listen" to the wallstation, use the raise and lower buttons to set the desired levels. The LEDs will indicate the level. Then, press simultaneously those raise and lower buttons to listen that zone to the wallstation. When listening, zone LEDs flash. When not listening (unassigned), the 3 middle zone LEDs light.

Repeat for each zone you wish to assign to the selected wallstation, or for zones on additional control units.

Finally, repeat to program the remaining buttons on the wallstation with their respective zones.

Note: To stop a zone from listening to a wallstation, put the wallstation in setup mode, and press simultaneously the raise and lower buttons on the zone you want to stop listening.

Proceed to Step 4.

3e. For wallstations configured for shade function:

Note: Entering setup mode will cause the window treatments to move between their open and close limits. Be sure that the open and close limits have been set correctly (see page 12). Because your wallstation is configured for shade function, upon entering setup mode, EDUs (electronic drive units of window treatments) assigned to that wallstation will move to their close limit, and EDUs not assigned to it will move to their open limit.

To assign an EDU to the wallstation that is in setup mode, use one of the following methods:

Either - Press the top button on the wallstation. Each time you press the top button, a different EDU that is assigned to that wallstation will open and close in an 8-inch range. Press the top button until the EDU you wish to assign to the wallstation moves. (You can also use the bottom button, which moves through the EDUs in the opposite order.) Assign or unassign the currently selected EDU to the wallstation using the raise and lower buttons:

The lower button assigns the selected EDU.
The raise button unassigns the selected EDU.

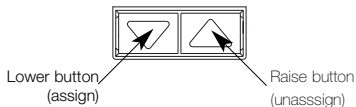

Or -Press any button on an EDU to toggle between unassignment and assignment for that EDU's window treatment to the wallstation.

Check window treatment assignments: EDUs for window treatments assigned to the wallstation will be at their close limit, and EDUs for window treatments not assigned to the wallstation will be at their open limit.

Note: Once you have assigned window treatments to a wallstation and exited setup mode, you will notice the following additional functionality:

- When some or all EDUs assigned to a wallstation are moving, press any button on the wallstation to immediately stop all assigned EDUs.
- The position that each EDU moves to when any but the top or bottom button is pressed is now programmable (see page 13).
- No matter how or from where their movement is commanded, whenever all the assigned EDUs come to a stop and match their programmed positions for one of the buttons on the wallstation, the LED next to that button will automatically light.

Proceed to Step 4.

4. **Exit Setup Mode.** Press and hold the top and bottom buttons on the wallstation simultaneously for 3 seconds. For 1-button wallstations, press and hold the single button for 10 seconds. The LEDs will return to normal.

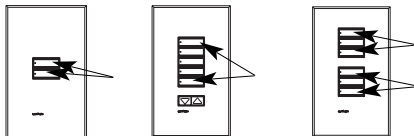

Press and hold the top and bottom buttons on your wallstation for 3 seconds to exit setup mode.

SeeTouch® QS Wallstation

Button Functions

The following functions are menu choices when the wallstation is in setup mode and the *GRAFIK Eye QS* is displaying the keypad menu. Each function choice is explained below. See the next page for a summary table of wallstations and their function choices.

Scenes: Choose from the list of preset groups of scenes to assign to the buttons on this wallstation. See the next page for a list of available scene groupings for each keypad.

Zone: Assigns control of one or more zones on one or more *GRAFIK Eye QS* control units to the selected wallstation button. Pressing a zone control button on a wallstation causes all assigned zones to go to the set level, with a fade time of 3 seconds (if all assigned zones are currently off). If any assigned zone is currently on (at any level), the LED for that zone will be lit, and pressing the wallstation button that controls that zone will cause all assigned zones to fade to off over 3 seconds. The 3-second fade time cannot be adjusted.

Partition: Used for rooms that can be divided by one or more partitions into smaller spaces. The LED on the assigned button indicates whether the partition should be considered open (LED is lit; control units work together as one) or closed (LED is off; control units work independently in separate spaces). A contact closure will open the partition; a contact opening will close the partition. Wallstations programmed for partitioning are only used for partitioning, and each button is configured to control different combinations of control units. When the partition between two *GRAFIK Eye QS* control units is open, the control units act together.

2B Partition: 2-button wallstations only. The top button indicates partition open, and the bottom button indicates partition closed.

2B Fine Tune: 2-button wallstations only. The buttons function as raise and lower buttons for the assigned zones. Zones are assigned by pressing the raise and lower buttons simultaneously; repeat to change assignments.

2B Sequence: 2-button wallstations only. This function scrolls through scenes 5 through 16 using their assigned fade rates, then repeats. For showroom-type applications. Program as you would for the Scene function.

2B Panic: 2-button wallstations only. Pressing the button sends all assigned zones immediately to scene 16, and locks out all button presses on all connected wallstations and control units. Program as you would for the Scene function.

Toggle: 1-button wallstations only. The button toggles between scene 1 and off.

Window treatments: Assign control of a group of shades to a wallstation.

Note: If a control unit has devices connected to it through contact closure inputs, CCI1 follows the top button and CCI2 follows the bottom button. The contact closure is equivalent to a button press.
Exception: On a 2-button wallstation, CCI1 closure action follows the top button and opening action follows the bottom button.

SeeTouch® QS Wallstation Button Functions Summary

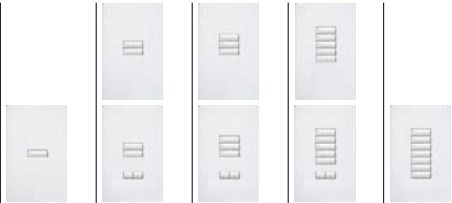
Keypad Function					
	1	2	3	5	7
Zone	X	X	X	X	X
Partition			X	X	X
2B Partition		X			
Clear				X	
Zone Lockout		X			
Fine Tune		X			
Sequence		X			
Panic		X			
Window Treatments		X	X	X	
Scene Options	1, Off (toggle)	1, Off 5, Off 9, Off 12, Off 1, 2 5, 6 9, 10 13, 14	1-3 5-7 9-11 13-15 1-2, Off 5-6, Off 9-10, Off 13-14, Off	1-4, Off 5-8, Off 9-12, Off 13-16, Off 1-5 5-9 9-13 13-16	1-7 9-15 1-6, Off 9-19, Off



Program as two
3-button keypads



Program as one 3-
button keypad and
one 2-button keypad



Program as two
2-button keypads

Notes

See the previous page for full explanations of the standard functions.

Wallstations with dual keypads: Each keypad functions independently and is programmed separately.

Wallstations with Raise/Lower buttons: These buttons function only when the wallstation function is either zone control or control of scenes.

Adjusting Window Treatment Settings

Setting Limits

Note: Entering Limit Setup mode may cause window treatments to move approximately 8 inches up or down. Be sure that each window treatment is positioned so that the fabric can safely move 8 inches up or down before entering Limit Setup mode.

To be able to adjust window treatment limits, your wallstation must have raise and lower buttons. If your model does not have these, please contact Lutron Technical Support or refer to your window treatment documentation to use the buttons on your EDU to manually set limits.



1. On your shade keypad, press and hold the top and raise buttons simultaneously for 3 seconds. The LEDs next to the top and bottom buttons will cycle.

Note: At any time while in Limit Setup mode, you can move all window treatments together to their current open limit by slowly double-pressing the top button, or to their current close limit by slowly double-tapping the bottom button.

Note: Once EDUs (electronic drive units of the window treatment) have been assigned to shade keypads, limits can be set for an EDU only using the shade keypad it is assigned to, and a shade keypad can set limits only for those EDUs assigned to it.

2. Select the EDU you want to adjust using the top button on the shade keypad. Each time you press the top button, a different EDU that is assigned to that shade keypad will open and close in an 8-inch range to indicate it is selected. Press the top button until the EDU for the window treatment you wish to adjust moves. (You can also use the bottom button, which moves through the assigned EDUs in the opposite order.)



3. Adjust the currently selected EDU to the desired level for the open limit (the maximum the window treatment is allowed to open) using the raise and lower buttons.
4. Press and hold the top button on the shade keypad simultaneously for 3 seconds to store the current position as the open limit. The LED next to the top button will flash quickly for 2 seconds.
5. Adjust the currently selected EDU to the desired level for the close limit (the maximum the window treatment is allowed to close) using the raise and lower buttons.
6. Press and hold the bottom button on the shade keypad for 3 seconds to store the current position as the close limit. The LED next to the bottom button will flash quickly for 2 seconds.
7. Repeat steps 2 through 6 to set the open and close limits for each window treatment assigned to the shade keypad.
8. Press and hold the top and raise buttons on the shade keypad simultaneously for 3 seconds to exit Limit Setup mode.

Preset Adjustment: Simple Method

Note: The top button will always open the shades fully, and the bottom button will always close the shades fully. Only the shade presets activated by the intermediate buttons can be reprogrammed.



1. Use the raise and lower buttons on the shade keypad to set all EDUs (electronic drive units of the window treatments) to the desired preset levels.



2. Press and hold the respective preset button on the shade keypad for 3 seconds to save the EDU preset positions. The LED next to the button will flash and then light continuously, indicating the preset has been stored.

Note: Once EDU presets have been assigned to buttons on a shade keypad, those presets are accessible for an EDU only using the shade keypad it is assigned to, and a shade keypad can access preset levels only for those EDUs assigned to it.

Preset Adjustment: Advanced Method

Note: The advanced method for adjusting presets is needed only if you wish to have the window treatments assigned to the shade keypad set at different positions in the preset. If, however, you wish all the window treatments in the group to be lined up with one another in the preset, you should use the Simple Method above.

Note: Entering Assignment mode will cause the window treatments to move between their open and close limits. Be sure that the open and close limits have been set correctly.

1. On the shade keypad whose preset you wish to adjust, press and hold the top and bottom buttons simultaneously for 3 seconds. The LEDs next to the buttons will flash. EDUs (electronic drive units) for the assigned window treatments will move to their closed limits, and EDUs for unassigned window treatments will move to their open limits.

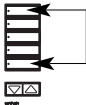

2. Press the preset button you wish to adjust on that shade keypad. The adjacent LED will blink rapidly. EDUs for assigned window treatments will automatically move to their current preset settings.



3. Use the raise and lower buttons to move all EDUs for assigned window treatments together to the desired preset setting.
4. To move an EDU individually to its desired preset setting, select the EDU using the top button on the shade keypad. Each time you press the top button, a different EDU that is assigned to that shade keypad will open and close in an 8-inch range. Press repeatedly until the EDU for the window treatment you wish to adjust moves. Adjust that EDU to the desired height using the raise and lower buttons. Repeat this step for all assigned EDUs you wish to adjust.
5. Once you are satisfied that all the assigned EDUs are set to the positions you want to assign as the preset, press and hold the respective preset button on the shade keypad for 3 seconds. The preset will be saved.
6. Press and hold the top and bottom buttons on the shade keypad simultaneously for 3 seconds to exit to normal mode. The LEDs next to the buttons will stop flashing.

Troubleshooting

Symptom

Possible Causes

No communication with *GRAFIK*
Eye control unit.

- Miswire or loose connection at the control link data lines 3 and 4.
 - Wallstation has not been programmed or has been programmed incorrectly.
-

Wallstation buttons do not work;
LEDs do not track.

- Wallstation is miswired.
 - Wallstation is not powered.
 - Wallstation is not wired to the correct set of lights.
 - Wallstation is not programmed to the correct device.
-

LEDs do not light.

- Miswire or loose connection at wallstation(s) or processor on the control link common and power connections 1 and 2.
 - Wallstation has been programmed incorrectly.
-

Contact closure inputs or sensor
input do not produce the desired
result in the system.

- Miswire or loose connection at wallstation sensor/CCI connector.
 - Wallstation has not been programmed or has been programmed incorrectly.
-

Wallstation buttons do not function
as intended.

- Wallstation has not been programmed or has been programmed incorrectly.
-

Troubleshooting: Window Treatment Functions

<u>Symptom</u>	<u>Possible Causes</u>	<u>Remedy</u>
EDU (electronic drive unit of the window treatment) will not move	EDU is not powered Window treatment fabric is caught on something EDU is not assigned to a keypad	Check EDU power Check and unbind window treatment fabric Assign the EDU to a keypad
EDU (electronic drive unit of the window treatment) does not fully open or fully close	Presets have been set incorrectly Limits have been set incorrectly Window treatment fabric is caught on something	Try using raise/lower buttons on keypad Set limits correctly Check and unbind window treatment fabric
Window treatment moves in the opposite direction when raise/lower buttons are pushed	Open and close limits have been reversed	Set limits correctly
Keypad LEDs are off and keypad will not control any window treatment	No power is going to keypad	Check and wire power to keypad
Keypad LEDs are on but keypad will not control any window treatment	All presets are set to the same height Communications link is not wired to the EDU EDU has been unassigned from keypad Open and close limits are the same	Try using raise/lower buttons on keypad Check and wire the EDU link Reassign the EDU to the keypad Set limits correctly
Keypad does not operate all the window treatments it is assigned to	EDU has been unassigned from keypad All presets are set to the same height EDU is not wired correctly Keypad is not wired correctly	Reassign the EDU to the keypad Try using raise/lower buttons on keypad Check and rewire EDU Check and rewire keypad
Window treatments in a room move on their own	EDUs are assigned to a keypad in another room	Reassign the EDU to the correct keypad

Warranty

Lutron Electronics Co., Inc. One Year Limited Warranty

For a period of one year from the date of purchase, and subject to the exclusions and restrictions described below, Lutron warrants each new unit to be free from manufacturing defects. Lutron will, at its option, either repair the defective unit or issue a credit equal to the purchase price of the defective unit to a customer against the purchase price of comparable replacement part purchased from Lutron. Replacements for the unit provided by Lutron or, at its sole discretion, an approved vendor may be new, used, repaired, reconditioned, and/or made by a different manufacturer.

If the unit is commissioned by Lutron or a Lutron approved third party as part of a Lutron commissioned lighting control system, the term of this warranty will be extended, and any credits against the cost of replacement parts will be prorated, in accordance with the warranty issued with the commissioned system, except that the term of the unit's warranty term will be measured from the date of its commissioning.

EXCLUSIONS AND RESTRICTIONS

This Warranty does not cover, and Lutron and its suppliers are not responsible for:

1. Damage, malfunction or inoperability diagnosed by Lutron or a Lutron approved third party as caused by normal wear and tear, abuse, misuse, incorrect installation, neglect, accident, interference or environmental factors, such as (a) use of incorrect line voltages, fuses or circuit breakers; (b) failure to install, maintain and operate the unit pursuant to the operating instructions provided by Lutron and the applicable provisions of the National Electrical Code and of the Safety Standards of Underwriter's Laboratories; (c) use of incompatible devices or accessories; (d) improper or insufficient ventilation; (e) unauthorized repairs or adjustments; (f) vandalism; or (g) an act of God, such as fire, lightning, flooding, tornado, earthquake, hurricane or other problems beyond Lutron's control.
2. On-site labor costs to diagnose issues with, and to remove, repair, replace, adjust, reinstall and/or reprogram the unit or any of its components.
3. Equipment and parts external to the unit, including those sold or supplied by Lutron (which may be covered by a separate warranty).
4. The cost of repairing or replacing other property that is damaged when a unit does not work properly, even if the damage was caused by the unit.

EXCEPT AS EXPRESSLY PROVIDED IN THIS WARRANTY, THERE ARE NO EXPRESS OR IMPLIED WARRANTIES OF ANY TYPE, INCLUDING ANY IMPLIED WARRANTIES OF FITNESS FOR A PARTICULAR PURPOSE OR MERCHANTABILITY. LUTRON DOES NOT WARRANT THAT THE UNIT WILL OPERATE WITHOUT INTERRUPTION OR BE ERROR FREE.

NO LUTRON AGENT, EMPLOYEE OR REPRESENTATIVE HAS ANY AUTHORITY TO BIND LUTRON TO ANY AFFIRMATION, REPRESENTATION OR WARRANTY CONCERNING THE UNIT, UNLESS AN AFFIRMATION, REPRESENTATION OR WARRANTY MADE BY AN AGENT, EMPLOYEE OR REPRESENTATIVE IS SPECIFICALLY INCLUDED HEREIN, OR IN STANDARD PRINTED MATERIALS PROVIDED BY LUTRON. IT DOES NOT FORM A PART OF THE BASIS OF ANY BARGAIN BETWEEN LUTRON AND CUSTOMER AND WILL NOT IN ANY WAY BE ENFORCEABLE BY CUSTOMER.

IN NO EVENT WILL LUTRON OR ANY OTHER PARTY BE LIABLE FOR EXEMPLARY, CONSEQUENTIAL, INCIDENTAL OR SPECIAL DAMAGES INCLUDING, BUT NOT LIMITED TO, DAMAGES FOR LOSS OF PROFITS, CONFIDENTIAL OR OTHER INFORMATION OR PRIVACY, BUSINESS INTERRUPTION, PERSONAL INJURY, FUTURE

TO MEET ANY DUTY, INCLUDING OF GOOD FAITH OR OF REASONABLE CARE; NEGLIGENCE, OR ANY OTHER PECUNIARY OR OTHER LOSS WHATSOEVER, NOR FOR ANY REPAIR WORK UNDERTAKEN WITHOUT LUTRON'S WRITTEN CONSENT ARISING OUT OF OR IN ANY WAY RELATED TO THE INSTALLATION, DEMONSTRATION, USE OF OR INABILITY TO USE THE UNIT OR OTHERWISE UNDER OR IN CONNECTION WITH ANY PROVISION OF THIS WARRANTY, OR ANY AGREEMENT INCORPORATING THIS WARRANTY, EVEN IN THE EVENT OF THE FAULT, TORT (INCLUDING NEGLIGENCE), STRICT LIABILITY, BREACH OF CONTRACT OR BREACH OF WARRANTY OF LUTRON OR ANY SUPPLIER, AND EVEN IF LUTRON OR ANY OTHER PARTY WAS ADVISED OF THE POSSIBILITY OF SUCH DAMAGES.

NOTWITHSTANDING ANY DAMAGES THAT CUSTOMER MIGHT INCUR FOR ANY REASON WHATSOEVER (INCLUDING, WITHOUT LIMITATION, ALL DIRECT DAMAGES AND ALL DAMAGES LISTED ABOVE), THE ENTIRE LIABILITY OF LUTRON AND OF ALL OTHER PARTIES UNDER THIS WARRANTY ON ANY CLAIM FOR DAMAGES ARISING OUT OF OR IN CONNECTION WITH THE MANUFACTURE, SALE, INSTALLATION, DELIVERY, USE, REPAIR, OR REPLACEMENT OF THE UNIT, OR ANY AGREEMENT INCORPORATING THIS WARRANTY, AND CUSTOMER'S SOLE REMEDY FOR THE FOREGOING, WILL BE LIMITED TO THE AMOUNT PAID TO LUTRON BY CUSTOMER FOR THE UNIT. THE FOREGOING LIMITATIONS, EXCLUSIONS AND DISCLAIMERS WILL APPLY TO THE MAXIMUM EXTENT ALLOWED BY APPLICABLE LAW, EVEN IF ANY REMEDY FAILS ITS ESSENTIAL PURPOSE.

TO MAKE A WARRANTY CLAIM

To make a warranty claim, promptly notify Lutron within the warranty period described above by calling the Lutron Technical Support Center at (800) 523-9466. Lutron, in its sole discretion, will determine what action, if any, is required under this warranty. To better enable Lutron to address a warranty claim, have the unit's serial and model numbers available when making the call. If Lutron, in its sole discretion, determines that an on-site visit or other remedial action is necessary, Lutron may send a Lutron Services Co. representative or coordinate the dispatch of a representative from a Lutron approved vendor to Customer's site, and/or coordinate a warranty service call between Customer and a Lutron approved vendor.

This warranty gives you specific legal rights, and you may also have other rights which vary from state to state. Some states do not allow limitations on how long an implied warranty lasts, so the above limitation may not apply to you. Some states do not allow the exclusion or limitation of incidental or consequential damages, so the above limitation or exclusion may not apply to you.

These products may be covered under one or more of the following U.S. patents: D461,782; and corresponding foreign patents. Other U.S. and foreign patents may be pending.

National Electric Code, NEC, and NFPA are registered trademarks of the National Fire Protection Association, Inc., Quincy, Massachusetts.

Lutron, the sunburst logo, Sivoia, seeTouch, and GRAFik Eye are registered trademarks of Lutron Electronics Co., Inc.

© 2007 Lutron Electronics Co., Inc.

Contact Information

Internet: www.lutron.com
E-mail: product@lutron.com

WORLD HEADQUARTERS USA

Lutron Electronics Co., Inc.
7200 Suter Road, Coopersburg, PA
18036-1299
TEL +1.610.282.3800
FAX +1.610.282.1243
Toll-Free 1.888.LUTRON1
Technical Support 1.800.523.9466

North and South America Technical Offices

USA, Canada, Caribbean: 1.800.523.9466
Mexico: +1.888.235.2910
Central/South America: +1.610.282.6701

EUROPEAN HEADQUARTERS United Kingdom

Lutron EA Ltd.
6 Sovereign Close, London,
E1W 3JF United Kingdom
TEL +44.(0)20.7702.0657
FAX +44.(0)20.7480.6899
FREEPHONE (UK) 0800.282.107
Technical Support +44.(0)20.7680.4481

ASIAN HEADQUARTERS Singapore

Lutron GL Ltd.
15 Hoe Chiang Road,
#07-03 Euro Asia Center, Singapore 089316
TEL +65.6220.4666
FAX +65.6220.4333

Asia Technical Offices

Northern China: 10.800.712.1536
Southern China: 10.800.120.1536
Hong Kong: 800.901.849
Indonesia: 001.800.011.3994
Japan: +81.3.5575.8411
Macau: 0800.401
Singapore: 800.120.4491
Taiwan: 00.801.137.737
Thailand: 001.800.120.665853
Other countries: +65.6220.4666



Lutron Electronics Co., Inc.
Made and printed in U.S.A.
P/N 030-939 Rev. A 10/07



Please refer to the enclosed CD for the product Specification Sheets and Operation Manuals, Ethernet Device IP program, and RS232 Protocol information.

PELV (Class 2: USA) Devices 12 - 24 V_{DC} 200 mA

Mounting

1. Mount the Control Interface directly on a wall, as shown in the Mounting Diagram, using screws (not included). When mounting, provide sufficient space for connecting cables. The unit can also be placed in the LUT-19AV-1U AV rack using the screws provided with the unit. The LUT-19AV-1U will hold up to four units. If conduit is desired for wiring, the LUT-5x10-ENC can be used to mount one unit.
2. Strip 3/8 in. (10 mm) of insulation from wires. Each Data Link terminal will accept up to two #18 AWG (1.0 mm²) wires.
3. Connect wiring as shown in the Wiring Diagram (next page). LED 1 lights continuously (Power) and LED 7 blinks rapidly (Data Link RX) when the Class 2 (PELV) Data Link is installed correctly.

Mounting Diagram

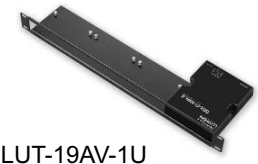
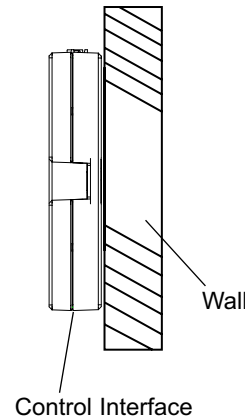

LUT-19AV-1U



LUT-5x10-ENC

Dimensions

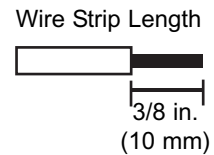
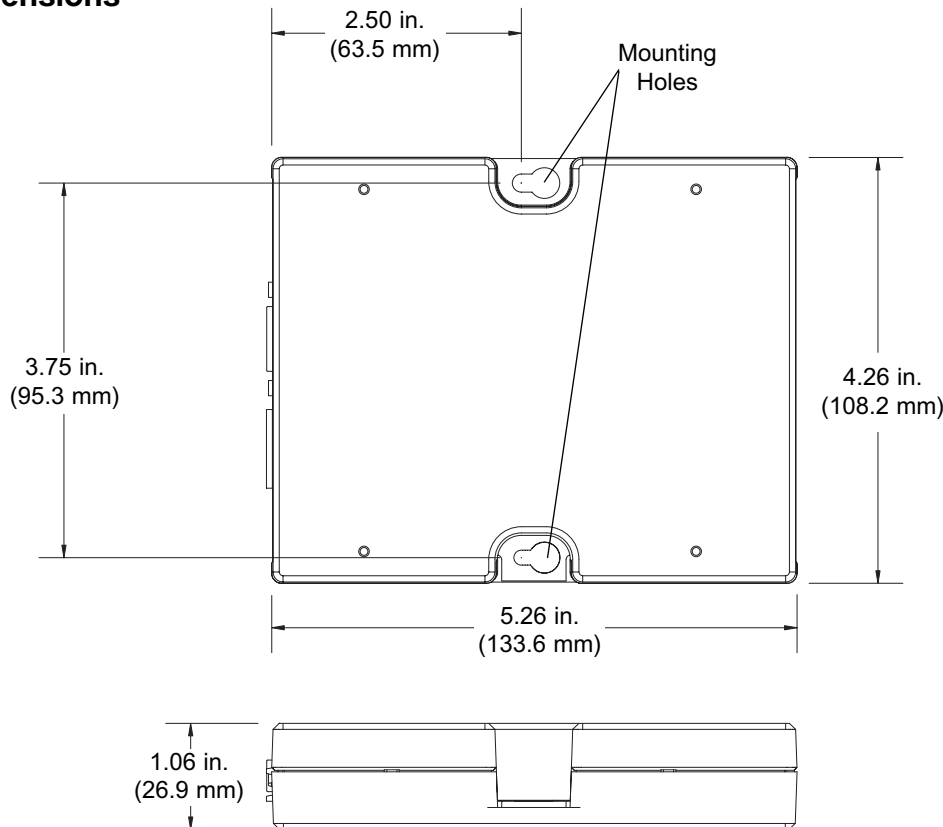

Low-Voltage PELV (Class 2: USA) Wiring

Important Notes

- Install in accordance with all applicable regulations.
- **CAUTION:** Do **not** connect line voltage/mains power to device. Improper wiring can result in personal injury or damage to the device or to other equipment.
- This control can use PELV (Class 2: USA) wiring methods. Check with your local electrical inspector for compliance with national and local codes and wiring practices.
- Make daisy-chain connections to the low-voltage PELV (Class 2: USA) Data Link terminals on the end of the Control Interface.
- Do not use T-taps. Run all wires in and out of the terminal block.
- Each terminal accepts up to two #18 AWG (1.0 mm²) wires.

Control Interface Wiring: GRX-3000 Control Unit

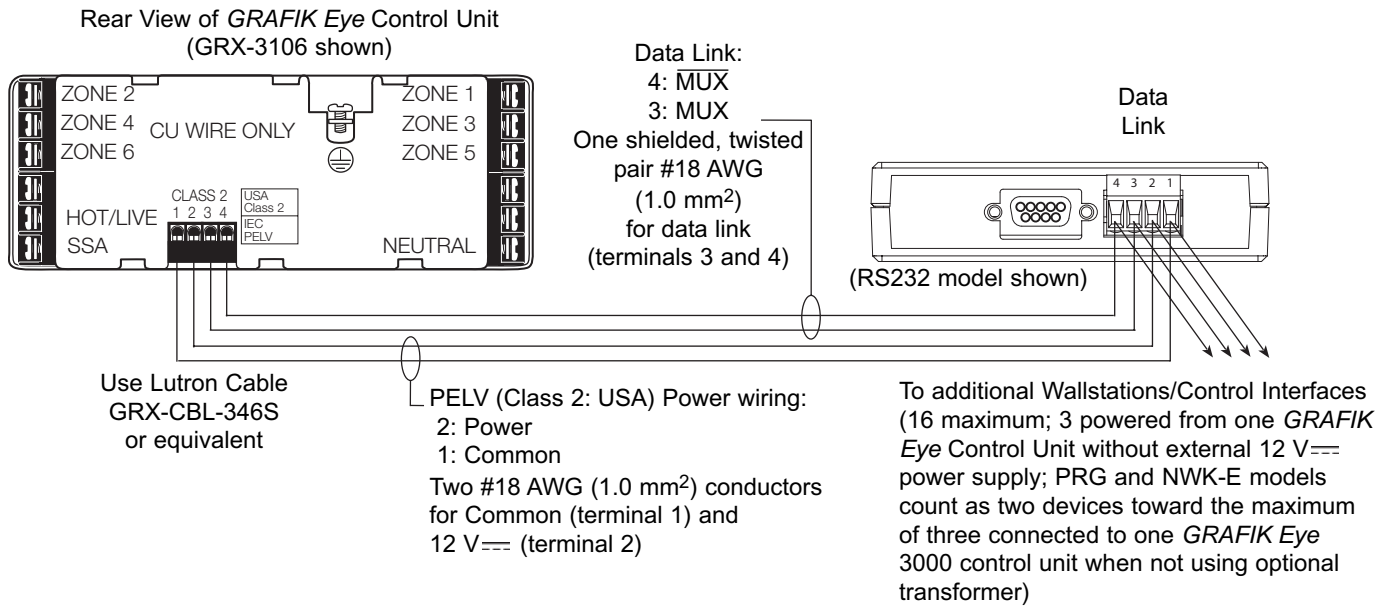

Control Interface Wiring: GRX-4000 Control Unit, OMX Control Station Device Link, or QS Link (Data Link connection shown)

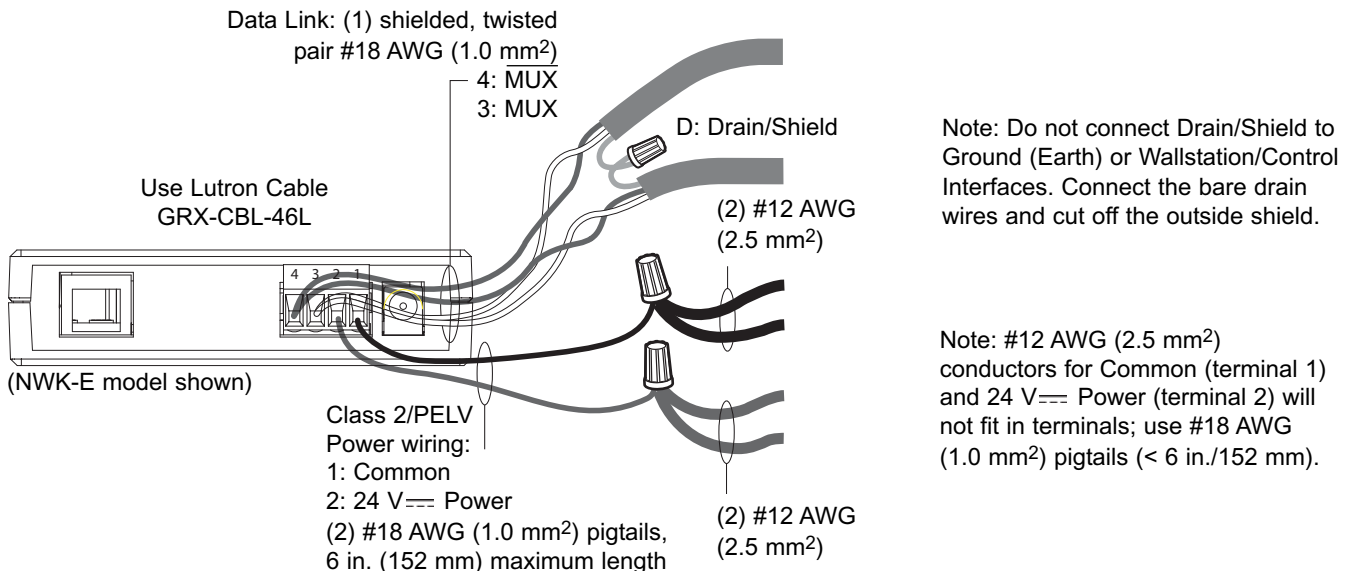

A/V Connections and Signal/Link Information

GRX-CI-NWK-E, GRX-IA-CI-NWK-E, OMX-CI-NWK-E

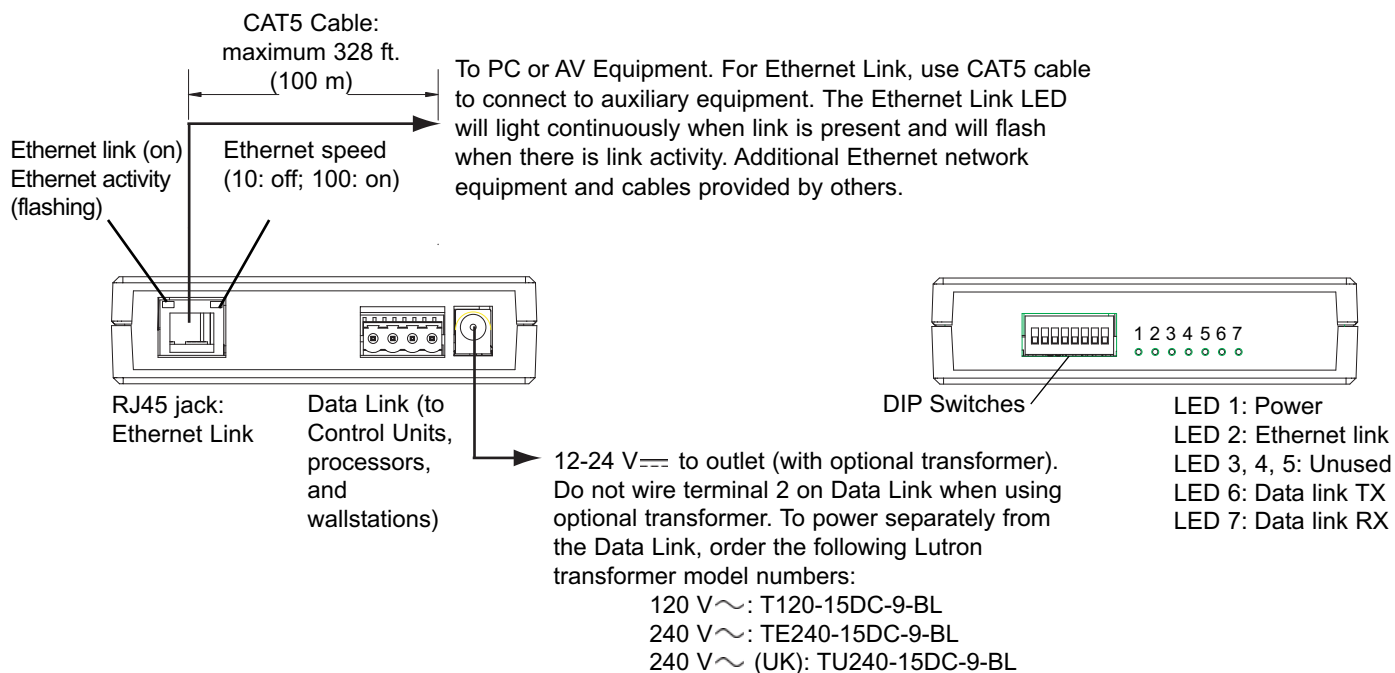

GRX-CI-RS232, GRX-IA-CI-RS232, OMX-CI-RS232

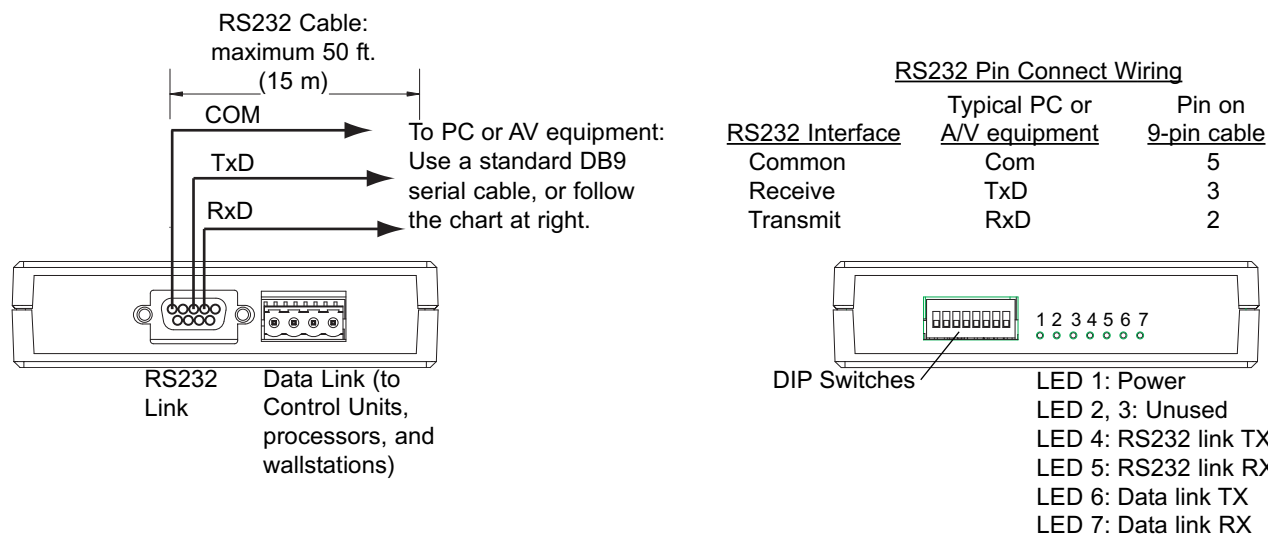

GRX-CI-PRG, GRX-IA-CI-PRG, QSE-CI-NWK-E

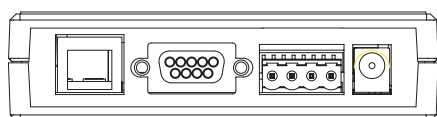

Links and connections are same as shown for above units.

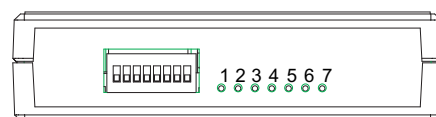

LED 1: Power
LED 2: Ethernet link
LED 3: Unused
LED 4: RS232 link TX
LED 5: RS232 link RX
LED 6: Data link TX
LED 7: Data link RX

Please refer to the enclosed CD for the product Specification Sheets and Operation Manuals, Ethernet Device IP program, and RS232 Protocol information.

Internet: www.lutron.com
E-mail: product@lutron.com

**World Headquarters
USA**

Lutron Electronics Co., Inc.
7200 Suter Road, Coopersburg, PA
18036-1299
TEL +1.610.282.3800
FAX +1.610.282.1243
Toll-Free 1.888.LUTRON1
Technical Support 1.800.523.9466

Brazil

Lutron BZ do Brasil Ltda.
AV, Brasil, 239, Jardim America
Sao Paulo-SP, CEP: 01431-000,
Brazil
TEL +55.11.3885.5152
FAX +55.11.3887.7138

North and South America

Technical Hotlines
USA, Canada, Caribbean:
1.800.523.9466
Mexico: +1.888.235.2910
Central/South America:
+1.610.282.6701

European Headquarters

United Kingdom
Lutron EA Ltd.
6 Sovereign Close, London, E1W 3JF
United Kingdom
TEL +44.(0)20.7702.0657
FAX +44.(0)20.7480.6899
FREEPHONE (UK) 0800.282.107
Technical support
+44.(0)20.7680.4481

France

Lutron LTC, S.A.R.L.
90 rue de Villiers, 92300
Levallois-Perret France
TEL +33.(0)1.41.05.42.80
FAX +33.(0)1.41.05.01.80
FREEPHONE 0800.90.12.18

Germany

Lutron Electronics GmbH,
Landsberger Allee 201, 13055
Berlin, Germany
TEL +49.(0)30.9710.4590
FAX +49.(0)30.9710.4591
FREEPHONE 00800.5887.6635

Italy

Lutron LDV, S.r.l.
FREEPHONE 800.979.208

Spain, Barcelona
Lutron CC, S.R.L.

Gran Via del Carlos III, 84, planta 3a,
08028, Barcelona, Spain
TEL +34.93.496.57.42
FAX +34.93.496.57.01
FREEPHONE 0900.948.944

Spain, Madrid

Lutron CC, S.R.L.
Calle Orense, 85, 28020
Madrid, Spain
TEL +34.91.567.84.79
FAX +34.91.567.84.78
FREEPHONE 0900.948.944

Asian Headquarters
Singapore

Lutron GL Ltd.
15 Hoe Chiang Road, #07-03 Euro
Asia Centre, Singapore 089316
TEL +65.6220.4666
FAX +65.6220.4333

China, Beijing

Lutron GL Ltd.
Beijing Representative Office
5th Floor, China Life Tower
No. 16 Chaowai Street, Chaoyang
District, Beijing 100020 China
TEL +86.10.5877.1817
FAX +86.10.5877.1816

China, Guangzhou

Lutron GL Ltd. Guangzhou
Representative Office
Suite A09, 23/F Tower A,
Centre Plaza
161 Lin He Xi Lu, Tian He District,
Guangzhou 510620 China
TEL +86.20.2885.8266
FAX +86.20.2885.8366

China, Shanghai

Lutron GL Ltd., Shanghai
Representative Office
Suite 07, 39th Floor, Plaza 66
1266 Nan Jing West Road,
Shanghai, 200040 China
TEL +86.21.6288.1473
FAX +86.21.6288.1751

China, Hong Kong

Lutron GL Ltd.
Unit 2808, 28/F,
248 Queen's Road East
Wanchai, Hong Kong
TEL +852.2104.7733
FAX +852.2104.7633

Japan

Lutron Asuka Co. Ltd.
No. 16 Kowa Building, 4F, 1-9-20
Akasaka, Minato-ku,
Tokyo 107-0052 Japan
TEL +81.3.5575.8411
FAX +81.3.5575.8420
FREEPHONE 0120.083.417

Asia Technical Hotlines

Northern China: 10.800.712.1536
Southern China: 10.800.120.1536
Hong Kong: 800.901.849
Indonesia: 001.803.011.3994
Japan: +81.3.5575.8411
Macau: 0800.401
Singapore: 800.120.4491
Taiwan: 00.801.137.737
Thailand: 001.800.120.665853
Other countries: +65.6220.4666

**Lutron Electronics Co., Inc.
One Year Limited Warranty**

For a period of one year from the date of purchase, and subject to the exclusions and restrictions described below, Lutron warrants each new unit to be free from manufacturing defects. Lutron will, at its option, either repair the defective unit or issue a credit equal to the purchase price of the defective unit to the Customer against the purchase price of comparable replacement part purchased from Lutron. Replacements for the unit provided by Lutron or, at its sole discretion, an approved vendor may be new, used, repaired, reconditioned, and/or made by a different manufacturer.

If the unit is commissioned by Lutron or a Lutron approved third party as part of a Lutron commissioned lighting control system, the term of this warranty will be extended, and any credits against the cost of replacement parts will be prorated, in accordance with the warranty issued with the commissioned system, except that the term of the unit's warranty term will be measured from the date of its commissioning.

EXCLUSIONS AND RESTRICTIONS

This Warranty does not cover, and Lutron and its suppliers are not responsible for:

1. Damage, malfunction or inoperability diagnosed by Lutron or a Lutron approved third party as caused by normal wear and tear, abuse, misuse, incorrect installation, neglect, accident, interference or environmental factors, such as (a) use of incorrect line voltages, fuses or circuit breakers; (b) failure to install, maintain and operate the unit pursuant to the operating instructions provided by Lutron and the applicable provisions of the National Electrical Code and of the Safety Standards of Underwriter's Laboratories; (c) use of incompatible devices or accessories; (d) improper or insufficient ventilation; (e) unauthorized repairs or adjustments; (f) vandalism; or (g) an act of God, such as fire, lightning, flooding, tornado, earthquake, hurricane or other problems beyond Lutron's control.
2. On-site labor costs to diagnose issues with, and to remove, repair, replace, adjust, reinstall and/or reprogram the unit or any of its components.
3. Equipment and parts external to the unit, including those sold or supplied by Lutron (which may be covered by a separate warranty).
4. The cost of repairing or replacing other property that is damaged when the unit does not work properly, even if the damage was caused by the unit.

EXCEPT AS EXPRESSLY PROVIDED IN THIS WARRANTY, THERE ARE NO EXPRESS OR IMPLIED WARRANTIES OF ANY TYPE, INCLUDING ANY IMPLIED WARRANTIES OF FITNESS FOR A PARTICULAR PURPOSE OR MERCHANTABILITY. LUTRON DOES NOT WARRANT THAT THE UNIT WILL OPERATE WITHOUT INTERRUPTION OR BE ERROR FREE.

NO LUTRON AGENT, EMPLOYEE OR REPRESENTATIVE HAS ANY AUTHORITY TO BIND LUTRON TO ANY AFFIRMATION, REPRESENTATION OR WARRANTY CONCERNING THE UNIT. UNLESS AN AFFIRMATION, REPRESENTATION OR WARRANTY MADE BY AN AGENT, EMPLOYEE OR REPRESENTATIVE IS SPECIFICALLY INCLUDED HEREIN, OR IN STANDARD PRINTED MATERIALS PROVIDED BY LUTRON, IT DOES NOT FORM A PART OF THE BASIS OF ANY BARGAIN BETWEEN LUTRON AND CUSTOMER AND WILL NOT IN ANY WAY BE ENFORCEABLE BY CUSTOMER.

IN NO EVENT WILL LUTRON OR ANY OTHER PARTY BE LIABLE FOR EXEMPLARY, CONSEQUENTIAL, INCIDENTAL OR SPECIAL DAMAGES (INCLUDING, BUT NOT LIMITED TO, DAMAGES FOR LOSS OF PROFITS, CONFIDENTIAL OR OTHER INFORMATION, OR PRIVACY; BUSINESS INTERRUPTION; PERSONAL INJURY; FAILURE TO MEET ANY DUTY, INCLUDING OF GOOD FAITH OR OF REASONABLE CARE; NEGLIGENCE, OR ANY OTHER PECUNIARY OR OTHER LOSS WHATSOEVER), NOR FOR ANY REPAIR WORK UNDERTAKEN WITHOUT LUTRON'S WRITTEN CONSENT ARISING OUT OF OR IN ANY WAY RELATED TO THE INSTALLATION, DEINSTALLATION, USE OF OR INABILITY TO USE THE UNIT OR OTHERWISE UNDER OR IN CONNECTION WITH ANY PROVISION OF THIS WARRANTY, OR ANY AGREEMENT INCORPORATING THIS WARRANTY, EVEN IN THE EVENT OF THE FAULT, TORT (INCLUDING NEGLIGENCE), STRICT LIABILITY, BREACH OF CONTRACT OR BREACH OF WARRANTY OF LUTRON OR ANY SUPPLIER, AND EVEN IF LUTRON OR ANY OTHER PARTY WAS ADVISED OF THE POSSIBILITY OF SUCH DAMAGES.

NOTWITHSTANDING ANY DAMAGES THAT CUSTOMER MIGHT INCUR FOR ANY REASON WHATSOEVER (INCLUDING, WITHOUT LIMITATION, ALL DIRECT DAMAGES AND ALL DAMAGES LISTED ABOVE), THE ENTIRE LIABILITY OF LUTRON AND OF ALL OTHER PARTIES UNDER THIS WARRANTY ON ANY CLAIM FOR DAMAGES ARISING OUT OF OR IN CONNECTION WITH THE MANUFACTURE, SALE, INSTALLATION, DELIVERY, USE, REPAIR, OR REPLACEMENT OF THE UNIT, OR ANY AGREEMENT INCORPORATING THIS WARRANTY, AND CUSTOMER'S SOLE REMEDY FOR THE FOREGOING, WILL BE LIMITED TO THE AMOUNT PAID TO LUTRON BY CUSTOMER FOR THE UNIT. THE FOREGOING LIMITATIONS, EXCLUSIONS AND DISCLAIMERS WILL APPLY TO THE MAXIMUM EXTENT ALLOWED BY APPLICABLE LAW, EVEN IF ANY REMEDY FAILS ITS ESSENTIAL PURPOSE.

TO MAKE A WARRANTY CLAIM

To make a warranty claim, promptly notify Lutron within the warranty period described above by calling the Lutron Technical Support Center at (800) 523-9466. Lutron, in its sole discretion, will determine what action, if any, is required under this warranty. To better enable Lutron to address a warranty claim, have the unit's serial and model numbers available when making the call. If Lutron, in its sole discretion, determines that an on-site visit or other remedial action is necessary, Lutron may send a Lutron Services Co. representative or coordinate the dispatch of a representative from a Lutron approved vendor to Customer's site, and/or coordinate a warranty service call between Customer and a Lutron approved vendor.

This warranty gives you specific legal rights, and you may also have other rights which vary from state to state. Some states do not allow limitations on how long an implied warranty lasts, so the above limitation may not apply to you. Some states do not allow the exclusion or limitation of incidental or consequential damages, so the above limitation or exclusion may not apply to you.

Lutron, the sunburst logo, and GRAFIK Eye are registered trademarks and Architrave is a trademark of Lutron Electronics Co., Inc.

© 2008 Lutron Electronics Co., Inc.



Lutron Electronics Co., Inc.
Made and printed in U.S.A. 1/08
P/N 040-242 Rev. A



Contents

General Information

Communication Settings	4
LEDs and Wiring Terminals	5
RS232 Wiring.....	5
Ethernet Wiring	5
Serial ID Numbers	5
String Format.....	6
String Types	6
Startup Response Information	7

Strings

Device Strings	8
Device String Format Explanations	8
Set a Scene # on a <i>GRAFIK Eye QS</i>	9
Query the Current Scene # on a <i>GRAFIK Eye QS</i>	9
Query the Current Scene # on Each <i>GRAFIK Eye QS</i> in the System	9
Set Zone Lock on a <i>GRAFIK Eye QS</i>	10
Set Scene Lock on a <i>GRAFIK Eye QS</i>	10
Start/Stop Sequencing on a <i>GRAFIK Eye QS</i>	10
Start a Master Raise of All Lighting Zones on a <i>GRAFIK Eye QS</i>	11
Start a Master Lower of All Lighting Zones on a <i>GRAFIK Eye QS</i>	11
Stop a Master Raise or Lower of All Lighting Zones on a <i>GRAFIK Eye QS</i>	11
Set a Zone Level on a <i>GRAFIK Eye QS</i>	12
Query the Zone Level on a <i>GRAFIK Eye QS</i>	12
Query the Level of All Zones on a <i>GRAFIK Eye QS</i>	12
Set the Shade Position of a <i>Sivoia QS</i>	13
Query the Shade Position of a <i>Sivoia QS</i>	13
Simulate a Button Press	14
Simulate a Button Release	14

Contents (continued)

Monitoring Strings	15
Monitoring String Format.....	15
Enable/Disable Diagnostic Monitoring.....	15
Query Status of Diagnostic Monitoring	15
Enable/Disable Event Monitoring.....	16
Query Status of Event Monitoring	16
Enable/Disable Button Monitoring.....	16
Query Status of Button Monitoring.....	16
Enable/Disable Zone Monitoring	17
Query Status of Zone Monitoring	17
Enable/Disable Scene Monitoring	17
Query Status of Scene Monitoring	17
Enable/Disable Reply State	18
Query Status of Reply State	18
Enable/Disable Prompt.....	18
Query Status of Prompt.....	18
Enable/Disable All Monitoring.....	19
Query Status of All Monitoring	19
Ethernet Configuration Strings	20
Set IP Address.....	20
Get IP Address.....	20
Set Gateway Address	20
Get Gateway Address.....	20
Set Subnet Mask	21
Get Subnet Mask.....	21
Change Login Information	21
Get Login Information	21
Reset Strings	22
Restart the Device	22
Restore to Factory Defaults.....	22
Save Strings	22
Save	22

Contents (continued)

Style Strings	23
Enable/Disable Hexadecimal Readout of Zones	23
Query Status of Hexadecimal Readout of Zones.....	23
Enable/Disable Custom Names.....	23
Query Status of Custom Names.....	23
Enable/Disable Extra Precision.....	24
Query Status of Extra Precision	24
Enable/Disable Expanded Prompt.....	24
Query Status of Expanded Prompt	24
Query Status of All Styles.....	25
Name Strings.....	26
Name a Device.....	26
Get Name from ID.....	27
Details Strings	27
Get Details from Device.....	27
Error Response Strings	28
Error String Format	28
Appendix A: <i>GRAFIK Eye</i> QS Component List	29
Appendix A: <i>GRAFIK Eye</i> QS Component List (Shade Information)	30
Appendix A: <i>GRAFIK Eye</i> QS Component List (Component Numbers for <i>SeeTouch</i> QS Keypad Buttons)	31
Appendix B: Component Actions and Parameters	32

General Information

This document describes the strings available to set up, monitor, and operate the QSE-CI-NWK-E interface. The QSE-CI-NWK-E is a device that allows you to connect a PC or AV equipment to a QS system via Ethernet or RS232. A string is a set of specifically worded parameters that send, request, or return information to and from the QSE-CI-NWK-E.

To work properly, the system the QSE-CI-NWK-E is installed in must have the following minimum software code versions:

- Shade code rev. 1A or later
- QSG code revision 1.7 or later
- Keypad code revision 1.7 or later

COMMUNICATION SETTINGS

RS232 Settings

To configure your device to talk to the QSE-CI-NWK-E Interface, use the data conventions listed below.

- 9600/19200/38400/115200 BAUD
- 8 DATA
- 1 STOP
- NO PARITY
- NO FLOW CONTROL

If you wish to send these commands from a PC, run Microsoft Windows® Hyper Terminal or an equivalent program. Then, select Local Echo, Line Feed, and Carriage Return inbound and outbound. This allows you to see the characters that you are typing as well as keep the responses from overwriting typed characters. Refer to the table below for dipswitch settings to select baud rates.

BAUD	DIP SWITCH 7	DIP SWITCH 8
9600	ON	OFF
19200	OFF	ON
38400	ON	ON
115200	OFF	OFF

Ethernet Settings

To configure your device to talk to a QSE-CI-NWK-E, open a Telnet session with the following default IP address, port, and login information.

ATTRIBUTE	DEFAULT VALUE
Default IP Address	192.168.250.1
Default Subnet Mask	255.255.255.0
Default Port	23 (Telnet Port)
Default Login for Connection 1	'nwk'
Default Login for Connection 2	'nwk2'

If you wish to send these commands from a PC, run the Microsoft Windows® Telnet program or an equivalent program. In most situations, the IP address should be the same as the PC to which it is connected, except for the last digit (e.g., 192.168.250.x, where x is not equal to 1), and the subnet mask is 255.255.255.0. The Ethernet device information may also be managed using Lutron's DeviceIP software program, which can be found on the enclosed CD.

LEDS AND WIRING TERMINALS

PELV (Class 2: USA) Wiring

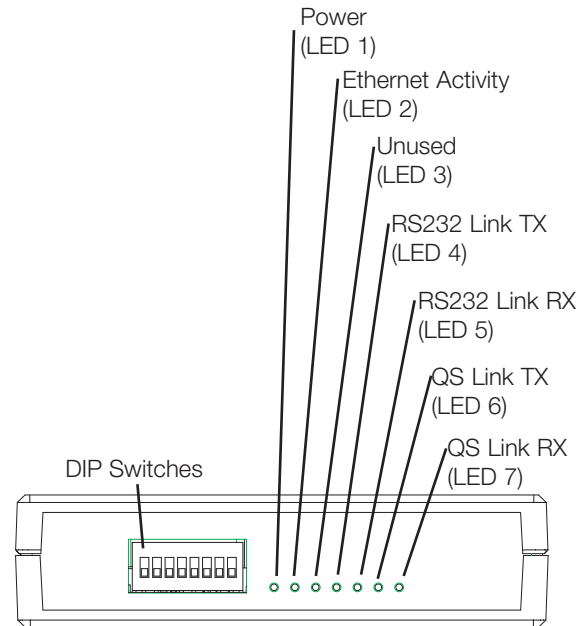
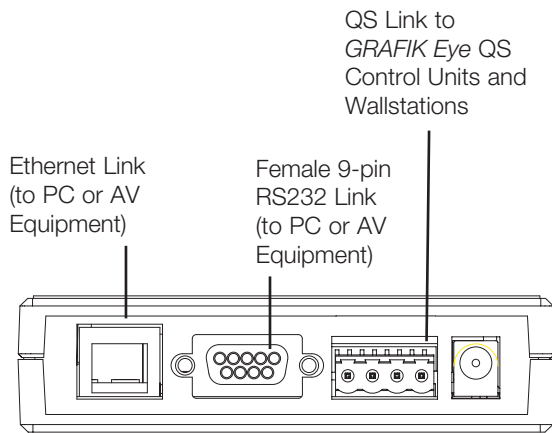

RS232 WIRING

For connection to any GRAFIK Eye QS RS232 Interface, use a DB9 RS232 cable. If you do not have this cable, the following table lists the connections you need to make one.

TYPICAL PC OR AV EQUIPMENT SIGNAL	PIN ON STANDARD 9-PIN CONNECTOR OR QSE	PIN ON STANDARD 25-PIN CONNECTOR
COM	5	7
TxD	3	2
RxD	2	3

ETHERNET WIRING

Wire out of the Ethernet port to PC or AV Equipment using CAT5 cable (maximum 328 feet/100 m) to connect to auxiliary equipment. The Ethernet Activity LED will light continuously when link is present and will flash when there is link activity. Ethernet network equipment and cables provided by third party vendors.

SERIAL ID NUMBERS

The QS link supports a maximum of 100 devices. Each device has a unique factory-assigned 8-character serial ID number. This serial ID number cannot be changed and is used to address the device on the link. The serial ID number appears on a label on each QS device.

When the serial ID number is used in any string (for example, DEVICE strings), it must be preceded by "0x", which is the prefix preceding all hexadecimal numbers. (See String Format on the next page.) See the specific string examples for exact syntax.

STRING FORMAT

- All strings are in ASCII characters
- Each string is made up of fields separated by commas and terminated with a carriage return (<CR> = 0Dh)
- Strings are not case sensitive
- Starting and trailing spaces will be ignored
- Hexadecimal values must be preceded by "0x".

STRING TYPES

The QSE supports the following command, query, and response strings:

- Device
- Ready
- Monitoring
- Ethernet
- Reset
- Save
- Style
- Name
- Details
- Error

There are four string types that can be sent or received by the interface: Commands, Queries, Responses, and Events. Each type of data will have a prefix to identify it. The prefix-identifiers are detailed below.

PREFIX	TYPE	DESCRIPTION
#	COMMAND	Command is sent to and interpreted by the processor via an integration point (RS232 or Ethernet)
?	QUERY	A request for the status of a part of the system
~	RESPONSE	Response from QSE after a Query, Command or Event
~	EVENT	An event is a result of a system change independent of the QSE-CI-NWK-E. For example, a user button press or a timeclock-initiated scene # change would produce an ~EVENT string
~	ERROR	Errors in syntax will generate an ~ERROR response (see Error).
;	COMMENT	A string to be ignored by the QSE. If used within a line (after a command or query), everything including and after the ';' will be ignored.

Response Notes

For all strings except the DEVICE command:

- When a command is sent, the response will return a confirmation of the command that mimics the command sent
- When a query is sent, the response returns the information requested
- When a query is sent that requests "all" information, the response returns a list of the information requested for each device, setting, or other component; each response is on its own line

For the DEVICE command:

- If setting the scene # or the level, the response will return a confirmation of the command that mimics the command sent
- If the scene # or level changes, or there is a button event or button press/release, the QSE will generate a response reflecting the new state
- If setting a sequence, the response returns for each new scene #, as above
- If setting zone lock or scene lock, no response is generated
- If sending a master raise or master lower, a response is generated periodically (approximately every 10 seconds)

STARTUP RESPONSE INFORMATION

When connected to power, the QSE-CI-NWK-E polls all the devices on the link for their names, and reads the zone and scene information for all *GRAFIK Eye* QS devices on the link. The device scene and zone information will generate ~DEVICE responses on power up.

The QSE-CI-NWK-E will generate a ~NAME response on startup only if the device name stored in the remote device differs from the name stored on the QSE-CI-NWK-E. The names are stored to the other devices when a NAME command is issued. It is important to note that these responses occur only on power up and do not occur upon connection to the QSE. These outputs may be turned on or off by setting or clearing the appropriate monitoring flags.

Please allow 10 seconds on startup for the QSE-CI-NWK-E to fully boot or restore power prior to sending commands.

Device Strings

Device integration strings allow the user to access components of the QS system. The user can read current scene and zone information through the ?DEVICE query, and can set the level of a light, the position of a shade, or the scene number of a *GRAFIK Eye* lighting controller through the #DEVICE command. Real-time device monitoring is set up through the #MONITORING command set, and then generates responses using the ~DEVICE format. Devices may be referred to by their serial ID numbers, or may be named and then referred to by that name. The custom name flag in the Style options only effects responses; for commands and queries, either the name or serial ID number may be used.

Queries with multiple responses (for multiple components and/or multiple devices) will generate responses on multiple lines.

DEVICE STRING FORMAT EXPLANATIONS

String prefixes:

#	sending a command to the QS system
?	sending a query to the QS system
~	getting a response or status change from the QS system

Serial ID number:

Set at the factory for every device. Each one is a hexadecimal number made up of 8 ascii characteres preceded by '0x'. They are case insensitive ('a' = 'A').

Examples: 0x000B18432 for serial ID number 0000B18432
0xFFFFFFFF for all devices

Component:

The component number specifies the feature of the device. Component numbers vary by device and are listed in Appendix A. Or, use the examples in the DEVICE section.

Action:

The action to perform on the component. For example, if the component number is a zone, the action might be 'set level'. The actions are listed in appendix B.

Parameters:

Parameters for the action. For example, if the action is 'set level', the first parameter is a level percentage and the second parameter is a fade time. Parameters are listed with the actions in Appendix B.

Device Strings (continued)

SET A SCENE # ON A GRAFIK EYE QS	
Syntax	#DEVICE,<ID>,141,7,<scene #><CR>
ID	See DEVICE string format
141	Component = the scene controller of the <i>GRAFIK Eye QS</i> (See Appendix A for a list of Components)
7	Action = set the active scene # (See Appendix B for a list of Component Actions)
scene #	Tells the component which scene # to set Allowed values: 0 - 16 (0 is Off scene)
Example	Set the <i>GRAFIK Eye QS</i> with the serial ID number 00AC123D to scene # 1 #DEVICE,0x00AC123D,141,7,1<CR>

QUERY THE CURRENT SCENE # ON A GRAFIK EYE QS	
Syntax	?DEVICE,<ID>,141,7<CR>
ID	See DEVICE string format
141	Component = the scene controller of the <i>GRAFIK Eye QS</i> (See Appendix A for a list of Components)
7	Action = get the active scene # (See Appendix B for a list of Component Actions)
Example	Query the <i>GRAFIK Eye QS</i> with the serial ID number 00AC123D for its current scene # ?DEVICE,0x00AC123D,141,7<CR> Response to query shows that the <i>GRAFIK Eye QS</i> is in scene #4 ~DEVICE,0x00AC123D,141,7,4

QUERY THE CURRENT SCENE # ON EACH GRAFIK EYE QS IN THE SYSTEM	
Syntax	?DEVICE,ALL_DEVICES,141,7<CR>
ALL_DEVICES	All <i>GRAFIK Eye QS</i> control units on the link
141	Component = the scene controller of the <i>GRAFIK Eye QS</i> (See Appendix A for a list of Components)
7	Action = get the active scene # (See Appendix B for a list of Component Actions)
Example	Query each <i>GRAFIK Eye QS</i> on the system for its current scene # ?DEVICE,ALL_DEVICES,141,7<CR> Response to query shows the current scene # of all <i>GRAFIK Eye QS</i> control units, in order by serial ID number. Each QS control unit's status is displayed on a separate line, with the current scene # displayed as the last number in the string. ~DEVICE,0x00AC123D,141,7,4 ~DEVICE,0x00AC226A,141,7,8 ~DEVICE,0x00AC709B,141,7,0

Device Strings (continued)

SET ZONE LOCK ON A GRAFIK EYE QS	
Syntax	#DEVICE,<ID>,141,15,<value><CR>
ID	See DEVICE string format
141	Component = the scene controller of the <i>GRAFIK Eye QS</i> (See Appendix A for a list of Components)
15	Action = set the zone lock to On or Off (See Appendix B for a list of Component Actions)
value	0 = zone lock Off 1 = zone lock On When zone lock is On, zone levels cannot be saved on the <i>GRAFIK Eye QS</i> in normal mode
Example	Set the <i>GRAFIK Eye QS</i> with the serial ID number 00AC123D to turn zone lock On #DEVICE,0x00AC123D,141,15,1<CR>

SET SCENE LOCK ON A GRAFIK EYE QS	
Syntax	#DEVICE,<ID>,141,16,<value><CR>
ID	See DEVICE string format
141	Component = the scene controller of the <i>GRAFIK Eye QS</i> (See Appendix A for a list of Components)
16	Action = set the scene lock to On or Off (See Appendix B for a list of Component Actions)
value	0 = scene lock Off 1 = scene lock On When scene lock is On, scene #s cannot be changed from the <i>GRAFIK Eye QS</i> or from keypads programmed to it during normal operation
Example	Set the <i>GRAFIK Eye QS</i> with the serial ID number 00AC123D to turn scene lock Off #DEVICE,0x00AC123D,141,16,0<CR>

START/STOP SEQUENCING ON A GRAFIK EYE QS	
Syntax	#DEVICE,<ID>,141,17,<value><CR>
ID	See DEVICE string format
141	Component = the scene controller of the <i>GRAFIK Eye QS</i> (See Appendix A for a list of Components)
17	Action = set the status of sequencing between scene #s (See Appendix B for a list of Component Actions)
value	0 = sequencing off; current sequencing stops 1 = sequencing on; scene #s 1 to 4 sequence and repeat 2 = sequencing on; scene #s 5 to 16 sequence and repeat
Example	Set the <i>GRAFIK Eye QS</i> with the serial ID number 00AC123D to sequence scene #s 5 through 16 #DEVICE,0x00AC123D,141,17,2<CR>

Device Strings (continued)

START A MASTER RAISE OF ALL LIGHTING ZONES ON A GRAFIK EYE QS	
Syntax	#DEVICE,<ID>,141,18<CR>
ID	See DEVICE string format
141	Component = the scene controller of the <i>GRAFIK Eye QS</i> (See Appendix A for a list of Components)
18	Action = raise the level of all lighting zones (See Appendix B for a list of Component Actions)
Example	Set the <i>GRAFIK Eye QS</i> with the serial ID number 00AC123D to start raising all lighting zones #DEVICE,0x00AC123D,141,18<CR>
Additional Information	Follow this command with STOP A MASTER RAISE/LOWER. If none is issued, lights will go to 100% (Full On).

START A MASTER LOWER OF ALL LIGHTING ZONES ON A GRAFIK EYE QS	
Syntax	#DEVICE,<ID>,141,19<CR>
ID	See DEVICE string format
141	Component = the scene controller of the <i>GRAFIK Eye QS</i> (See Appendix A for a list of Components)
19	Action = lower the level of all lighting zones (See Appendix B for a list of Component Actions)
Example	Set the <i>GRAFIK Eye QS</i> with the serial ID number 00AC123D to start lowering all lighting zones #DEVICE,0x00AC123D,141,19<CR>
Additional Information	Follow this command with STOP A MASTER RAISE/LOWER. If none is issued, lights will go to 0% (Off).

STOP A MASTER RAISE OR LOWER OF ALL LIGHTING ZONES ON A GRAFIK EYE QS	
Syntax	#DEVICE,<ID>,141,20<CR>
ID	See DEVICE string format
141	Component = the scene controller of the <i>GRAFIK Eye QS</i> (See Appendix A for a list of Components)
20	Action = stop raising or lowering the level of all lighting zones (See Appendix B for a list of Component Actions)
Example	Set the <i>GRAFIK Eye QS</i> with the serial ID number 00AC123D to stop raising or lowering all lighting zones #DEVICE,0x00AC123D,141,20<CR>

Device Strings (continued)

SET A ZONE LEVEL ON A GRAFIK EYE QS	
Syntax	#DEVICE,<ID>,<zone>,14,<level>,<fade><CR>
ID	See DEVICE string format
zone	Tells the component which zone to set Allowed values: 1 - 6
14	Action = fade a zone to a specified level (See Appendix B for a list of Component Actions)
level	Tells the component what intensity to go to Allowed values: 0 to 100, or 0.00 to 100.00, or 0x0000h to 0xFFFFh
fade	Specifies the time the light takes to arrive at the level Format: Seconds; Minutes:Seconds; Hours:Minutes:Seconds
Example	Set the <i>GRAFIK Eye QS</i> with the serial ID number 00AC123D to fade zone 2 to 36% over 1 minute and 30 seconds. #DEVICE,0x00AC123D,2,14,36,1:30<CR>

QUERY THE ZONE LEVEL ON A GRAFIK EYE QS	
Syntax	?DEVICE,<ID>,<zone>,14<CR>
ID	See DEVICE string format
zone	Tells the component which zone to query Allowed values: 1 - 6
14	Action = get the zone target level (the level the zone is currently or is fading to) (See Appendix B for a list of Component Actions)
Example	Query the <i>GRAFIK Eye QS</i> with the serial ID number 00AC123D for the current level of zone 4. ?DEVICE,0x00AC123D,4,14<CR> Response to query shows that zone 4 of the <i>GRAFIK Eye QS</i> is at or going to 52% ~DEVICE,0x00AC123D,4,14,52

QUERY THE LEVEL OF ALL ZONES ON A GRAFIK EYE QS	
Syntax	?DEVICE,<ID>,0,14<CR>
ID	See DEVICE string format
0	All zones on the <i>GRAFIK Eye QS</i>
14	Action = get the zone level (See Appendix B for a list of Component Actions)
Example	Query the <i>GRAFIK Eye QS</i> with the serial ID number 00AC123D for the target level of all zones ?DEVICE,0x00AC123D,0,14<CR> Response to query shows the target level of all zones. Each zone is displayed on a separate line, with the target level (percentage) displayed as the last number in the string. ~DEVICE,0x00AC123D,1,14,52 ~DEVICE,0x00AC123D,2,14,75 ~DEVICE,0x00AC123D,3,14,0 ~DEVICE,0x00AC123D,4,14,33 ~DEVICE,0x00AC123D,5,14,65 ~DEVICE,0x00AC123D,6,14,0

Device Strings (continued)

SET THE SHADE POSITION OF A SIVOIA® QS	
Syntax	#DEVICE,<ID>,0,14,<level>,<fade><CR>
ID	See DEVICE string format
0	Component = <i>Sivoia</i> QS shade
14	Action = set the position of a <i>Sivoia</i> QS shade (See Appendix B for a list of Component Actions)
level	Tells the shade what position to go to Allowed values: 0 to 100, or 0.00 to 100.00, or 0x0000h to 0xFFFFh 0 = fully open 100 = fully closed
fade	0 is the only allowed value for <i>Sivoia</i> QS shades
Example	Set the <i>Sivoia</i> QS with the serial ID number 00BD423D to 36.6% open #DEVICE,0x00BD423D,0,14,36.6,0<CR>

QUERY THE SHADE POSITION OF A SIVOIA QS	
Syntax	?DEVICE,<ID>,0,14<CR>
ID	See DEVICE string format
0	Component = <i>Sivoia</i> QS shade (See Appendix B for a list of Component Actions)
14	Action = get the target position of a <i>Sivoia</i> QS shade (the position of a stopped shade, or the final destination of a moving shade relative to open)
Example	Query the <i>Sivoia</i> QS with the serial ID number 00BD423D for its target shade position ?DEVICE,0x00BD423D,0,14<CR> Response to the query shows that the <i>Sivoia</i> QS with ID 00BD423D is 23.12% open. ~DEVICE, 00BD423D,0,14,23.12

Device Strings (continued)

SIMULATE A BUTTON PRESS	
Syntax	#DEVICE,<ID>,<button>,3<CR>
ID	See DEVICE string format
button	Specify the button number (see Appendix A)
3	Action = simulate a button press This produces the action the actual button is programmed to perform (See Appendix B for a list of Component Actions)
Example	Simulate a button press on the top scene # button of a <i>GRAFIK Eye QS</i> with the serial ID number 00AC123D #DEVICE,0x00AC123D,70,3<CR>

SIMULATE A BUTTON RELEASE	
Syntax	#DEVICE,<ID>,<button>,4<CR>
ID	See DEVICE string format
button	Specify the button number (see Appendix A)
4	Action = simulate a button release This stops the action the actual button is programmed to perform (See Appendix B for a list of Component Actions)
Example	Simulate a button release on the first zone lower button of a <i>GRAFIK Eye QS</i> with the serial ID number 00AC123D. This stops that zone from fading, raising, or lowering. #DEVICE,0x00AC123D,37,4<CR>

Monitoring Strings

Monitoring allows the user to determine what types of messages the system will report. Values are automatically saved. The user can temporarily change settings to hide or show information as desired.

When enabled, the zone, scene #, and property monitoring generate a ~DEVICE response for each system change that occurs. (See the ~DEVICE response for details.) Queries for all monitoring (255) will respond with one ~MONITORING response per monitoring type.

MONITORING STRING FORMAT (SPECIFIC EXAMPLES FOLLOW)	
Syntax	<type>MONITORING,<monitoring type>,<action><CR>
type	# command into the QS system ? query to the QS system ~ response from the QS system or event change from the QS system
monitoring type	1 = diagnostic 2 = event (zone, button, and scene # combined) 3 = button 5 = zone 8 = scene # 11 = reply state 12 = prompt state 13 = name response (when a device name changes) 255 = all monitoring
action	1 = enabled 2 = disabled
Example	Enable monitoring of zone events on link monitoring type (zone) = 5 action (enable) = 1 #MONITORING,5,1<CR>

ENABLE/DISABLE DIAGNOSTIC MONITORING	
Syntax	#MONITORING,1,<action><CR>
1	Monitoring type = diagnostic monitoring ~ERROR responses for bad commands (On by default)
action	1 = enabled 2 = disabled
Example	Enable diagnostic monitoring on link #MONITORING,1,1<CR>

QUERY STATUS OF DIAGNOSTIC MONITORING	
Syntax	?MONITORING,1,<action><CR>
1	Monitoring type = diagnostic monitoring ~ERROR responses for bad commands (On by default)
Example	Query the QS system to check if diagnostic monitoring is enabled ?MONITORING,1<CR> Response (if enabled): ~MONITORING,1,1<CR>

Monitoring Strings (continued)

ENABLE/DISABLE EVENT MONITORING	
Syntax	#MONITORING,2,<action><CR>
2	Monitoring type = event monitoring ~DEVICE responses changes in state (On by default)
action	1 = enabled 2 = disabled
Example	Disable event monitoring on link #MONITORING,2,2<CR>

QUERY STATUS OF EVENT MONITORING	
Syntax	?MONITORING,2<CR>
2	Monitoring type = event monitoring ~DEVICE responses changes in state (On by default)
Example	Query the QS system to check if event monitoring is enabled ?MONITORING,2<CR> Response (if disabled): ~MONITORING,2,2<CR>

ENABLE/DISABLE BUTTON MONITORING	
Syntax	#MONITORING,3,<action><CR>
3	Monitoring type = button monitoring ~DEVICE responses for button changes
action	1 = enabled 2 = disabled
Example	Enable button monitoring on link #MONITORING,3,1<CR>

QUERY STATUS OF BUTTON MONITORING	
Syntax	?MONITORING,3<CR>
3	Monitoring type = button monitoring ~DEVICE responses for button changes
Example	Query the QS system to check if button monitoring is enabled ?MONITORING,3<CR> Response (if enabled): ~MONITORING,3,1<CR>

Monitoring Strings (continued)

ENABLE/DISABLE ZONE MONITORING	
Syntax	#MONITORING,5,<action><CR>
5	Monitoring type = zone monitoring ~DEVICE responses for zone target changes for lights and shades
action	1 = enabled 2 = disabled
Example	Enable zone monitoring on link #MONITORING,5,1<CR>

QUERY STATUS OF ZONE MONITORING	
Syntax	?MONITORING,5<CR>
5	Monitoring type = zone monitoring ~DEVICE responses for zone target changes
Example	Query the QS system to check if zone monitoring is enabled ?MONITORING,5<CR> Response (if enabled): ~MONITORING,5,1<CR>

ENABLE/DISABLE SCENE MONITORING	
Syntax	#MONITORING,8,<action><CR>
8	Monitoring type = scene monitoring ~DEVICE responses for scene changes
action	1 = enabled 2 = disabled
Example	Enable scene monitoring on link #MONITORING,8,1<CR>

QUERY STATUS OF SCENE MONITORING	
Syntax	?MONITORING,8,<action><CR>
8	Monitoring type = scene monitoring ~DEVICE responses for scene changes
Example	Query the QS system to check if scene monitoring is enabled ?MONITORING,8<CR> Response (if enabled): ~MONITORING,8,1<CR>

Monitoring Strings (continued)

ENABLE/DISABLE REPLY STATE	
Syntax	#MONITORING,11,<action><CR>
11	Monitoring type = reply state When set, the QSE generates responses (On by default)
action	1 = enabled 2 = disabled
Example	Enable reply state generation on link #MONITORING,11,1<CR>

QUERY STATUS OF REPLY STATE	
Syntax	?MONITORING,11,<action><CR>
11	Monitoring type = reply state When set, the QSE generates responses (On by default)
Example	Query the QS system to check if reply state is enabled ?MONITORING,11<CR> Response (if enabled): ~MONITORING,11,1<CR>

ENABLE/DISABLE PROMPT	
Syntax	#MONITORING,12,<action><CR>
12	Monitoring type = prompt Displays a QSE> prompt when ready for a command
action	1 = enabled 2 = disabled
Example	Enable prompt #MONITORING,12,1<CR> QSE> Disable prompt #MONITORING,12,2<CR>

QUERY STATUS OF PROMPT	
Syntax	?MONITORING,12<CR>
12	Monitoring type = prompt Displays a QSE> prompt when ready for a command
Example	Query the QS system to check if prompt is enabled ?MONITORING,12<CR> Response (if enabled): ~MONITORING,12,1<CR>

Monitoring Strings (continued)

ENABLE/DISABLE ALL MONITORING	
Syntax	#MONITORING,255,<action><CR>
255	Monitoring type = All monitoring (except prompt and reply state) Turns on all the monitoring options at the same time. Reply and Prompt must be turned on separately.
action	1 = enabled 2 = disabled
Example	Enable all monitoring (except Reply and Prompt) on link #MONITORING,255,1<CR>

QUERY STATUS OF ALL MONITORING	
Syntax	?MONITORING,255<CR>
255	Monitoring type = All monitoring (including prompt and reply state) Checks the status of all the monitoring options at the same time.
Example	Query the QS system to check the status of all monitoring (enabled or disabled) ?MONITORING,255<CR> Sample Response Strings ~MONITORING,1,2 Diagnostic monitoring is disabled ~MONITORING,2,1 Event monitoring is enabled ~MONITORING,3,1 Button monitoring is enabled ~MONITORING,5,1 Zone monitoring is enabled ~MONITORING,8,2 Scene monitoring is disabled ~MONITORING,11,1 Reply is enabled ~MONITORING,12,2 Prompt is disabled ~MONITORING,13,1 Name response is enabled

Ethernet Configuration Strings

Ethernet commands set up the Telnet connection. These settings may be changed over RS232 or Ethernet. The device must be power cycled (or reset with the #RESET command) before the changes take effect. See the Ethernet Settings section of General Information for more information.

SET IP ADDRESS	
Syntax	#ETHERNET,0,<address><CR>
0	Set IP address
<address>	xxx.xxx.xxx.xxx
Example	Set IP address to 192.168.250.1 #ETHERNET,0,192.168.250.1<CR>

GET IP ADDRESS	
Syntax	?ETHERNET,0<CR>
0	Get IP address
Example	Query the QS system for the IP address ?ETHERNET,0<CR> Response for the IP address: ~ETHERNET,0,192.168.250.1<CR>

SET GATEWAY ADDRESS	
Syntax	#ETHERNET,1,<address><CR>
1	Set gateway address
<address>	xxx.xxx.xxx.xxx
Example	Set gateway address to 10.2.4.1 #ETHERNET,1,192.168.250.1<CR>

GET GATEWAY ADDRESS	
Syntax	?ETHERNET,1<CR>
1	Get gateway address
Example	Query the QS system for the gateway address ?ETHERNET,1<CR> Response for the gateway: ~ETHERNET,1,192.168.250.1<CR>

Ethernet Strings (continued)

SET SUBNET MASK	
Syntax	#ETHERNET,2,<address><CR>
2	Set subnet mask
<address>	xxx.xxx.xxx.xxx
Example	Set subnet mask to 255.255.255.0 #ETHERNET,2,255.255.255.0<CR>

GET SUBNET MASK	
Syntax	?ETHERNET,2<CR>
2	Get subnet mask
Example	Query the QS system for the subnet mask ?ETHERNET,2<CR> Response for the gateway: ~ETHERNET,2,255.255.255.0<CR>

CHANGE LOGIN INFORMATION	
Syntax	#ETHERNET,3,<user>,<old_login>,<new_login><CR>
3	Change the login information for the specified user
<user>	1 or 2
<old_login>	The current password for the specified user
<new_login>	The new desired password for the specified user Up to 8 characters, case sensitive
Example	Change the login for user 2 from 'james' to 'Jimmy' user = 2 old_login = james new_login = Jimmy #ETHERNET,3,2,james,Jimmy<CR>
Additional Information	It is important to change the login information from the default. The default logins are published, and if left on an open network, the QSE-CI-NWK-E could be accessed by unauthorized users.

GET LOGIN INFORMATION	
Syntax	?ETHERNET,3,<user><CR>
3	Get the current login information
<user>	1 or 2; 0 is all users
<address>	xxx.xxx.xxx.xxx
Example	Query the QS system for login information for all users ?ETHERNET,3,0<CR> The response for the login query returns the login information for all users ~ETHERNET,3,1,Jacob ~ETHERNET,3,2,Jimmy Query the QS system for login information for user 1 ?ETHERNET,3,1<CR> The response for the login query returns the login information for all users 1 and user 2 ~ETHERNET,3,1,Jacob

Reset Strings

The reset command restarts the QSE-CI-NWK-E. It is critical for making Ethernet settings take effect, or for clearing out memory entries.

RESTART THE DEVICE	
Syntax	#RESET,0<CR>
0	Resets the QSE-CI-NWK-E. This command is critical for making the Ethernet settings take effect. Saved commands are retained; unsaved commands are lost.
Example	Reset the QSE device you are connected to. #RESET,0<CR>

RESTORE TO FACTORY DEFAULTS	
Syntax	#RESET,1<CR>
1	After a second (confirming) prompt, resets the name and preferences database for the QSE-CI-NWK-E.
Example	Reset the preferences for the QSE device you are connected to; preferences revert to the factory defaults. #RESET,1<CR>

Save Strings

The save command copies the contents of the name database, style settings and monitoring settings to permanent memory, so they can be maintained after a power failure. Note that the system has an autosave feature enabled, which initiates the SAVE command automatically approximately every 2 minutes.

SAVE	
Syntax	#SAVE<CR>
Example	Saves the QSE databases so that after a restart, the settings are not lost. #SAVE<CR> Response: ~SAVE

Style Strings

Style determines the formatting for the responses from the computer to the user.

ENABLE/DISABLE HEXADECIMAL READOUT OF ZONES	
Syntax	#STYLE,1,<action><CR>
1	Style = Zone levels are read back as hexadecimal
action	1 = enabled 2 = disabled
Example	Enable hex readout of zone levels #STYLE,1,1<CR>
Applied Example	Query the zone level of device 0x00b001 ?DEVICE,0x00b001,1,14<CR> With hexadecimal readout enabled, the reply reads: ~DEVICE,0x00b001,1,14,0x3800 With hexadecimal readout disabled, the reply reads: ~DEVICE,0x00b001,1,14,22

QUERY STATUS OF HEXADECIMAL READOUT OF ZONES	
Syntax	?STYLE,1<CR>
1	Style = Zone levels are read back as hexadecimal
Example	Query the QS system to check if hex readout of zones is enabled ?STYLE,1<CR> Response (if enabled): ~STYLE,1,1<CR>

ENABLE/DISABLE CUSTOM NAMES	
Syntax	#STYLE,2,<action><CR>
2	Style = Custom names, not serial ID numbers, are returned for devices on the link
action	1 = enabled 2 = disabled
Example	Enable custom names to be returned instead of device serial ID numbers #STYLE,2,1<CR>
Applied Example	Query the zone level of device 0x00b001 (named Dev2) ?DEVICE,0x00b001,1,14<CR> With custom names enabled, the reply reads: ~DEVICE,Dev2,1,14,0x3800

QUERY STATUS OF CUSTOM NAMES	
Syntax	?STYLE,2<CR>
2	Style = Custom names, not serial ID numbers, are returned for devices on the link
Example	Query the QS system to check if custom names are enabled ?STYLE,2<CR> Response (if enabled): ~STYLE,2,1<CR>

Style Strings (continued)

ENABLE/DISABLE EXTRA PRECISION	
Syntax	#STYLE,3,<action><CR>
3	Style = Zone levels are read back with 2 places past the decimal point
action	1 = enabled 2 = disabled
Example	Enable zone levels to read back with 2 places past the decimal point #STYLE,3,1<CR>
Applied Example	Query the zone level of device 0x00b001 ?DEVICE,0x00b001,1,14<CR> With extra precision enabled, the reply reads: ~DEVICE,0x00b001,1,14,21.96 With extra precision disabled, the reply reads: ~DEVICE,0x00b001,1,14,22

QUERY STATUS OF EXTRA PRECISION	
Syntax	?STYLE,3<CR>
3	Style = Zone levels are read back with 2 places past the decimal point
Example	Query the QS system to check if extra precision of zone level readout is enabled ?STYLE,3<CR> Response (if enabled): ~STYLE,3,1<CR>

ENABLE/DISABLE EXPANDED PROMPT	
Syntax	#STYLE,4,<action><CR>
4	Style = When disabled, prompt reads: QSE> When enabled, expanded prompt reads: <user>@<ID>> If connecting through RS232, <user> = RS232
action	1 = enabled 2 = disabled
Example	Enable expanded prompt to include the user and ID #STYLE,4,1<CR>
Applied Example	Enable prompt #MONITORING,12,1<CR> Prompt if expanded prompt enabled and connected over RS232, and QS is named Dev5: RS232@Dev5> Prompt if expanded prompt disabled: QSE>

QUERY STATUS OF EXPANDED PROMPT	
Syntax	?STYLE,4<CR>
4	Style = When disabled, prompt reads: QSE> When enabled, expanded prompt reads: <user>@<ID>>
Example	Query the QS system to check if expanded prompt is enabled ?STYLE,4<CR> Response (if enabled): ~STYLE,4,1<CR>

Style Strings (continued)

QUERY STATUS OF ALL STYLES	
Syntax	?STYLE,255<CR>
255	Style = Query the status of all styles (enabled or disabled)
Example	<p>Query the QS system to check the status of all styles ?STYLE,255<CR></p> <p>Sample Response Strings:</p> <p>~STYLE,1,1 Hexadecimal readout is enabled ~STYLE,2,2 Custom names are disabled ~STYLE,3,1 Extra precision is enabled ~STYLE,4,2 Expanded prompt is disabled</p>

Name Strings

The NAME commands assign names to devices, so that they may be referred to in a more logical fashion. No two devices may have the same name. If a device name does not match the name stored in the QSE database, the QSE outputs a ~NAME response when the device announces its name. These announcements are generated when the QSE is power cycled, when a device's name changes, and when a *GRAFIK Eye QS* gathers link details.

The primary purpose of names, other than increasing readability, is to allow for device replacement without additional programming. To replace a device, please contact Lutron Technical Support.

NAME A DEVICE	
Syntax	#NAME,<ID>,<name><CR>
ID	Device ID may be entered as the serial ID number or the currently assigned name.
name	The new name of the ID to be used to reference this serial ID number or previous name. Rules for the name: It must be less than 32 characters. It may not start with '0x' It cannot be 'ALL_DEVICES' It cannot start or end with a space Names are not case-sensitive (e.g., GRAFIK1 = grafik1) Spaces within names count as characters and must be used consistently
Example	Set name of device with serial ID number 00AC123D to 'Exterior Lights' #NAME,0x00AC123D,Exterior Lights<CR> Set name of device with name 'Grafik Eye 1' to 'Kitchen Lights' #NAME,Grafik Eye 1,Kitchen Lights<CR>
Additional Information	When you name a device, the name is stored in both the QSE and the device you name. If the QSE is restarted, all saved device names are retained. If the QSE is reformatted, all device names saved in the QSE are lost, but the devices still retain their own names. For more information, see the RESET commands. When the QSE boots, it requests names from all devices on the link. The SAVE command will then store all those names in the QSE.

Name Strings (continued)

GET NAME FROM SERIAL ID NUMBER	
Syntax	?NAME,<ID><CR>
ID	Device ID may be entered as the serial ID number or the currently assigned name. Use ALL_DEVICES or 0xFFFFFFFF to query all devices on the link.
Example	<p>Get name of device with serial ID number 00AC123D ?NAME,0x00AC123D<CR></p> <p>Response, if name of specified device is 'Grafik Eye 1' ~NAME, 0x00AC123D,Grafik Eye 1</p> <p>Get serial ID number of device with name 'Grafik Eye 1' ?NAME,Grafik Eye 1<CR></p> <p>Response, if serial ID number of specified device is 00AC123D ~NAME,Grafik Eye 1,0x00AC123D</p> <p>Get names of all devices on the link ?NAME,ALL_DEVICES<CR></p> <p>~NAME,Dev1,0x000b0001 ~NAME,Dev2,0x000b0002 ~NAME,Dev3,0x000b0003 ~NAME,Dev4,0x000b0004 ~NAME,Dev5,0x00250001</p>

Details String

The Details query returns information from a GRAFIK Eye QS device. Information includes product family, product model, software version, boot code software version, and hardware version.

GET DETAILS FROM DEVICE	
Syntax	?DETAILS,<ID><CR>
ID	Device ID may be entered as the serial ID number or the currently assigned name. Use ALL_DEVICES or 0xFFFFFFFF to query all devices on the link.
Example	<p>Get details of device with serial ID number 00AC123D ?DETAILS,0x00AC123D<CR></p> <p>Response (see explanation below) ~DETAILS,SN:0x00AC123D,NAME:Grafik Eye 1,FAMILY:GRAFIK_EYE(2),PRODUCT:QSG(1),CODE:1.70,BOOT:2.1,HW:1.1</p> <p>Product family = <i>GRAFIK Eye</i> Product model = QSG Software version = 1.70 Boot code software version = 2.1 Hardware version = 1.1</p>

Error Response Strings

If the QSE-CI-NWK-E does not understand an integration string command or query, it generates an ~ERROR response. The string processing stops after one bad argument, so errors will only come from the first bad argument. The generation of error notices is controlled with monitoring flags. The Error commands evaluate syntax only; they are not returned for valid commands sent to bad serial ID numbers, incorrect components, or incorrect component/action combinations.

ERROR STRING FORMAT	
Syntax	~ERROR,<ARGUMENT #>,<ARGUMENT STRING>,<ERROR DESCRIPTION>,<ERROR DESCRIPTION>, . . . , <ERROR DESCRIPTION>
Argument #	Specifies which argument was invalid
Argument string	Gives the text of the offending argument
Error description	For each error generated by the bad argument, a brief description of why it was incorrect
Example	<p>Each of the examples shown below give the erroneous command and the ~ERROR string generated.</p> <pre>#DEVICE,0x00AX123D, 4, 2, 105, 3:45R<CR> ~ERROR,1,~DEVICE,Command not found Mistake: 'Devise' is not a command</pre> <pre>#DEVICE,0x00AX123D, 4, 2, 105, 3:45R<CR> ~ERROR,2,0x00AX123D,Bad Device ID,Bad hex-to-number conversion Mistake : 00AX123D is not a valid hexadecimal value</pre> <pre>#DEVICE,0x00A0123D,4,2,105,3:45R<CR> ~Error,5,105,Value out of range Mistake: 105 is out of range (value must be 0-100)</pre> <pre>#DEVICE,0x00A0123D,4,2,95,3:45R<CR> ~Error,6,3:45R,Bad text-to-uint conversion,Bad text-to-time conversion Mistake: 3:45R is not a valid fade time</pre> <pre>#DEVICE,0x00A0123D,4,2,95,3:45<CR> Valid command; no error response generated</pre>

**APPENDIX A: GRAFIK EYE QS COMPONENT LIST:
COMPONENT NUMBERS FOR GRAFIK EYE QS BUTTONS**

Button Components for Simulated Button Presses

Button Press Active: These buttons execute the desired action upon the button *press*

Button Release Active: These buttons execute the desired action upon the button *release*

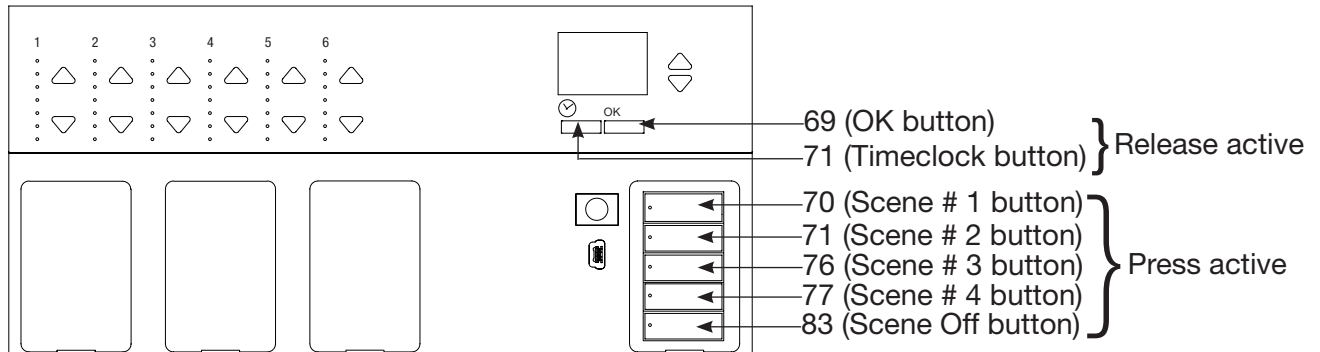

Button Components for Simulated Button Presses

Button Press and Release: These buttons execute the desired action upon the button *press and release*

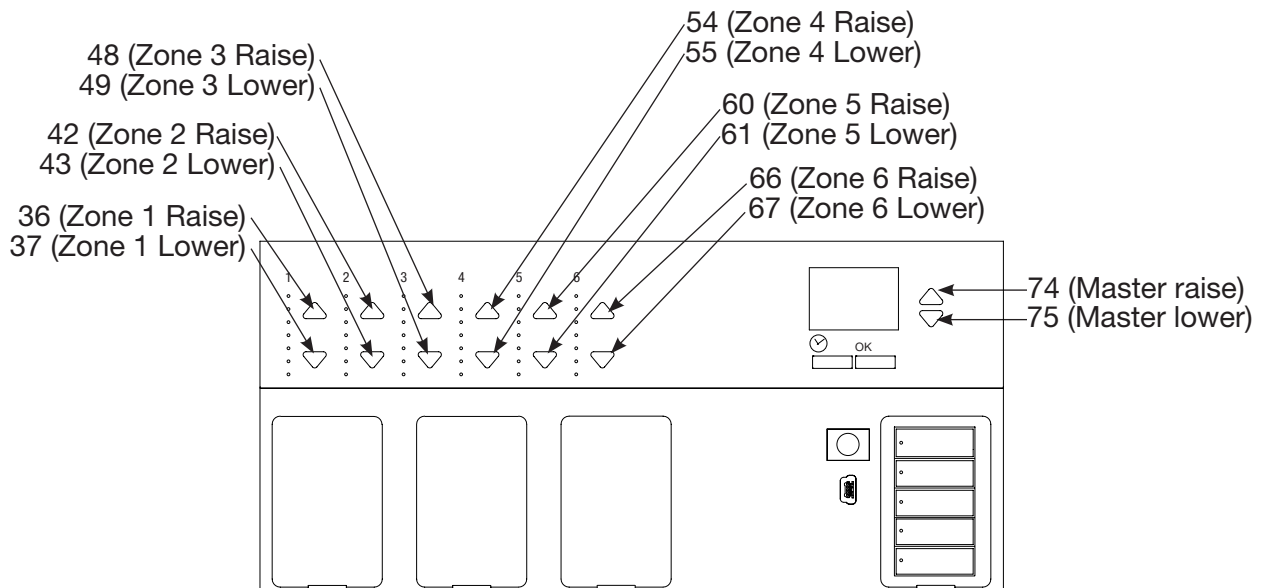

Button Components

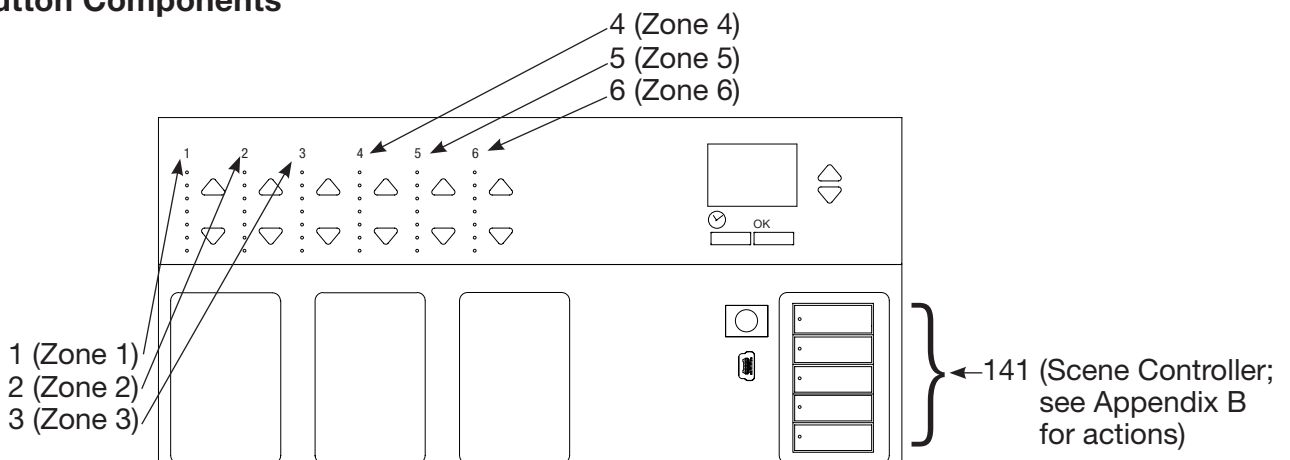

APPENDIX A: GRAFIK EYE QS COMPONENT LIST (SHADE INFORMATION)

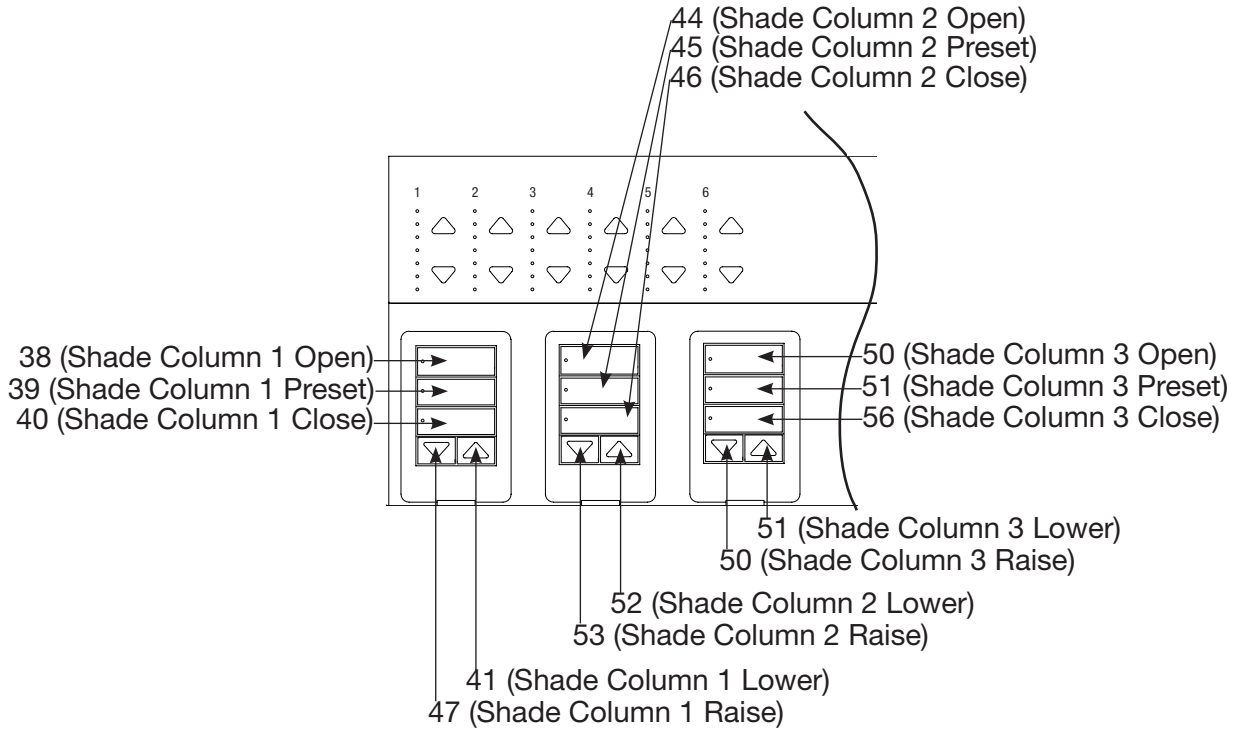

COMPONENT	ACTION	DESCRIPTION	VALID VALUES
0	7	Select Preassigned Preset	17 = Open 18 = Closed 26 = 75% open 27 = 50% open 28 = 25% open
	14	Level	Decimal Input Mode: 0 – 100 0.00 – 100.00 Hexadecimal Input Mode: 0x0000 – 0xFFFF
	21	Time to destination (response only)	Seconds

**APPENDIX A: GRAFIK EYE QS COMPONENT LIST:
COMPONENT NUMBERS FOR SEETOUCH® QS KEYPAD BUTTONS**

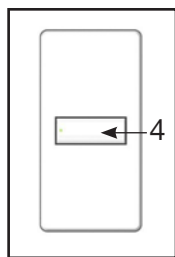

QSWS2-1B

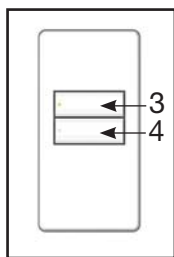

QSWS2-2B

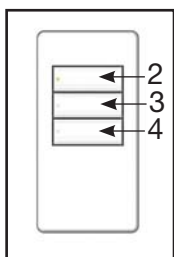

QSWS2-3B

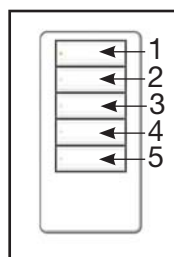

QSWS2-5B

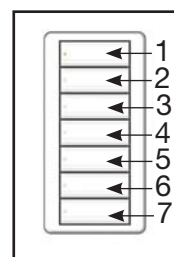

QSWS2-7B

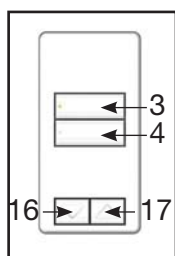

QSWS2-2BRL

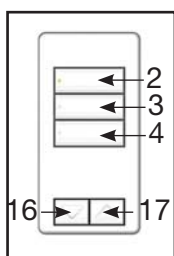

QSWS2-3BRL

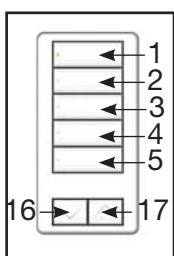

QSWS2-5BRL

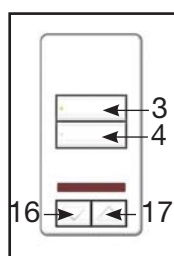

QSWS2-2BRLIR

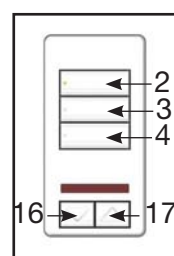

QSWS2-3BRLIR

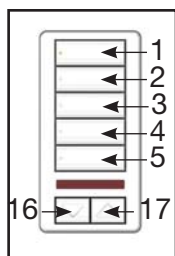

QSWS2-5BRLIR

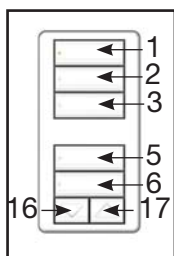

QSWS2-1RLD

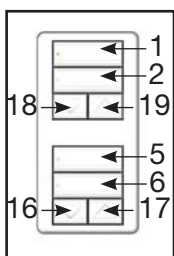

QSWS2-2RLD

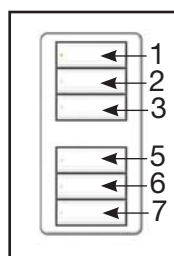

QSWS2-3BD

Note: Simulated button presses not enabled for keypads.

APPENDIX B: COMPONENT ACTIONS AND PARAMETERS

COMPONENT	ACTION	DESCRIPTION	PARAMETER(S)	VALID VALUES
0 (used in Query)	0	All actions of all components		
	7	All scene values of all components		
	14	All zone intensities of all components		
Button	3	Button press on device		
	4	Button release on device		
Scene Controller	7	Select Scene # (Command) Scene Value (Query)	Scene number	0 – 16
	15	Set Zone Lock (all zone intensity changes are temporary)	On or Off	0 is Off 1 is On
	16	Set Scene Lock (the device will not change scenes)	On or Off	0 is Off 1 is On
	17	Set Sequencing (the device cycles through scenes)	Which scene #s to sequence through	0 is no sequencing 1 sequences scene #s 1-4 2 sequences scene #s 5-16
	18	Master Raise		
	19	Master Lower		
	20	Stop Master Raise/Lower		
Zone Controller	14	Set zone level (Command) Zone Intensity (Query)	Level	Decimal Input Mode: 0 – 100 0.00 – 100.00 Hexadecimal Input Mode: 0x0000 – 0xFFFF Note: NOT all levels can be achieved on all devices
			Fade	Seconds Minutes:Seconds Hours:Minutes:Seconds

Internet: www.lutron.com
E-mail: product@lutron.com

WORLD HEADQUARTERS

USA

Lutron Electronics Co., Inc.
7200 Suter Road, Coopersburg, PA 18036-1299
TEL +1.610.282.3800
FAX +1.610.282.1243
Toll-Free 1.888.LUTRON1
Technical Support 1.800.523.9466

North and South America Technical Hotlines

USA, Canada, Caribbean: 1.800.523.9466
Mexico: +1.888.235.2910
Central/South America: +1.610.282.6701

EUROPEAN HEADQUARTERS

United Kingdom
Lutron EA Ltd.
6 Sovereign Close, London, E1W 3JF United Kingdom
TEL +44.(0)20.7702.0657
FAX +44.(0)20.7480.6899
FREEPHONE (UK) 0800.282.107
Technical support +44.(0)20.7680.4481

ASIAN HEADQUARTERS

Singapore
Lutron GL Ltd.
15 Hoe Chiang Road, #07-03 Euro Asia Centre, Singapore
089316
TEL +65.6220.4666
FAX +65.6220.4333

Asia Technical Hotlines

Northern China: 10.800.712.1536
Southern China: 10.800.120.1536
Hong Kong: 800.901.849
Indonesia: 001.803.011.3994
Japan: +81.3.5575.8411
Macau: 0800.401
Singapore: 800.120.4491
Taiwan: 00.801.137.737
Thailand: 001.800.120.665853
Other countries: +65.6220.4666

Windows is a registered trademark of Microsoft, Inc.
GRAFIK Eye, Sivoia, Lutron, and the Sunburst logo are
registered trademarks and GRAFIK Eye QS is a trademark of
Lutron Electronics Co., Inc.
©2008 Lutron Electronics, Inc.

Replacement Kit Instructions

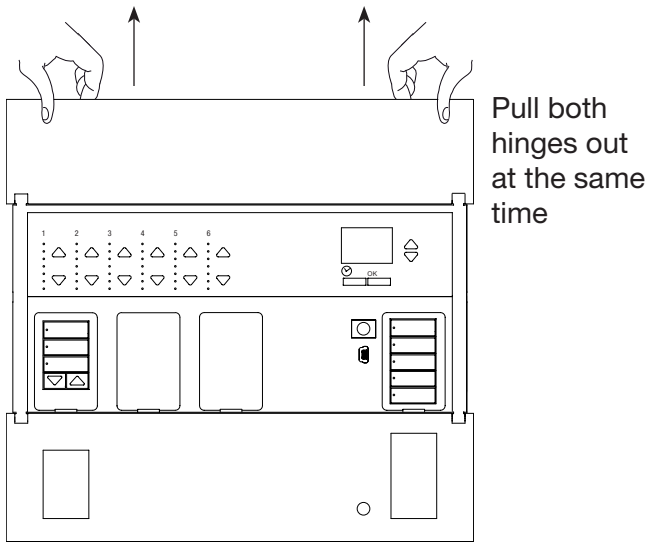

Faceplate Replacement

To remove either faceplate, open it fully (flush to the wall), and pull up (for the top faceplate) or down (for the bottom faceplate) to pull both hinges out of their slots at the same time.

Replace by sliding the hinges back into their slots.

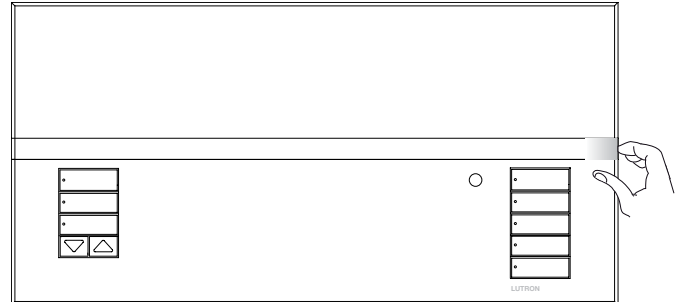

Stripe Replacement

To remove the stripe, lift the end and pull away from the faceplate until the tabs pop out of their slots.

Replace plastic stripe by pressing the tabs back into their slots. For metal stripe, remove adhesive liner and press into place.

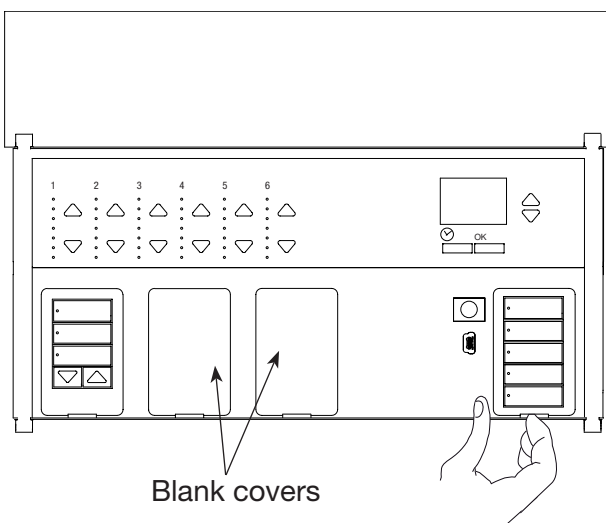

Button Kit Replacement

Note: Lighting and shade buttons are replaced the same way.

To replace a column of buttons, insert the tip of your finger into the slot at the bottom of the button column, and gently lift up. The button kit should pop out.

If you are adding a shade button kit where there is currently a blank cover, remove the lower faceplate (see above) and remove the blank cover.

Replace the button kit by gently pressing it into the opening until it snaps into place, and replace the bottom faceplate if necessary.

Warranty and Contact Information

Lutron Electronics Co., Inc. One Year Limited Warranty

For a period of one year from the date of purchase, and subject to the exclusions and restrictions described below, Lutron warrants each new unit to be free from manufacturing defects. Lutron will, at its option, either repair the defective unit or issue a credit equal to the purchase price of the defective unit to the Customer against the purchase price of comparable replacement part purchased from Lutron. Replacements for the unit provided by Lutron or, at its sole discretion, an approved vendor may be new, used, repaired, reconditioned, and/or made by a different manufacturer.

If the unit is commissioned by Lutron or a Lutron approved third party as part of a Lutron commissioned lighting control system, the term of this warranty will be extended, and any credits against the cost of replacement parts will be prorated, in accordance with the warranty issued with the commissioned system, except that the term of the unit's warranty term will be measured from the date of its commissioning.

EXCLUSIONS AND RESTRICTIONS

This Warranty does not cover, and Lutron and its suppliers are not responsible for:

1. Damage, malfunction or inoperability diagnosed by Lutron or a Lutron approved third party as caused by normal wear and tear, abuse, misuse, incorrect installation, neglect, accident, interference or environmental factors, such as (a) use of incorrect line voltages, fuses or circuit breakers; (b) failure to install, maintain and operate the unit pursuant to the operating instructions provided by Lutron and the applicable provisions of the National Electrical Code and of the Safety Standards of Underwriter's Laboratories; (c) use of incompatible devices or accessories; (d) improper or insufficient ventilation; (e) unauthorized repairs or adjustments; (f) vandalism; or (g) an act of God, such as fire, lightning, flooding, tornado, earthquake, hurricane or other problems beyond Lutron's control.
2. On-site labor costs to diagnose issues with, and to remove, repair, replace, adjust, reinstall and/or reprogram the unit or any of its components.
3. Equipment and parts external to the unit, including those sold or supplied by Lutron (which may be covered by a separate warranty).
4. The cost of repairing or replacing other property that is damaged when the unit does not work properly, even if the damage was caused by the unit.

EXCEPT AS EXPRESSLY PROVIDED IN THIS WARRANTY, THERE ARE NO EXPRESS OR IMPLIED WARRANTIES OF ANY TYPE, INCLUDING ANY IMPLIED WARRANTIES OF FITNESS FOR A PARTICULAR PURPOSE OR MERCHANTABILITY. LUTRON DOES NOT WARRANT THAT THE UNIT WILL OPERATE WITHOUT INTERRUPTION OR BE ERROR FREE.

NO LUTRON AGENT, EMPLOYEE OR REPRESENTATIVE HAS ANY AUTHORITY TO BIND LUTRON TO ANY AFFIRMATION, REPRESENTATION OR WARRANTY CONCERNING THE UNIT. UNLESS AN AFFIRMATION, REPRESENTATION OR WARRANTY MADE BY AN AGENT, EMPLOYEE OR REPRESENTATIVE IS SPECIFICALLY INCLUDED HEREIN, OR IN STANDARD PRINTED MATERIALS PROVIDED BY LUTRON, IT DOES NOT FORM A PART OF THE BASIS OF ANY BARGAIN BETWEEN LUTRON AND CUSTOMER AND WILL NOT IN ANY WAY BE ENFORCEABLE BY CUSTOMER.

IN NO EVENT WILL LUTRON OR ANY OTHER PARTY BE LIABLE FOR EXEMPLARY, CONSEQUENTIAL, INCIDENTAL OR SPECIAL DAMAGES (INCLUDING, BUT NOT LIMITED TO, DAMAGES FOR LOSS OF PROFITS, CONFIDENTIAL OR OTHER INFORMATION, OR PRIVACY; BUSINESS INTERRUPTION; PERSONAL INJURY; FAILURE TO MEET ANY DUTY, INCLUDING OF GOOD FAITH OR OF REASONABLE CARE; NEGLIGENCE, OR ANY OTHER PECUNIARY OR OTHER LOSS WHATSOEVER), NOR FOR ANY REPAIR WORK UNDERTAKEN WITHOUT LUTRON'S WRITTEN CONSENT ARISING OUT OF OR IN ANY WAY RELATED TO THE INSTALLATION, DEINSTALLATION, USE OF OR INABILITY TO USE THE UNIT OR OTHERWISE UNDER OR IN CONNECTION WITH ANY PROVISION OF THIS WARRANTY, OR ANY AGREEMENT INCORPORATING THIS WARRANTY, EVEN IN THE EVENT OF THE FAULT, TORT (INCLUDING NEGLIGENCE), STRICT LIABILITY, BREACH OF CONTRACT OR BREACH OF WARRANTY OF LUTRON OR ANY SUPPLIER, AND EVEN IF LUTRON OR ANY OTHER PARTY WAS ADVISED OF THE POSSIBILITY OF SUCH DAMAGES.

NOTWITHSTANDING ANY DAMAGES THAT CUSTOMER MIGHT INCUR FOR ANY REASON WHATSOEVER (INCLUDING, WITHOUT LIMITATION, ALL DIRECT DAMAGES AND ALL DAMAGES LISTED ABOVE), THE ENTIRE LIABILITY OF LUTRON AND OF ALL OTHER PARTIES UNDER THIS WARRANTY ON ANY CLAIM FOR DAMAGES ARISING OUT OF OR IN CONNECTION WITH

THE MANUFACTURE, SALE, INSTALLATION, DELIVERY, USE, REPAIR, OR REPLACEMENT OF THE UNIT, OR ANY AGREEMENT INCORPORATING THIS WARRANTY, AND CUSTOMER'S SOLE REMEDY FOR THE FOREGOING, WILL BE LIMITED TO THE AMOUNT PAID TO LUTRON BY CUSTOMER FOR THE UNIT. THE FOREGOING LIMITATIONS, EXCLUSIONS AND DISCLAIMERS WILL APPLY TO THE MAXIMUM EXTENT ALLOWED BY APPLICABLE LAW, EVEN IF ANY REMEDY FAILS ITS ESSENTIAL PURPOSE.

TO MAKE A WARRANTY CLAIM

To make a warranty claim, promptly notify Lutron within the warranty period described above by calling the Lutron Technical Support Center at (800) 523-9466. Lutron, in its sole discretion, will determine what action, if any, is required under this warranty. To better enable Lutron to address a warranty claim, have the unit's serial and model numbers available when making the call. If Lutron, in its sole discretion, determines that an on-site visit or other remedial action is necessary, Lutron may send a Lutron Services Co. representative or coordinate the dispatch of a representative from a Lutron approved vendor to Customer's site, and/or coordinate a warranty service call between Customer and a Lutron approved vendor.

This warranty gives you specific legal rights, and you may also have other rights which vary from state to state. Some states do not allow limitations on how long an implied warranty lasts, so the above limitation may not apply to you. Some states do not allow the exclusion or limitation of incidental or consequential damages, so the above limitation or exclusion may not apply to you.

These products may be covered under one or more of the following U.S. patents: D461,782; and corresponding foreign patents. Other U.S. and foreign patents may be pending.

Lutron, the sunburst logo, GRAFIK Eye are registered trademarks of Lutron Electronics Co., Inc.

© 2007 Lutron Electronics Co., Inc.

Internet: www.lutron.com
E-mail: product@lutron.com

World Headquarters

USA
Lutron Electronics Co., Inc.
7200 Suter Road, Coopersburg, PA 18036-1299
TEL +1.610.282.3800
FAX +1.610.282.1243
Toll-Free 1.888.LUTRON1
Technical Support 1.800.523.9466

Brazil

Lutron BZ do Brasil Ltda.
AV, Brasil, 239, Jardim America
Sao Paulo-SP, CEP: 01431-000, Brazil
TEL +55.11.3885.5152
FAX +55.11.3887.7138

North and South America Technical Hotlines
USA, Canada, Caribbean: 1.800.523.9466
Mexico: +1.888.235.2910
Central/South America: +1.610.282.6701

European Headquarters

United Kingdom
Lutron EA Ltd.
6 Sovereign Close, London, E1W 3JF
United Kingdom
TEL +44.(0)20.7702.0657
FAX +44.(0)20.7480.6899
FREEPHONE (UK) 0800.282.107
Technical support +44.(0)20.7680.4481

France
Lutron LTC, S.A.R.L.
90 rue de Villiers, 92300 Levallois-Perret
France
TEL +33.(0)1.41.05.42.80
FAX +33.(0)1.41.05.01.80
FREEPHONE 0800.90.12.18

Germany
Lutron Electronics GmbH, Landsberger Allee
201, 13055 Berlin, Germany
TEL +49.(0)30.9710.4590
FAX +49.(0)30.9710.4591
FREEPHONE 00800.5887.6635

Italy
Lutron LDV, S.r.l.
FREEPHONE 800.979.208

Spain, Barcelona
Lutron CC, S.R.L.
Gran Via del Carlos III, 84, planta 3a,
08028, Barcelona, Spain
TEL +34.93.496.57.42
FAX +34.93.496.57.01
FREEPHONE 0900.948.944

Spain, Madrid
Lutron CC, S.R.L.
Calle Orense, 85, 28020 Madrid, Spain
TEL +34.91.567.84.79
FAX +34.91.567.84.78
FREEPHONE 0900.948.944

Asian Headquarters

Singapore
Lutron GL Ltd.
15 Hoe Chiang Road, #07-03 Euro Asia
Centre, Singapore 089316
TEL +65.6220.4666
FAX +65.6220.4333

China, Beijing
Lutron GL Ltd. Beijing Representative Office
5th Floor, China Life Tower
No. 16 Chaowai Street, Chaoyang District,
Beijing 100020 China
TEL +86.10.5877.1817
FAX +86.10.5877.1816

China, Guangzhou
Lutron GL Ltd. Guangzhou Representative
Office
Suite A09, 23/F Tower A, Centre Plaza
161 Lin He Xi Lu, Tian He District, Guang-
zhou 510620 China
TEL +86.20.2885.8266
FAX +86.20.2885.8366

China, Shanghai
Lutron GL Ltd., Shanghai Representative
Office
Suite 07, 39th Floor, Plaza 66
1266 Nan Jing West Road, Shanghai,
200040 China
TEL +86.21.6288.1473
FAX +86.21.6288.1751

China, Hong Kong
Lutron GL Ltd.
Unit 2808, 28/F, 248 Queen's Road East
Wanchai, Hong Kong
TEL +852.2104.7733
FAX +852.2104.7633

Japan
Lutron Asuka Co. Ltd.
No. 16 Kowa Building, 4F, 1-9-20
Akasaka, Minato-ku, Tokyo 107-0052 Japan
TEL +81.3.5575.8411
FAX +81.3.5575.8420
FREEPHONE 0120.083.417

Asia Technical Hotlines
Northern China: 10.800.712.1536
Southern China: 10.800.120.1536
Hong Kong: 800.901.849
Indonesia: 001.803.011.3994
Japan: +81.3.5575.8411
Macau: 0800.401
Singapore: 800.120.4491
Taiwan: 00.801.137.737
Thailand: 001.800.120.665853
Other countries: +800.120.4491



Lutron Electronics Co., Inc.
Made and printed in U.S.A. 03/07
P/N 032-180 Rev. A

Replacement Instructions

Important Notes:

Please Read Before Installation

1. Ensure all controls are correctly wired and mounted before installing faceplates.
2. Ensure yokes of controls are free from debris (e.g. plaster, spackling compound) before installing faceplate adapter and faceplate.

Cleaning Instructions

To clean, wipe with a clean damp cloth. DO NOT use any chemical cleaning solutions.

Installation

1. Remove the currently installed faceplate, adapter, and buttons.
 - a. Snap off the faceplate.
 - b. Remove 2 screws from the faceplate adapter and remove adapter (if present).
 - c. Remove button assembly from keypad by gently prying it from the top.

Removing the faceplate adapter is required for insert models or if the new faceplate kit is a different color than the one being removed.
2. Snap on the buttons by lining up the two tabs on the bottom of the buttons with the two slots in the keypad just above the lower keypad mounting screw. Using your thumbs, press in the bottom, and then snap in the top of the buttons.
3. Attach faceplate adapter to controls with screws provided.
4. Attach the faceplate to the faceplate adapter by pressing at the top and bottom of the faceplate until it snaps into place.

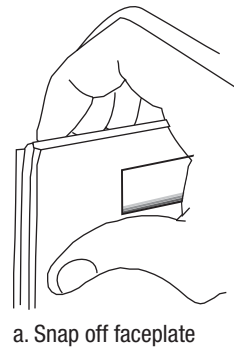
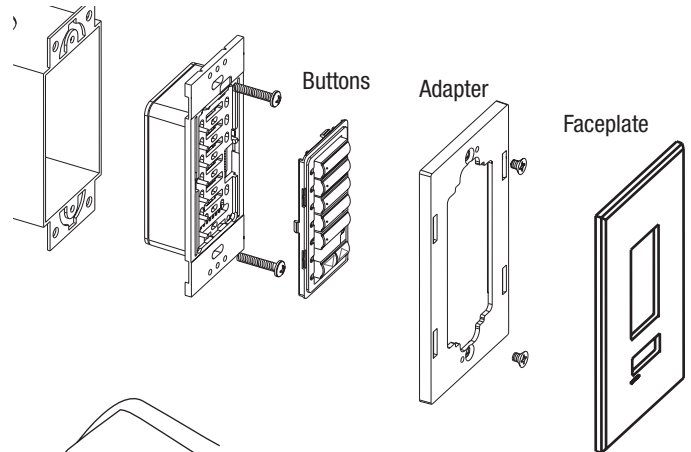

a. Snap off faceplate

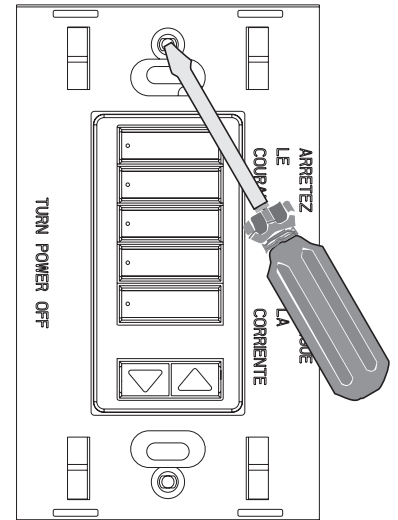

b. Remove screws and faceplate adapter (if present)

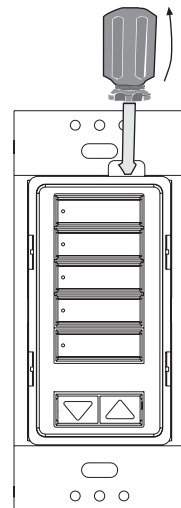

c. Gently pry out buttons

Warranty and Contact Information

Lutron Electronics Co., Inc. One Year Limited Warranty

For a period of one year from the date of purchase, and subject to the exclusions and restrictions described below, Lutron warrants each new unit to be free from manufacturing defects. Lutron will, at its option, either repair the defective unit or issue a credit equal to the purchase price of the defective unit to the Customer against the purchase price of comparable replacement part purchased from Lutron. Replacements for the unit provided by Lutron or, at its sole discretion, an approved vendor may be new, used, repaired, reconditioned, and/or made by a different manufacturer.

If the unit is commissioned by Lutron or a Lutron approved third party as part of a Lutron commissioned lighting control system, the term of this warranty will be extended, and any credits against the cost of replacement parts will be prorated, in accordance with the warranty issued with the commissioned system, except that the term of the unit's warranty term will be measured from the date of its commissioning.

EXCLUSIONS AND RESTRICTIONS

This Warranty does not cover, and Lutron and its suppliers are not responsible for:

1. Damage, malfunction or inoperability diagnosed by Lutron or a Lutron approved third party as caused by normal wear and tear, abuse, misuse, incorrect installation, neglect, accident, interference or environmental factors, such as (a) use of incorrect line voltages, fuses or circuit breakers; (b) failure to install, maintain and operate the unit pursuant to the operating instructions provided by Lutron and the applicable provisions of the National Electrical Code and of the Safety Standards of Underwriter's Laboratories; (c) use of incompatible devices or accessories; (d) improper or insufficient ventilation; (e) unauthorized repairs or adjustments; (f) vandalism; or (g) an act of God, such as fire, lightning, flooding, tornado, earthquake, hurricane or other problems beyond Lutron's control.
2. On-site labor costs to diagnose issues with, and to remove, repair, replace, adjust, reinstall and/or reprogram the unit or any of its components.
3. Equipment and parts external to the unit, including those sold or supplied by Lutron (which may be covered by a separate warranty).
4. The cost of repairing or replacing other property that is damaged when the unit does not work properly, even if the damage was caused by the unit.

EXCEPT AS EXPRESSLY PROVIDED IN THIS WARRANTY, THERE ARE NO EXPRESS OR IMPLIED WARRANTIES OF ANY TYPE, INCLUDING ANY IMPLIED WARRANTIES OF FITNESS FOR A PARTICULAR PURPOSE OR MERCHANTABILITY. LUTRON DOES NOT WARRANT THAT THE UNIT WILL OPERATE WITHOUT INTERRUPTION OR BE ERROR FREE.

NO LUTRON AGENT, EMPLOYEE OR REPRESENTATIVE HAS ANY AUTHORITY TO BIND LUTRON TO ANY AFFIRMATION, REPRESENTATION OR WARRANTY CONCERNING THE UNIT. UNLESS AN AFFIRMATION, REPRESENTATION OR WARRANTY MADE BY AN AGENT, EMPLOYEE OR REPRESENTATIVE IS SPECIFICALLY INCLUDED HEREIN, OR IN STANDARD PRINTED MATERIALS PROVIDED BY LUTRON, IT DOES NOT FORM A PART OF THE BASIS OF ANY BARGAIN BETWEEN LUTRON AND CUSTOMER AND WILL NOT IN ANY WAY BE ENFORCEABLE BY CUSTOMER.

IN NO EVENT WILL LUTRON OR ANY OTHER PARTY BE LIABLE FOR EXEMPLARY, CONSEQUENTIAL, INCIDENTAL OR SPECIAL DAMAGES (INCLUDING, BUT NOT LIMITED TO, DAMAGES FOR LOSS OF PROFITS, CONFIDENTIAL OR OTHER INFORMATION, OR PRIVACY; BUSINESS INTERRUPTION; PERSONAL INJURY; FAILURE TO MEET ANY DUTY, INCLUDING OF GOOD FAITH OR OF REASONABLE CARE; NEGLIGENCE, OR ANY OTHER PECUNIARY OR OTHER LOSS WHATSOEVER), NOR FOR ANY REPAIR WORK UNDERTAKEN WITHOUT LUTRON'S WRITTEN CONSENT ARISING OUT OF OR IN ANY WAY RELATED TO THE INSTALLATION, DEINSTALLATION, USE OF OR INABILITY TO USE THE UNIT OR OTHERWISE UNDER OR IN CONNECTION WITH ANY PROVISION OF THIS WARRANTY, OR ANY AGREEMENT INCORPORATING THIS WARRANTY, EVEN IN THE EVENT OF THE FAULT, TORT (INCLUDING NEGLIGENCE), STRICT LIABILITY, BREACH OF CONTRACT OR BREACH OF WARRANTY OF LUTRON OR ANY SUPPLIER, AND EVEN IF LUTRON OR ANY OTHER PARTY WAS ADVISED OF THE POSSIBILITY OF SUCH DAMAGES.

NOTWITHSTANDING ANY DAMAGES THAT CUSTOMER MIGHT INCUR FOR ANY REASON WHATSOEVER (INCLUDING, WITHOUT LIMITATION, ALL DIRECT DAMAGES AND ALL DAMAGES LISTED ABOVE), THE ENTIRE LIABILITY OF LUTRON AND OF ALL OTHER PARTIES UNDER THIS WARRANTY ON ANY CLAIM FOR DAMAGES ARISING OUT OF OR IN CONNECTION WITH

THE MANUFACTURE, SALE, INSTALLATION, DELIVERY, USE, REPAIR, OR REPLACEMENT OF THE UNIT, OR ANY AGREEMENT INCORPORATING THIS WARRANTY, AND CUSTOMER'S SOLE REMEDY FOR THE FOREGOING, WILL BE LIMITED TO THE AMOUNT PAID TO LUTRON BY CUSTOMER FOR THE UNIT. THE FOREGOING LIMITATIONS, EXCLUSIONS AND DISCLAIMERS WILL APPLY TO THE MAXIMUM EXTENT ALLOWED BY APPLICABLE LAW, EVEN IF ANY REMEDY FAILS ITS ESSENTIAL PURPOSE.

TO MAKE A WARRANTY CLAIM

To make a warranty claim, promptly notify Lutron within the warranty period described above by calling the Lutron Technical Support Center at (800) 523-9466. Lutron, in its sole discretion, will determine what action, if any, is required under this warranty. To better enable Lutron to address a warranty claim, have the unit's serial and model numbers available when making the call. If Lutron, in its sole discretion, determines that an on-site visit or other remedial action is necessary, Lutron may send a Lutron Services Co. representative or coordinate the dispatch of a representative from a Lutron approved vendor to Customer's site, and/or coordinate a warranty service call between Customer and a Lutron approved vendor.

This warranty gives you specific legal rights, and you may also have other rights which vary from state to state. Some states do not allow limitations on how long an implied warranty lasts, so the above limitation may not apply to you. Some states do not allow the exclusion or limitation of incidental or consequential damages, so the above limitation or exclusion may not apply to you.

These products may be covered under one or more of the following U.S. patents: D461,782; and corresponding foreign patents. Other U.S. and foreign patents may be pending.

Lutron and the sunburst logo are registered trademarks and SeeTouch is a trademark of Lutron Electronics Co., Inc. © 2007 Lutron Electronics Co., Inc.

Internet: www.lutron.com
E-mail: product@lutron.com

World Headquarters

USA
Lutron Electronics Co., Inc.
7200 Suter Road, Coopersburg, PA 18036-1299
TEL +1.610.282.3800
FAX +1.610.282.1243
Toll-Free 1.888.LUTRON1
Technical Support 1.800.523.9466

Brazil

Lutron BZ do Brasil Ltda.
AV, Brasil, 239, Jardim America
Sao Paulo-SP, CEP: 01431-000, Brazil
TEL +55.11.3885.5152
FAX +55.11.3887.7138

North and South America Technical Hotlines
USA, Canada, Caribbean: 1.800.523.9466
Mexico: +1.888.235.2910
Central/South America: +1.610.282.6701

European Headquarters

United Kingdom
Lutron EA Ltd.
6 Sovereign Close, London, E1W 3JF
United Kingdom
TEL +44.(0)20.7702.0657
FAX +44.(0)20.7480.6899
FREEPHONE (UK) 0800.282.107
Technical support +44.(0)20.7680.4481

France
Lutron LTC, S.A.R.L.
90 rue de Villiers, 92300 Levallois-Perret
France
TEL +33.(0)1.41.05.42.80
FAX +33.(0)1.41.05.01.80
FREEPHONE 0800.90.12.18

Germany
Lutron Electronics GmbH, Landsberger Allee
201, 13055 Berlin, Germany
TEL +49.(0)30.9710.4590
FAX +49.(0)30.9710.4591
FREEPHONE 00800.5887.6635

Italy
Lutron LDV, S.r.l.
FREEPHONE 800.979.208

Spain, Barcelona
Lutron CC, S.R.L.
Gran Via del Carlos III, 84, planta 3a,
08028, Barcelona, Spain
TEL +34.93.496.57.42
FAX +34.93.496.57.01
FREEPHONE 0900.948.944

Spain, Madrid
Lutron CC, S.R.L.
Calle Orense, 85, 28020 Madrid, Spain
TEL +34.91.567.84.79
FAX +34.91.567.84.78
FREEPHONE 0900.948.944

Asian Headquarters

Singapore
Lutron GL Ltd.
15 Hoe Chiang Road, #07-03 Euro Asia
Centre, Singapore 089316
TEL +65.6220.4666
FAX +65.6220.4333

China, Beijing
Lutron GL Ltd. Beijing Representative Office
5th Floor, China Life Tower
No. 16 Chaowai Street, Chaoyang District,
Beijing 100020 China
TEL +86.10.5877.1817
FAX +86.10.5877.1816

China, Guangzhou
Lutron GL Ltd. Guangzhou Representative
Office
Suite A09, 23/F Tower A, Centre Plaza
161 Lin He Xi Lu, Tian He District, Guang-
zhou 510620 China
TEL +86.20.2885.8266
FAX +86.20.2885.8366

China, Shanghai
Lutron GL Ltd., Shanghai Representative
Office
Suite 07, 39th Floor, Plaza 66
1266 Nan Jing West Road, Shanghai,
200040 China
TEL +86.21.6288.1473
FAX +86.21.6288.1751

China, Hong Kong
Lutron GL Ltd.
Unit 2808, 28/F, 248 Queen's Road East
Wanchai, Hong Kong
TEL +852.2104.7733
FAX +852.2104.7633

Japan
Lutron Asuka Co. Ltd.
No. 16 Kowa Building, 4F, 1-9-20
Akasaka, Minato-ku, Tokyo 107-0052 Japan
TEL +81.3.5575.8411
FAX +81.3.5575.8420
FREEPHONE 0120.083.417

Asia Technical Hotlines
Northern China: 10.800.712.1536
Southern China: 10.800.120.1536
Hong Kong: 800.901.849
Indonesia: 001.803.011.3994
Japan: +81.3.5575.8411
Macau: 0800.401
Singapore: 800.120.4491
Taiwan: 00.801.137.737
Thailand: 001.800.120.665853
Other countries: +800.120.4491



Lutron Electronics Co., Inc.
Made and printed in U.S.A. 03/07
P/N 032-181 Rev. A

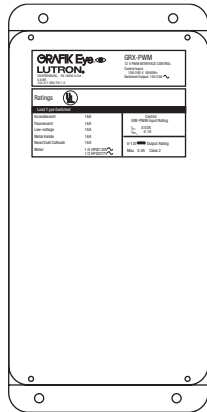

Description

The GRX-PWM provides 12 VDC Pulse Width Modulated (PWM) control and ballast switching capabilities in one enclosure. With the GRX-PWM, a GRAFIK Eye 3000 Series Control Unit* can control PWM ballasts powered by 100-277 VAC and provide switching relays that can handle the in-rush current for a full circuit of ballasts. The GRX-PWM can also be used to switch any of the load types listed below.

*GRX-PWM will also work with Lutron GP or LP panel outputs.

Product Specifications

FEATURES.....Provides a PELV (Class 2: USA) isolated 12 VDC 1 kHz PWM output signal that conforms to IEC60929 and JIS C8120-2.
Accepts a constant-gate drive fluorescent signal

INPUT VOLTAGE RATING	100/120 V ~, 50/60 Hz
SWITCHED VOLTAGE RATING	100-277 V ~, 50/60 Hz
H2 TERMINAL INPUT RATING	200 mA max
DH2 TERMINAL INPUT RATING	100 mA
12 VDC PWM OUTPUT RATING	400 mA - sources current only

Source/Load Type	Switched Hot Current 100-277 V ~
Fluorescent: Lutron Eco-10™ (TVE Series)	16 A
Electronic Capacitive Non-Dim Other Manufacturer's 12 VDC PWM Ballasts (12 VDC PWM source only)	16 A
Incandescent	16 A
Low-Voltage	16 A
Metal Halide	16 A
Neon/Cold Cathode	16 A
Motors	1/4 HP @ 100-120 V ~ 1/2 HP @ 200-277 V ~

TERMINALS Two #12-20 AWG (0.5-2.5 mm²) conductors per terminal.
MOUNTING NEMA Type 1 enclosure, indoor use only.
ENVIRONMENTAL 32-104°F (0-40°C).
WEIGHT 4.25 lb. (2 kg)

Mounting

Find a suitable location for mounting.

- Decide on the proper location for the GRX-PWM (NEMA Type 1 enclosure, indoor use only). See System Wiring Layout below.
- The environment where the GRX-PWM is placed must have an ambient temperature range of 32-104°F (0-40°C).
- Mount the enclosure vertically on a wall (screws not provided). See Mounting Diagram below.
- Mounting method must be able to support weight and forces applied during installation.
- Internal relays will click while in operation; mount where audible noise is acceptable.

System Wiring Layout

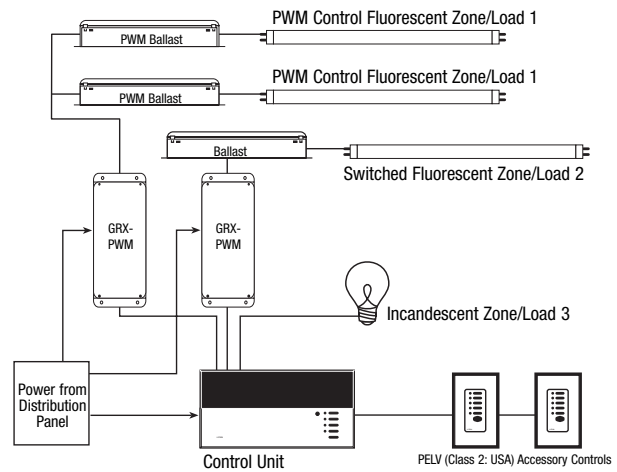

Note: When using a Control Unit, a GRX-PWM is required for each 12 VDC PWM fluorescent zone. (A 3-zone Control Unit with two fluorescent zones and one incandescent zone is shown as an example.)

Mounting Diagram

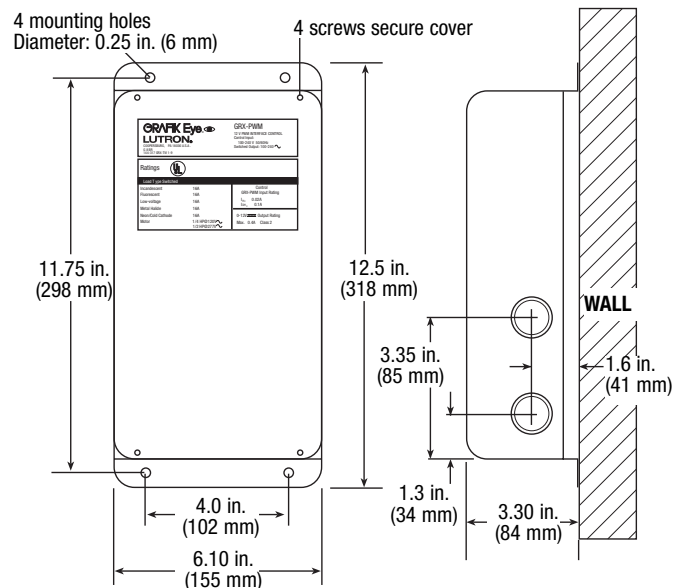

100-277 V \sim Control Interface

Important Installation Information

- Install in accordance with all national and local electrical codes.
- Check for short-circuited loads during new installations before wiring the GRX-PWM.



Caution: Multiple feeds may enter this enclosure. Locate and lock each feed circuit breaker/MCB in the OFF position before wiring the Interface.

- Proper short-circuit and overload protection must be provided at the distribution panel. You can use up to a 20 A maximum circuit breaker/MCB or equivalent (tripping curve C according to IEC 898/EN60898 is recommended) with adequate short-circuit breaking capacity for your installation.
- Terminal blocks are rated for two #12-20 AWG (0.5-2.5 mm²) wires per terminal.
- Strip 3/8 in. (10 mm) of insulation from wires.
- Wiring Diagram A shows a GRX-PWM wired from one distribution panel. If the power requirement of the complete system is less than an MCB/circuit breaker rating, one feed can be jumpered inside the enclosure (as shown).
- Wiring Diagram B shows a GRX-PWM wired from two separate distribution panels that may be different phases or voltages.

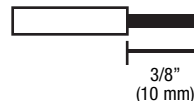

- Use the internal terminal block label to see where to land wires.
 - The label shows two separate Hot terminals (H1 & H2).
 - H1 is the Hot feed to power the lighting load.
 - H2 is the Hot feed that powers internal circuitry of the GRX-PWM.
 - H2 has a 100/120 V \sim connection. Do **not** use the unlabeled terminal.

Note 1: Not all terminal blocks receive a connection.

Note 2: The power feed to the Control Unit and H2 of the GRX-PWM must be the same phase! PELV (Class 2: USA), 12 V \equiv PWM wiring from a ballast to the GRX-PWM must be separated from the power wiring. Enter the PELV (Class 2: USA) wires through the knockout adjacent to the 12 V \equiv PWM terminal blocks. The Nomex[®] barrier ensures separation and is flexible to allow access to the terminals. The barrier must be in place when installation is complete.

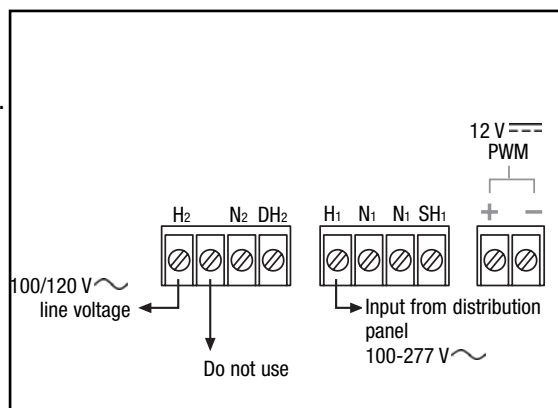

GRX-PWM Internal Terminal Block Label Definitions

H2 100/120 V \sim	Power input for GRX-PWM control (line voltage must be 100/120 V \sim only)
N2	Neutral for GRX-PWM control
DH2	GRAFIK Eye 3000 Series Control Unit Lighting Zone connection (Phase Control Input to GRX-PWM)
H1	Power input for lighting load (switched voltage can be 100-277 V \sim)
N1	Neutral for lighting load (2 terminals provided and internally tied together — one for input neutral, and one for load neutral)
SH1	Switched output to power lighting load
+ -	PWM control signal terminals

Wiring Diagram A: 100/120 V ~ GRX-PWM: 1 Distribution Panel

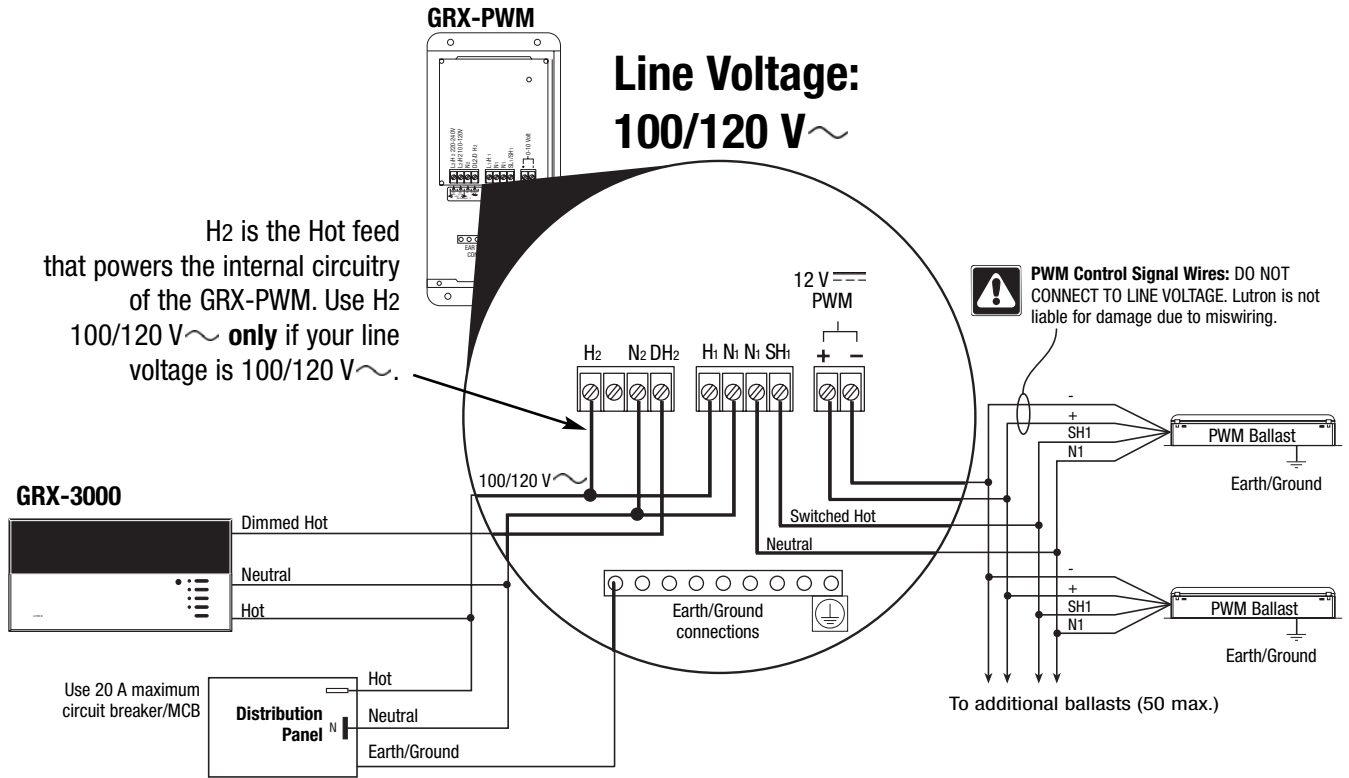

Wiring Diagram B: 100-277 V ~ GRX-PWM: 2 Distribution Panels

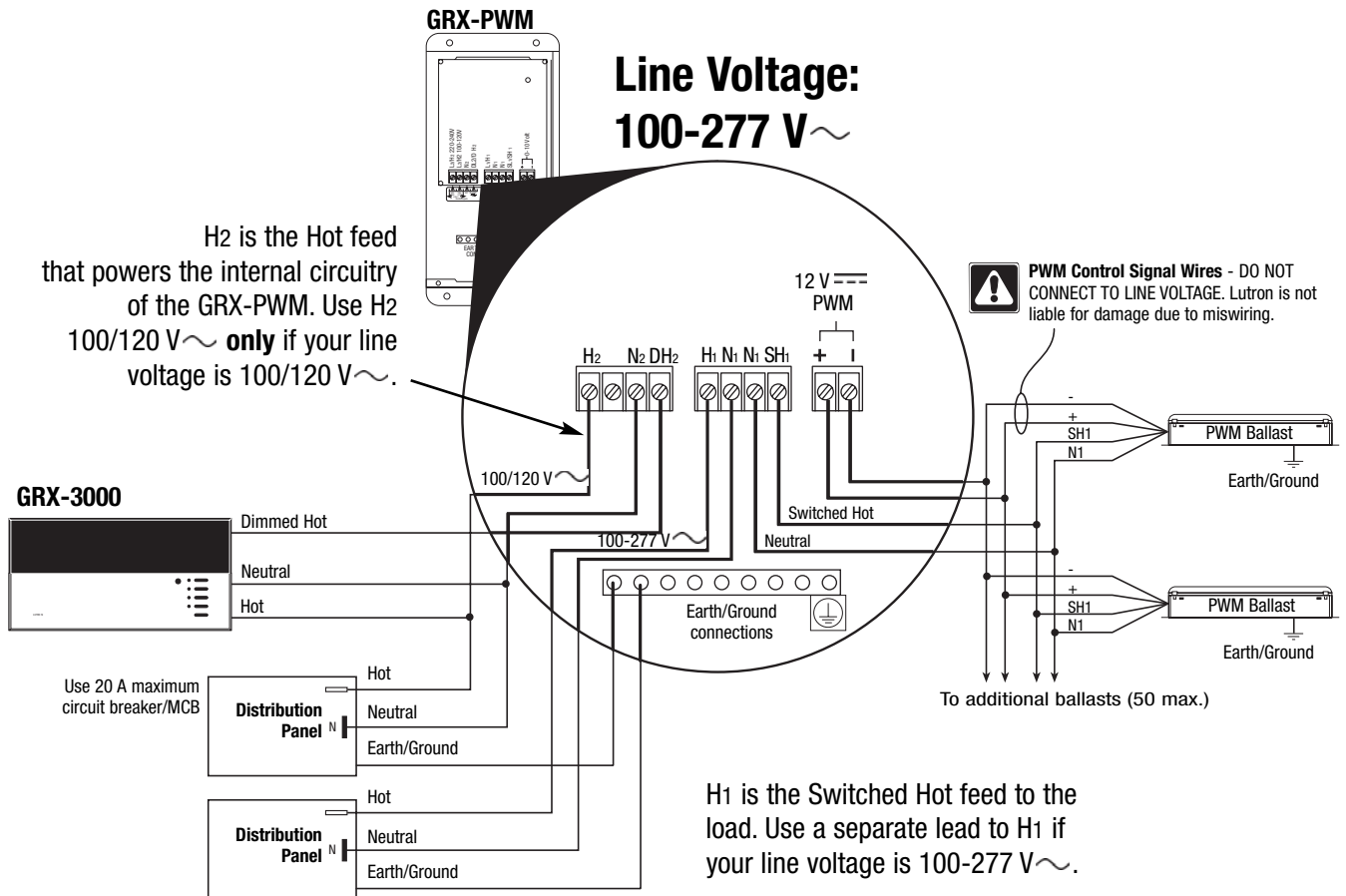

Operation

After wiring is complete, supply power to the GRX-PWM to check for proper operation.

- With the cover removed, an LED will provide visual feedback about the operation of the system.
- When power is first applied, the LED will turn on for 8 seconds to indicate start-up mode and then start to flash in one of two ways to indicate the status of the system:

1. Standard Operation

- The LED will flash at a rate of twice per second to signify proper communication between the Control Unit and the Interface.

2. Incorrect Operation - No Active Input

- The LED will repeatedly turn on for 1 second, then off for 1 second, to indicate that there is not an active phase control input to the GRX-PWM. Make sure that the phase control dimmer is ON and connected to the GRX-PWM at the terminal block marked DH2. Check that the corresponding zone for the DH2 terminal is ON and the light level is not set at the minimum output.
- When the LED indicates proper input of a phase control signal, then the output can be checked by looking at the load and checking operation from the Control Unit.
- For non-dimming ballasts, select non-dim load type on the *GRAFIK Eye* Control Unit and do not connect ballasts to PWM's + and - terminals.



Make sure that the Control Unit is set for **Fluorescent Load Type**. (Refer to *GRAFIK Eye* 3000 Series Installer's Guide.) If the load type is not set correctly, proper dimming will not occur.

Troubleshooting

Symptom	Possible Cause	Solution
PWM Ballast does not dim or control unit to the Interface.	Miswire	Verify that LED pulses twice per second. If not, check wiring from phase control unit to the Interface.
	Power is OFF	Make sure that the <i>GRAFIK Eye</i> 3000 Series Control Unit is ON.
	Miswire	Check for proper polarity of PWM signals at terminal blocks. Does it match what is at every ballast? A miswire at any ballast will cause all ballasts to go to the low end.
	Incorrect control setup	<i>GRAFIK Eye</i> 3000 Series Control Unit is not configured for fluorescent load type.
Light does not switch on	Miswire	Check that the SH1 connection goes to the ballasts.
	Miswire	Check that the DH2 connection is actually wired to a phase control input.
Light does not switch off	Miswire	Check that load is connected to SH terminal.
	Miswire	Check that the DH2 connection is actually wired to a phase control input.
LED is not illuminated	No power input	Check that power is applied to the Interface.

Internet: www.lutron.com
E-mail: product@lutron.com

WORLD HEADQUARTERS

Lutron Electronics Co., Inc.
7200 Suter Road, Coopersburg, PA 18036
TEL +1-610-282-3800
FAX +1-610-282-1243

EUROPEAN HEADQUARTERS

Lutron EA Ltd.
6 Sovereign Close, Wapping, London, E1W
3JF United Kingdom
TEL +44-207-702-0657
FAX +44-207-480-6899
FREEPHONE (UK) 0800-282-107
Technical support +44-(0)20-7680-4481

WORLDWIDE OFFICES

Brazil
Lutron BZ do Brasil Ltda.
AV, Brasil, 239, Jardim America,
Sao Paulo-SP, CEP01431-000, Brasil
TEL +55 11 3885-5152

France
Lutron LTC, S.A.R.L.
90 rue de Villiers, 92300 Levallois-Perret
France
TEL +33-(0) 1-41-05-42-80
FAX +33-(0) 1-41-05-01-80
FREEPHONE 0800-90-12-18

Germany
Lutron Electronics GmbH, Landsberger
Allee 201, 13055 Berlin, Germany
TEL +49-309-710-4590
FAX +49-309-710-4591
FREEPHONE 0800-5887 6635

Italy

Lutron LDV, S.r.l.
FREEPHONE 800-979-208

Spain, Madrid

Lutron CC, S.R.L.
Calle Orense, 85, 28020 Madrid, Spain
TEL +34-91-567-84 79
FAX +34-91-567-84 78
FREEPHONE 0900-948-944

Spain, Barcelona

Lutron CC, S.R.L.
Gran Via del Carlos III, 84, planta 3a,
08028,
Barcelona, Spain
TEL +34-93-496-57 42
FAX +34-93-496-57 01
FREEPHONE 0900-948-944

China, Beijing

Lutron GL Ltd.
5th Floor, China Life Tower, No. 16 Chaowai
Street, Chaoyang District, Beijing 100020
China
TEL +86-10-5877-1817
FAX +86-10-5877-1816

China, Shanghai

Lutron GL Ltd.
Suite 07, 39th Floor, Plaza 66,
1266 Nan Jing West Road, Shanghai,
200040 China
TEL +86-21-6288-1473
FAX +86-21-6288-1751

China, Guangzhou

Lutron GL Ltd. Guangzhou Representative
Office
Plaza Business and Conference Centre
(Guangzhou)
Suite A09, 23/F Tower A, Center Plaza,
161 LinHeXilu, Tianhe District, Guangzhou
510620 China
TEL +86-20-2885-8266
FAX +86-20-2885-8366

Hong Kong

Lutron GL Ltd.
Room 2808, 28/F, 248 Queen's Road East,
Wanchai, Hong Kong
TEL +852-2104-7733
FAX +852-2104-7633

Japan

Lutron Asuka Co. Ltd.
No. 16 Kowa Building, 4F, 1-9-20, Akasaka,
Minato-ku, Tokyo 107-0052 Japan
TEL +81-3-5575-8411
FAX +81-3-5575-8420

Singapore

Lutron GL Ltd.
6A Upper Cross Street, Singapore 058326
TEL +65-6220-4666
FAX +65-6220-4333

Asia Technical Hotlines

Northern China: 10-800-712-1536
Southern China: 10-800-120-1536
Hong Kong: 800-901-849
Singapore: 800-120-4491
Taiwan: 00-801-137-737
Thailand: 001-800-120-665853

LIMITED WARRANTY

Lutron will, at its option, repair or replace any unit that is defective in materials or manufacture within one year after purchase. For warranty service, return unit to place of purchase or mail to Lutron at 7200 Suter Rd., Coopersburg, PA 18036-1299, postage pre-paid.

This warranty is in lieu of all other express warranties, and the implied warranty of merchantability is limited to one year from purchase. This warranty does not cover the cost of installation, removal or reinstallation, or damage resulting from misuse, abuse, or improper or incorrect repair, or damage from improper wiring or installation. This warranty does not cover incidental or consequential damages. Lutron's liability on any claim for damages arising out of or in connection with the manufacture, sale, installation, delivery, or use of the unit shall never exceed the purchase price of the unit.

This warranty gives you specific legal rights, and you may also have other rights which vary from state to state. Some states do not allow limitations on how long an implied warranty lasts, so the above limitation may not apply to you. Some states do not allow the exclusion or limitation of incidental or consequential damages, so the above limitation or exclusion may not apply to you.

This product may be covered by one or more of the following U.S. Patents: 4,797,599; 5,309,068; 5,633,540; and corresponding foreign patents.

Nomex is a registered trademark of E.I. Du Pont de Nemours and Company.

Lutron, the sunburst logo, and *GRAFIK Eye* are registered trademarks; Eco-10 is a trademark of Lutron Electronics Co., Inc. © 2006 Lutron Electronics Co., Inc.



Lutron Electronics Co., Inc.
Made and printed in U.S.A. 2/06
P/N 031-267 Rev. A



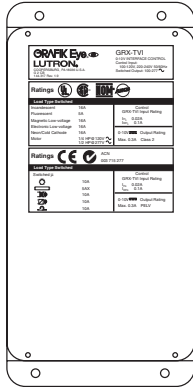

Description

The GRX-TVI provides 0-10V control and ballast switching capabilities in one enclosure. The GRX-TVI gives *GRAFIK Eye* 3000 Series Control Units the ability to control any 0-10V ballasts powered by 100V-277V (**ballast must provide 0-10V sourcing of current**) and provides switching relays that can handle the in-rush current for a circuit of ballasts. The GRX-TVI gives a *GRAFIK Eye* 3000 Series Control Unit the ability to both dim and switch electronic ballasts, such as *Lutron's Eco-10™* (TVE models). The GRX-TVI can also be used to switch any of the load types listed below.

Product Specifications

FEATURES.....Provides a Class 2/PELV isolated 0-10V output signal that conforms to EN60929 and IEC60929
Accepts a constant-gate drive fluorescent signal (100-127V, 220-240V, 50/60Hz)

INPUT POWER RATING.....100-127/220-240V, 50/60Hz

H2/L2 TERMINAL.....20mA

INPUT RATING

DH2/DL2 TERMINAL.....100mA

INPUT RATING

0-10V OUTPUT RATING.....10µA-300mA - Sinks current only (maximum 150 ballasts)

Source/Load Type	230V (CE)	100-127V/ 200-277V
Fluorescent: <i>Lutron Eco-10™</i> (TVE Series)	—	16A
Electronic Capacitive Non-Dim	10A	16A
Other Manufacturer's 0-10V Ballasts (0-10V source only)	10A	16A
Incandescent	10A	16A
Low-Voltage	10A	16A
Metal Halide	10A	16A
Neon/Cold Cathode	10A	16A
Motors	1/4HP @ 100-120V 1/2HP @ 200-277V 1/2HP @ 230V CE	

TERMINALS Two #12-20AWG (0.5-2.5 mm²) conductors per terminal.

MOUNTING NEMA Type 1 enclosure, indoor use only.

ENVIRONMENTAL 32—104 °F (0—40 °C).

WEIGHT 4.25 lb. (2kg)

Mounting

Find a suitable location for mounting.

- Decide on the proper location for the GRX-TVI (NEMA Type 1 enclosure, indoor use only). See System Wiring Layout below.
- The environment where the GRX-TVI is placed must have an ambient temperature range of 32—104 °F (0—40 °C).
- Mount the enclosure vertically on a wall (screws not provided). See Mounting Diagram below.
- Mounting method must be able to support weight and forces applied during installation.
- Internal relays will click while in operation — mount where audible noise is acceptable.

System Wiring Layout

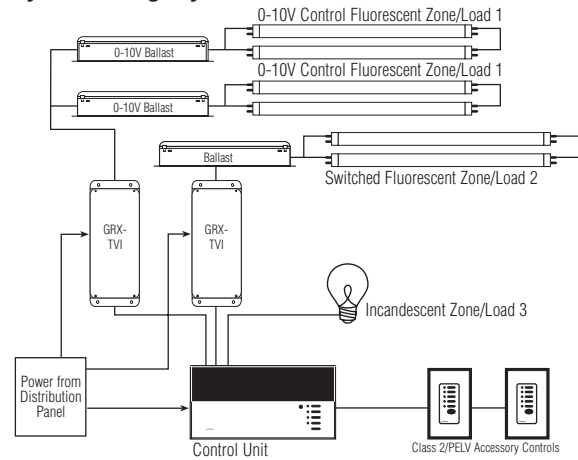

Note: When using a Control Unit, a GRX-TVI is required for each 0-10V fluorescent zone. (A 3-zone Control Unit with two fluorescent zones and one incandescent zone is shown as an example.)

Mounting Diagram

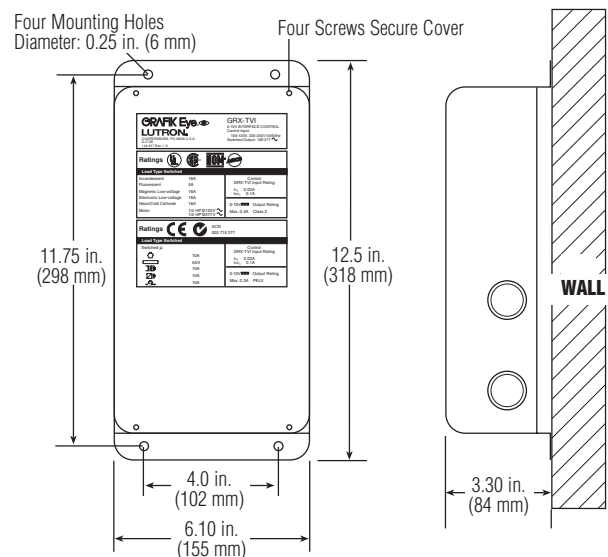

220-240V/CE Control Interface

Important Installation Information

- Install in accordance with all national and local electrical codes.
- Check for short circuited loads during new installations before wiring the GRX-TVI.



Caution: Multiple feeds may enter this enclosure. Locate and lock each feed circuit breaker/MCB in the OFF position before wiring the Interface.

- Proper short circuit and overload protection must be provided at the distribution panel. You can use up to a 20A (16A for CE) maximum circuit breaker/MCB or equivalent (tripping curve C according to IEC 898/EN60898 is recommended) with adequate short circuit breaking capacity for your installation.
- Terminal blocks are rated for two #12-22 AWG (0.5-2.5 mm²) wires per terminal.
- Strip 3/8 in. (10 mm) of insulation from wires.
- Wiring Diagram A shows a GRX-TVI wired from one distribution panel. If the power requirement of the complete system is less than an MCB/circuit breaker rating, one feed can be jumpered inside the enclosure (as shown).
- Wiring Diagram B shows a GRX-TVI wired from two separate distribution panels that may be different phases or voltages.
- Use the internal terminal block label to see where to land wires.

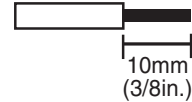

- The label shows two separate Hot/Live terminals (L1/H1 & L2/H2).
L1/H1 is the Hot/Live feed to power the lighting load.
L2/H2 is the Hot/Live feed that powers internal circuitry of the GRX-TVI.
*L2/H2 has a 100-127V connection **and** a 220-240V connection - use **only** the one corresponding to line voltage for your application.*

Note 1: Not all terminal blocks receive a connection.

Note 2: The power feed to the Control Unit and L2/H2 of the GRX-TVI must be the same phase!
Class 2/PELV, 0-10V wiring from a ballast to the GRX-TVI-CE must be separated from the power wiring. Enter the Class 2/PELV wires through the knockout adjacent to the 0-10V terminal blocks. The Nomex[®] barrier ensures separation and is flexible to allow access to the terminals. The barrier must be in place when installation is complete.

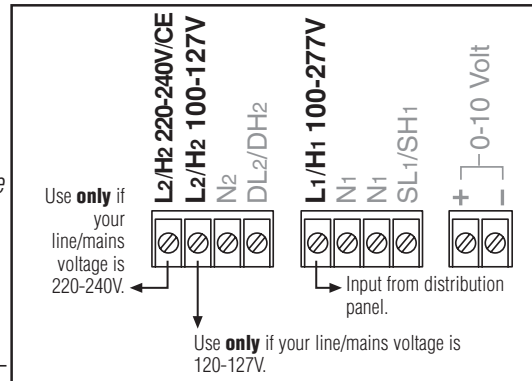

GRX-TVI Internal Terminal Block Label Definitions

Use **only one** input according to Input Voltage:

L2/H2 240V	Power input for GRX-TVI control (line/mains voltage must be 220-240V)
L2/H2 127V	Power input for GRX-TVI control (line/mains voltage must be 100-127V)
N2	Neutral for GRX-TVI control
DL2/DH	GRAFIK Eye 3000 Series Control Unit Lighting Zone connection (Phase Control Input to GRX-TVI)
L1/H1	Power input for lighting load
N1	Neutral for lighting load (2 terminals provided and internally tied together — one for input neutral and one for load neutral)
SL1/SH1	Switched output to power lighting load
+ -	0-10V control signal wires (ballast must provide a 0-10V source only)

Wiring Diagram A: 220-240V/CE GRX-TVI — 1 Distribution Panel

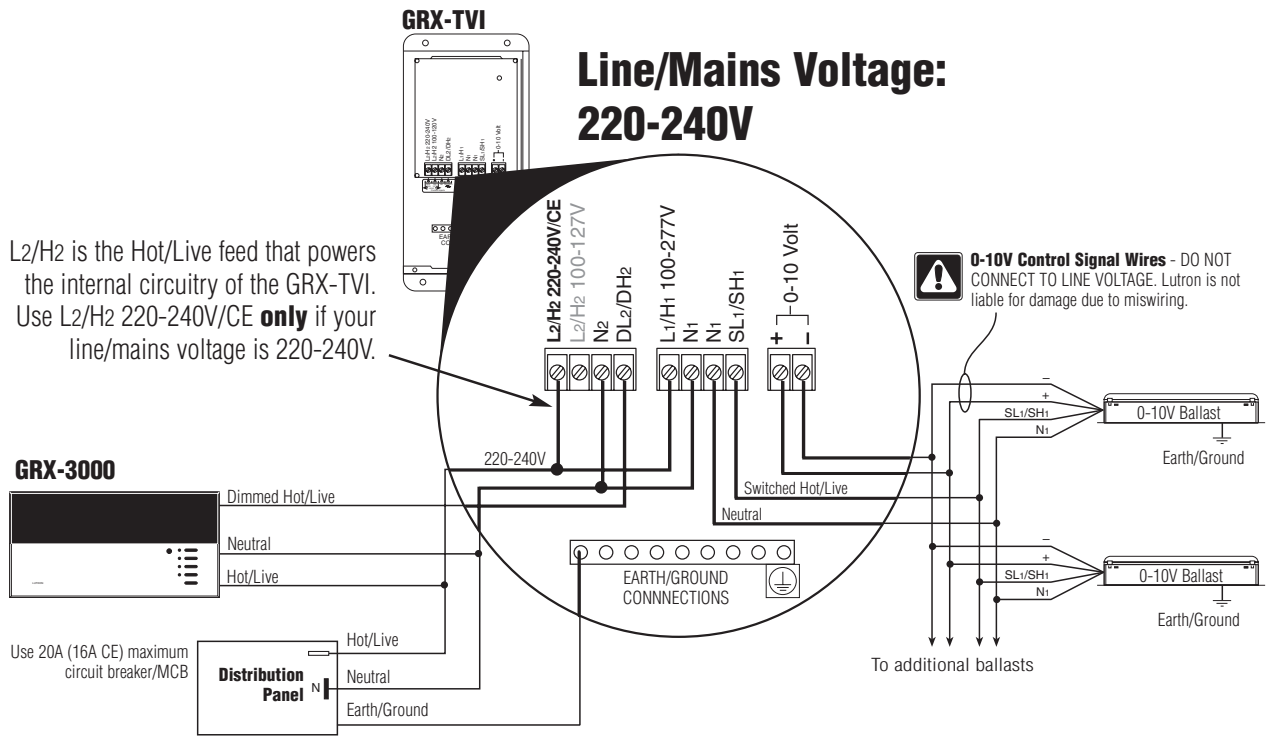

Wiring Diagram B: 220-240V/CE GRX-TVI — 2 Distribution Panels

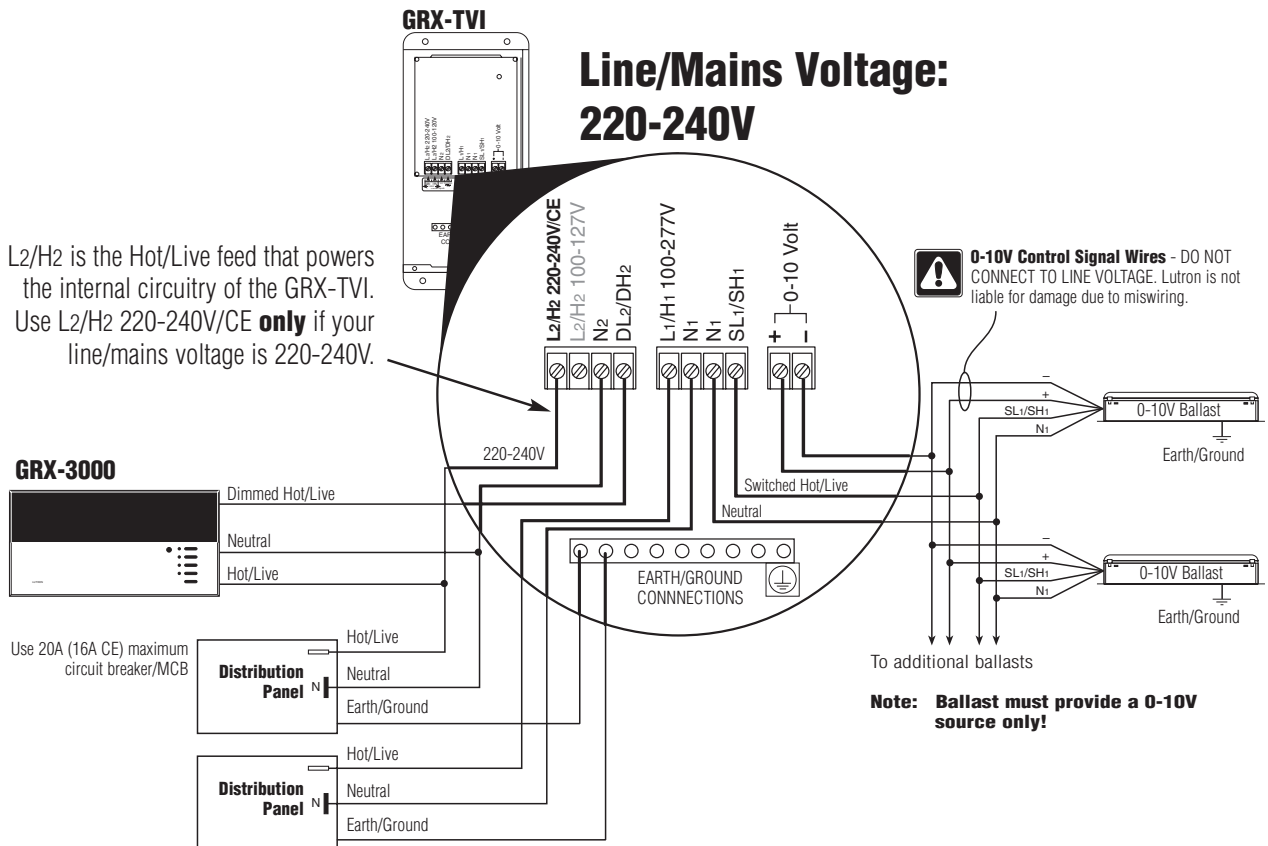

100-127V Control Interface

Important Installation Information

- Install in accordance with all national and local electrical codes.
- Check for short circuited loads during new installations before wiring the GRX-TVI.



Caution: Multiple feeds may enter this enclosure. Locate and lock each feed circuit breaker/MCB in the OFF position before wiring the Interface.

- Proper short circuit and overload protection must be provided at the distribution panel. You can use up to a 20A (16A for CE) maximum circuit breaker/MCB or equivalent (tripping curve C according to IEC 898/EN60898 is recommended) with adequate short circuit breaking capacity for your installation.
- Terminal blocks are rated for two #12-22 AWG (0.5-2.5 mm²) wires per terminal.
- Strip 3/8 in. (10 mm) of insulation from wires.
- Wiring Diagram C shows a GRX-TVI wired from one distribution panel. If the power requirement of the complete system is less than an MCB/circuit breaker rating, one feed can be jumpered inside the enclosure (as shown).
- Wiring Diagram D shows a GRX-TVI wired from two separate distribution panels that may be different phases or voltages.
- Use the internal terminal block label to see where to land wires.

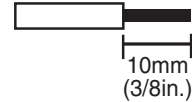

- The label shows two separate Hot/Live terminals (L1/H1 & L2/H2).
L1/H1 is the Hot/Live feed to power the lighting load.
L2/H2 is the Hot/Live feed that powers internal circuitry of the GRX-TVI.

*L2/H2 has a 100-127V connection **and** a 220-240V connection - use **only** the one corresponding to line voltage for your application.*

Note 1: Not all terminal blocks receive a connection.

Note 2: The power feed to the Control Unit and L2/H2 of the GRX-TVI must be the same phase!
Class 2/PELV, 0-10V wiring from a ballast to the GRX-TVI-CE must be separated from the power wiring. Enter the Class 2/PELV wires through the knockout adjacent to the 0-10V terminal blocks. The *Nomex*® barrier ensures separation and is flexible to allow access to the terminals. The barrier must be in place when installation is complete.

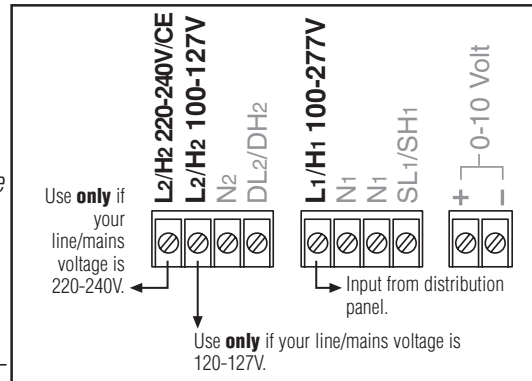

GRX-TVI Internal Terminal Block Label Definitions

Use **only one** input according to Input Voltage:

L2/H2 240V	Power input for GRX-TVI control (line/mains voltage must be 220-240V)
L2/H2 127V	Power input for GRX-TVI control (line/mains voltage must be 100-127V)
N2	Neutral for GRX-TVI control
DL2/DH	GRAFIK Eye 3000 Series Control Unit Lighting Zone connection (Phase Control Input to GRX-TVI)
L1/H1	Power input for lighting load
N1	Neutral for lighting load (2 terminals provided and internally tied together — one for input neutral and one for load neutral)
SL1/SH1	Switched output to power lighting load
+ -	0-10V control signal wires (ballast must provide a 0-10V source only)

Wiring Diagram C: 100-127V GRX-TVI — 1 Distribution Panel

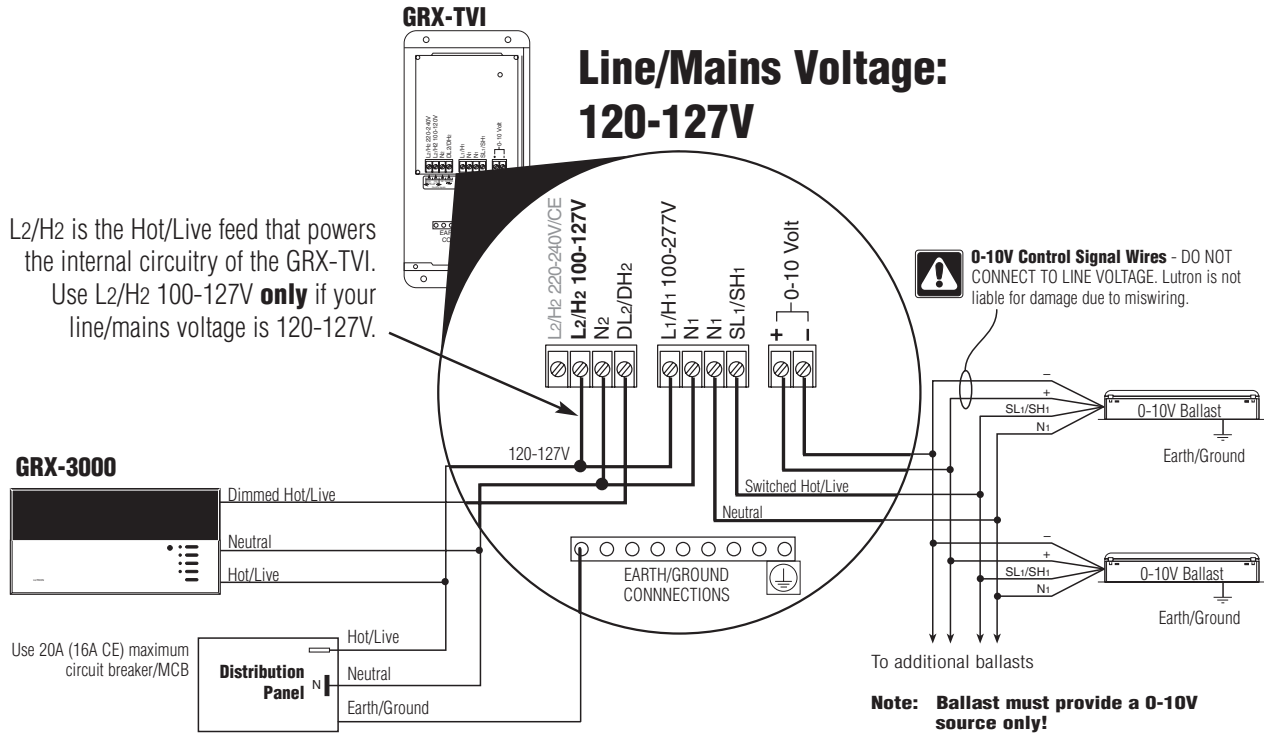

Wiring Diagram D: 100-127V GRX-TVI — 2 Distribution Panels

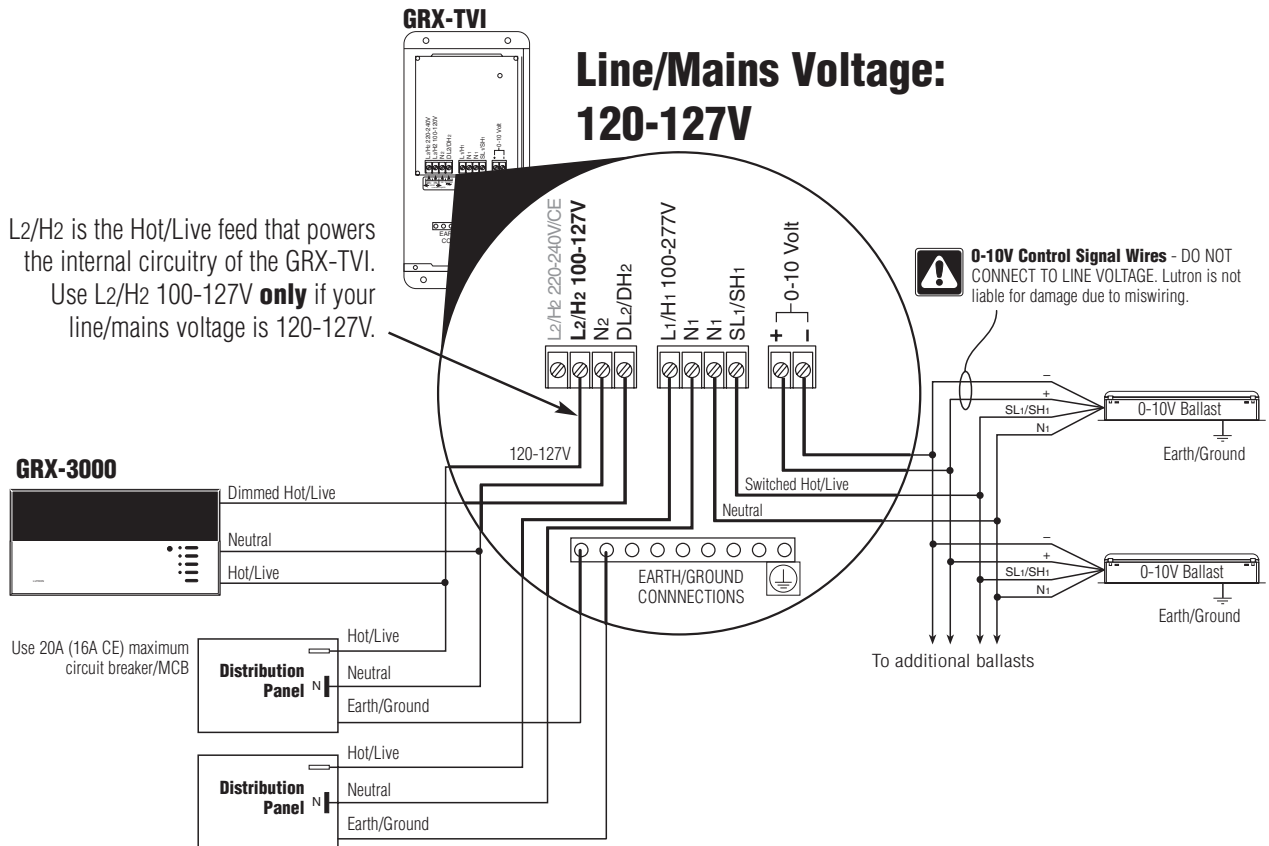

Operation

After wiring is complete, supply power to the GRX-TVI to check for proper operation.

- With the cover removed, an LED will provide visual feedback about the operation of the system.
- When power is first applied, the LED will turn on for 8 seconds to indicate start-up mode and then start to flash in one of two ways to indicate the status of the system:
 1. **Standard Operation**
 - The LED will flash at a rate of twice per second to signify proper communication between the Control Unit and the Interface.
 2. **Incorrect Operation - No Active Input**
 - The LED will repeatedly turn on for 1 second then off for 1 second to indicate that there is not an active phase control input to the GRX-TVI. Make sure that the phase control dimmer is ON and connected to the GRX-TVI at the terminal block marked DL2/DH2. Check that the corresponding zone for the DL2/DH2 terminal is ON and the light level is not set at the minimum output.
- When the LED indicates proper input of a phase control signal, then the output can be checked by looking at the load and checking operation from the Control Unit.
- For non-dimming ballasts, select non-dim load type on the GRAFIK Eye Control Unit and do not connect ballasts to 0-10V terminals.



Make sure that the Control Unit is set for **Fluorescent Load Type**. (Refer to *GRAFIK Eye 3000 Series Installer's Guide*.) If the load type is not set correctly, proper dimming will not occur.

Troubleshooting

Symptom	Possible Cause	Solution
0-10V Ballast does not dim or control unit to the Interface.	Miswire	Verify that LED pulses twice per second. If not, check wiring from phase control unit to the Interface.
	Power is OFF	Make sure that the <i>GRAFIK Eye 3000 Series Control Unit</i> is ON.
	Miswire	Check for proper polarity of 0-10V signals at terminal blocks. Does it match what is at every ballast? A miswire at any ballast will cause all ballasts to go to the low end.
	Incorrect Control Setup	<i>GRAFIK Eye 3000 Series Control Unit</i> is not configured for fluorescent load type.
Light does not switch on	Miswire	Check that the SL ₁ /SH ₁ connection goes to the ballasts.
	Miswire	Check that the DL ₂ /DH ₂ connection is actually wired to a phase control input.
Light does not switch off	Miswire	Load is not connected to SH (SL) terminal.
	Miswire	Check that the DL ₂ /DH ₂ connection is actually wired to a phase control input.
LED is not illuminated	No Power Input	Check that power is applied to the Interface.

Internet: www.lutron.com
E-mail: product@lutron.com

WORLD HEADQUARTERS
Lutron Electronics Co. Inc.,
TOLL FREE: (800) 523-9466
(U.S.A., Canada, Caribbean)
Tel: (610) 282-3800;
International +1- 610-282-3800
Fax: (610) 282-1243;
International +1-610-282-1243

EUROPEAN HEADQUARTERS
Lutron EA Ltd.,
Tel: (207) 702-0657;
International +44-207-702-0657
Fax: (207) 480-6899;
International +44-207-480-6899

GERMANY
Lutron Electronics GmbH
Tel: (309) 710-4590;
International +49-309-710-4590
Fax: (309) 710-4591;
International +49-309-710-4591

FRANCE
Lutron LTC
International +33-1-44-70-72-00
Int'l Fax: +33-1-44-70-00-19

ASIAN HEADQUARTERS
Lutron Asuka Corporation (Japan)
Tel:(03)-5575-8411;
International (03)-5575-8411
Fax: +(03) -5575-8420;
International +81-3-5575-8420

HONG KONG SALES OFFICE
Lutron GL (Hong Kong)
Tel: 2104-7733;
International +852-2104-7733
Fax: 2104-7633;
International +852-2104-7633

SINGAPORE
Lutron GL (Singapore)
Tel: +65-6220-4666
Fax: +65-6220-4333

LIMITED WARRANTY

Lutron will, at its option, repair or replace any unit that is defective in materials or manufacture within one year after purchase. For warranty service, return unit to place of purchase or mail to Lutron at 7200 Suter Rd., Coopersburg, PA 18036-1299, postage pre-paid.

This warranty is in lieu of all other express warranties, and the implied warranty of merchantability is limited to one year from purchase. This warranty does not cover the cost of installation, removal or reinstallation, or damage resulting from misuse, abuse, or improper or incorrect repair, or damage from improper wiring or installation. This warranty does not cover incidental or consequential damages. Lutron's liability on any claim for damages arising out of or in connection with the manufacture, sale, installation, delivery, or use of the unit shall never exceed the purchase price of the unit.

This warranty gives you specific legal rights, and you may also have other rights which vary from state to state. Some states do not allow limitations on how long an implied warranty lasts, so the above limitation may not apply to you. Some states do not allow the exclusion or limitation of incidental or consequential damages, so the above limitation or exclusion may not apply to you.

Nomex is a registered trademark of E.I. Du Pont de Nemours and Company.
Lutron and *GRAFIK Eye* are registered trademarks; *Eco-10* is a trademark of Lutron Electronics Co., Inc.

© 2003 Lutron Electronics Co., Inc.

LUTRON®

Lutron Electronics Co., Inc.
Made and printed in U.S.A. 8/03
P/N 032-119 Rev. B

Hi-POWER 2•4•6™

Installation Instructions
Please Leave for Occupant

HP-2, HP-4, & HP-6
Dimming Module
120/277VAC, 60Hz

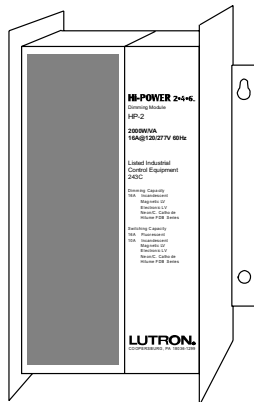

Description

The Hi-POWER 2•4•6 Dimming Module provides the capability to control a large zone of lighting from either a Lutron incandescent wallbox dimmer or from Class 2 controls. Multiple modules can be used together in a system to control a total load of up to 30,000W/VA. The Hi-POWER 2•4•6 Dimming Module can dim 120V incandescent, magnetic low-voltage, electronic low-voltage, neon/cold-cathode loads, 277V magnetic low-voltage, and Lutron's Hi-lume® FDB-series and Eco-10™, 120V and 277V fluorescent dimming ballasts. It can also switch these loads (except Hi-lume FDB and Eco-10 ballasts) as well as metal halide and non-capacitive fluorescent loads.

Important Notes

Please Read Before Installation

1. Install in accordance with all local and national electrical codes.
2. **CAUTION:** Only a qualified electrician should install this system. Turn power OFF at circuit breakers or remove fuses before wiring. Do not wire with power on. Improper wiring can result in personal injury or damage to equipment. Damage to product caused by wiring with power on voids warranty.
3. Do not remove factory-installed bypass jumpers on load circuit terminals until load circuits are tested (see Start-up Procedure on page 5).
4. The Hi-POWER dimming modules are designed to operate in ambient temperatures between 0°C-40°C (32°F-104°F).
5. To reduce the risk of overheating and possible damage to other equipment, the module must be mounted as shown on page 2. Failure to provide adequate space for cooling may result in overheating and void the warranty.

6. Module hums slightly during operation and the internal relay clicks when the circuit is turned on and off. Choose an installation location where these sounds are acceptable.
7. Operation of dimmed low-voltage circuit with all lamps inoperative or removed may result in current flow in excess of normal levels. To avoid transformer overheating and possible failure, Lutron strongly recommends the following:
 - a. Do not operate dimmed low-voltage circuits without lamps in place.
 - b. Replace burned-out lamps immediately.
 - c. Use transformers incorporating thermal protection or fused transformer primary windings to prevent transformer failure due to overcurrent.
8. Dimmed electronic low-voltage transformers may produce an audible noise when dimmed. For more information, call the toll-free **Lutron Hotline** at 1-800-523-9466.
9. See "Neon/Cold-Cathode Dimming" (pages 14-15) before attempting to dim neon/cold-cathode lamps.
10. For proper dimming performance fluorescent lamps must be operated at full intensity for 100 hours prior to dimming.

Electrical Ratings

Module		HP-2	HP-4	HP-6
Inputs Required	Control Circuit 120VAC, 60Hz	1 (20VA)	1 (20VA)	1 (20VA)
	Load Circuit 120/277 ^{1,4} VAC, 60Hz	1	2	3
Outputs Available	Dimmed Hot	1	2	3
	Switched Hot	1	2	3
Minimum load per Module	Hi-lume FDB or Eco-10 ballasts	1	2	3
	All other loads	50W/VA	100W/VA	150W/VA
Heat Dissipation	BTU/Hr Maximum	200	400	600

Capacity of each Output^{2,3}

Load Type	Dimmed	Switched ⁴
Incandescent	16A (1920W)	10A
Magnetic Low-Voltage, Electronic Low-Voltage, or Neon/Cold-Cathode	16A (1920VA)	10A
Hi-lume FDB or Eco-10 Fluorescent	16A	—
Fluorescent (non-capacitive)	—	16A
Metal Halide	—	10A

¹ 277V Hi-lume FDB or Eco-10 fluorescent, or 277V magnetic low-voltage only.

² Any load circuit can be connected to any phase.

³ Each load circuit may be connected to a different load type; however, load types cannot be mixed on the same circuit.

⁴ Switched loads may be either 120 or 277VAC.

LUTRON®

These products may be covered by one or more of the following U.S. patents: 4,797,599; 4,803,380; 4,893,062; 4,947,054; 5,030,893; 5,191,265; 5,248,919; 5,399,940; 5,430,356; 5,463,286; DES 311,170; DES 313,738; DES 337,755; DES 399,326; DES 344,264; DES 353,798 and corresponding foreign patents. U.S. and foreign patents pending. Lutron, GRAFIK Eye, Hi-lume, Maestro, Nova T™, and Vareo are registered trademarks and Hi-POWER 2•4•6, ECO-10, and Omnislide are trademarks of Lutron Electronics Co., Inc. © 1996 Lutron Electronics Co., Inc.

Mounting and Dimensions

- 1. Choose an appropriate location.**
Select a convenient location such as an electrical closet or basement. Make sure location is at least 6' from sensitive equipment (and its wiring). Also, make sure to locate module where its sounds (relays clicking and slight humming) are acceptable. Ensure ambient temperatures are between 0°C-40°C (32°F-104°F). Module must be mounted away from steam pipes, direct sunlight, or other heat sources.
- 2. Plan placement of modules (see below).**
Modules must be mounted vertically. Make sure nothing blocks the air channel between the back of the module and the wall.
 - Leave 6" (152mm) of space above and below modules and 3" (76mm) of space on either side of modules.
 - Leave 10" (204mm) between the top of the module and the ceiling, and 6" (152mm) between the bottom of the module and the floor.
 - Leave 6" (152mm) of clearance in front of each module.

Airspace Required

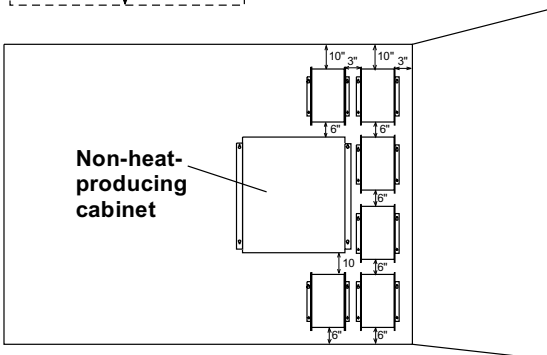
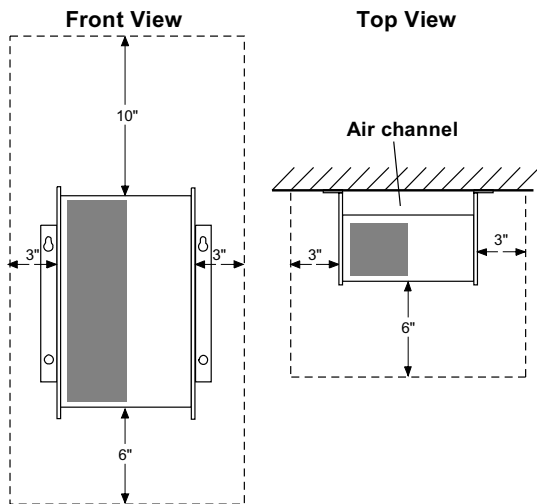

- 3. Mount modules (see below).**
Using the mounting dimensions shown below, mark (while keeping the module vertical), then drill mounting holes. Securely fasten the module to the wall. Mounting holes are keyed to facilitate mounting.

Mounting Dimensions

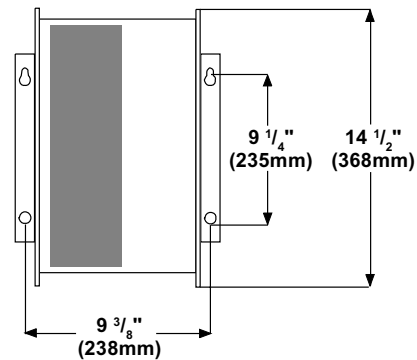

Knockout Locations

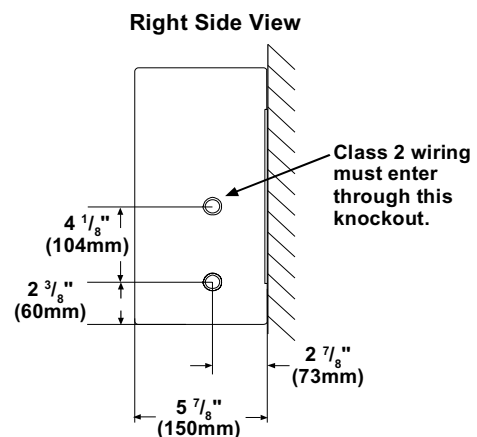
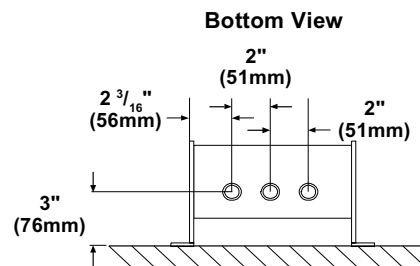

Wiring



WARNING: Turn power OFF to all circuits before installing any part of the Dimming System. Wiring with the power on can result in serious personal injury or damage to equipment.

1. Pull dedicated feeds.

For each circuit in the Hi-POWER module, pull a 20A dedicated feed: one circuit for the HP-2, two circuits for the HP-4, and three circuits for the HP-6 (see Typical System Wiring Diagram).

2. Provide control circuit power to first module.

The Hi-POWER module requires power to operate its circuitry. This control circuit can be wired from any of the dedicated feeds coming into the Hi-POWER module as long as they have an additional 20VA of capacity available for each Hi-Power module connected to the same control (refer to Power Feed Wiring Diagram on page 4 for terminal locations). Do not wire control circuit power to any additional modules.



IMPORTANT: If more than one module is used, only connect power to the control circuit of the first module.

3. Wire between Hi-POWER modules.

If more than one Dimming Module is being operated from the same control, run 3 #12 wires from the Additional Module Terminals on the first module to the Additional Module Terminals on the next. No connection is made to the Control Circuit Terminals on the additional modules. Wire additional modules until all are connected in a line. See Power Feed Wiring Diagram on page 4 for location of the Additional Module Terminals. Wiring is 1 to 1, 2 to 2, 3 to 3. Do not cross wires.

Typical System Wiring Diagram

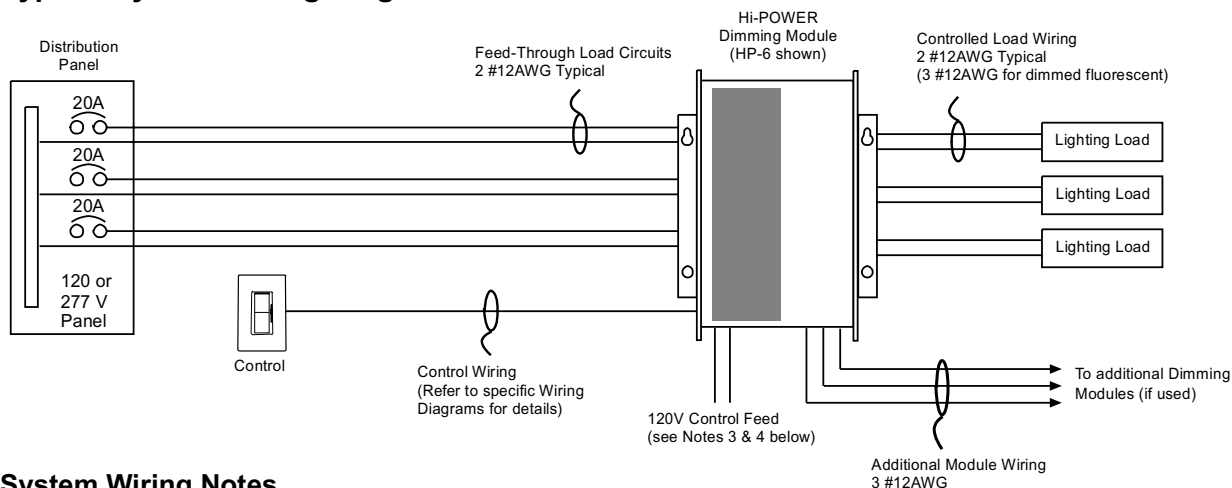

System Wiring Notes

1. Load circuit input feeds can be connected to any phase.
2. Power and control wires must be run in separate raceways. Run individual neutrals for each input and load circuit.
3. Module requires a 120V control circuit input feed. It can be provided from any source, such as one of the load circuits, with 20VA of spare capacity for each Hi-POWER module in the system (For GRAFIK Eye 3000, the control circuit feed must be on same phase as the power for the GRAFIK Eye Control Unit.) If necessary, a 277:120V, 100VA transformer may be used to obtain proper input. (Examples are Acme #TA-2-81303, Hammond Mfg. #MH100GP, or equivalents.)
4. In systems with more than one dimming module per lighting zone, connect feed to control circuit of first module only. **Control circuits must be 120V only.**
5. The diagram represents a three load circuit model (HP-6). For one circuit (HP-2) or two circuit (HP-4) applications, the number of circuits controlled differs, but the wiring will be the same. A different load type may be used on each circuit if desired. However, do not mix load types on the same load circuit.
6. 15A circuit breakers may be used in place of 20A circuit breakers. Do not exceed 1440W per 15A circuit.

4. Wire to Controlled Loads.

Load wiring differs depending on the load type and whether the load is dimmed or switched (see below). Refer to Load Wiring Diagrams on page 7 for load wiring specifics.

Load Type	Load Wiring Diagram	
	Dimmed	Switched
Incandescent	1	3
Magnetic Low-Voltage	1	3
Electronic Low-Voltage	1	3
Neon/Cold-Cathode	1	3
Hi-lume FDB	2	—
Eco-10	2	—
Fluorescent (non-capacitive)	—	3
Metal Halide	—	3



NOTE: Electronic and magnetic low-voltage transformers may create an audible noise when connected to a dimmer.

5. Wire to Controls.

Control wiring will vary depending on the type of control being used. Refer to the appropriate page for the necessary control wiring:

Control Type	Control Wiring Diagram	Page
Single-pole dimmer*	1	8
Mechanical 3-way dimmer*	2-4	8
Maestro	5-7	9
Vareo	8-10	10
Nova T* Infrared	11	11
Nova T* Omnislide	12	11
GRAFIK Eye 3000	13	11
Class 2 Control (raise/lower)	14	12-13

* Rotary, Glyder, Ariadni, Skylark, Diva, Luméa, Nova T* Slide-to-Off, Nova T* Preset, Nova Slide-to-Off, Nova Preset, Centurion, and Athena.

6. Start-up system.

Go to Start-up Procedure on page 5 to put the dimming system in operation.

Power Feed Wiring Diagram

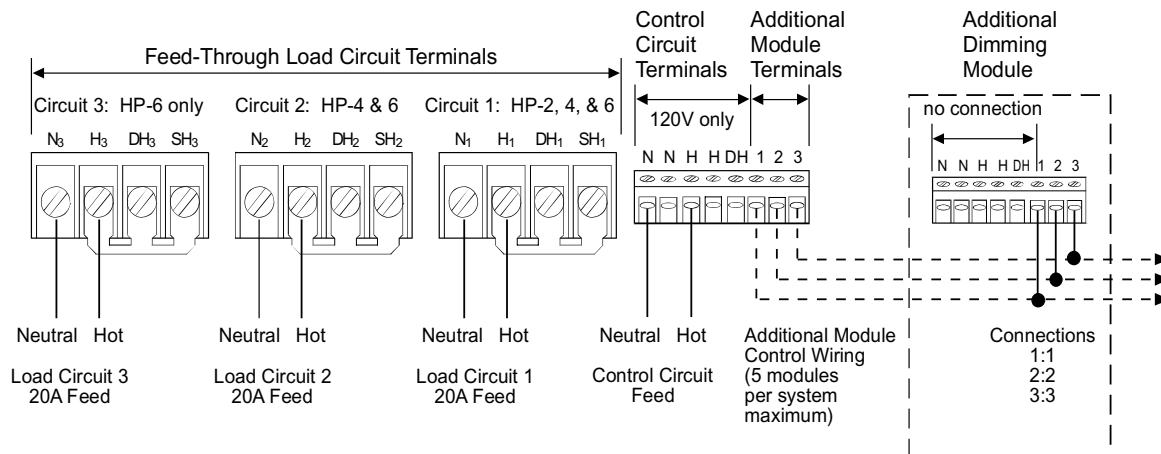
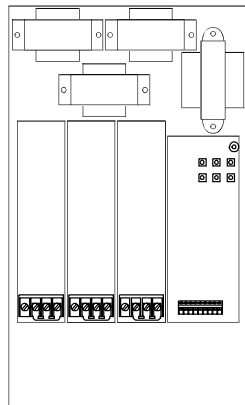

Start-up Procedure

Check Load Circuits.

1. Make sure the factory-installed bypass jumper(s) are still in place between the H (Hot), SH (Switched Hot), and DH (Dimmed Hot) terminals of each load circuit. Replace module cover. Turn circuit breakers on for each load circuit (1 circuit for HP-2, 2 circuits for HP-4, and 3 circuits for HP-6). Each Load Circuit Indicator Light inside the dimming module should light to full intensity.
2. Check the input current to the Hot terminal of each load circuit with a "clamp-on" type current probe. The current should be no more than 16A for dimmed loads or 10A for switched loads (16A for non-capacitive fluorescent). See diagram.
3. Turn loads ON for at least 10 minutes. If any circuit breaker trips, turn power OFF, then locate and correct miswire or overload.
4. Repeat the above steps until the circuit breaker does not trip. If the Hi-POWER module is controlled by a line voltage dimmer, proceed to Check Control Circuit section (next column). If the module is controlled by Class 2 controls, proceed to "Remove Bypass Jumpers" (next column).

Check Control Circuit (line-voltage dimmer only).

1. With power OFF, make sure all control wiring is correct. Replace module cover. Turn circuit breakers ON for each load circuit (one circuit for HP-2, two circuits for HP-4, and three circuits for HP-6) and the control circuit (if wired from a different breaker). Additional dimming modules should not have any wires connected to the control circuit terminals. Each system (circuit and modules) should have only one control circuit wired.

Load Circuit Testing

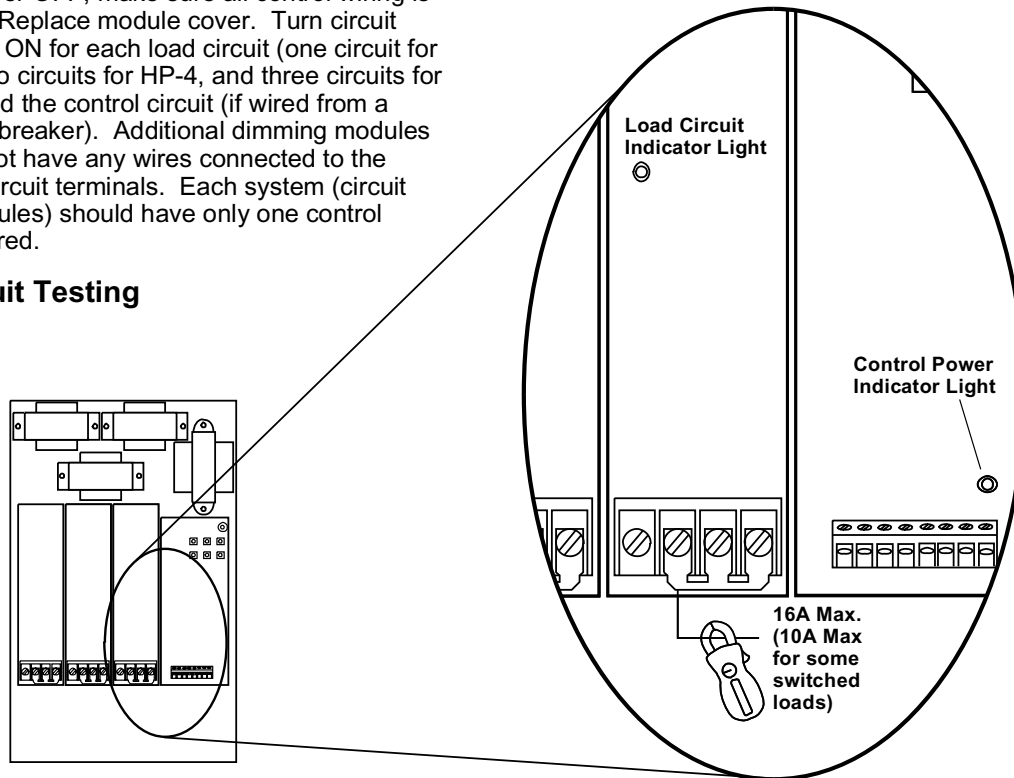

2. Adjust slider/knob/rocker on control, then switch control on and off. The lighting should remain on full, but the control power indicator light should dim up and down and/or switch on or off as the control is adjusted. Make sure the Load Circuit Indicator Lights are not dimming or switching on or off with the control. If they are, control and load wiring are incorrect. Correct wiring errors and repeat Start-up Procedure.

Remove Bypass Jumpers.

1. Turn power OFF. Make sure to remove power from all circuits providing power to the Hi-POWER dimming module.
2. Remove the load circuit bypass jumper(s) from all modules. Do not remove factory-installed jumper from Class 2 terminal block when using Lutron NTRCS-1, NRCS-1, and RCS-1 controls. See wiring diagram on pages 12-13 for details.
3. Turn power ON to all circuits. Test the control(s) to make sure they adjust the light level. The system should now function properly. If not, refer to the Troubleshooting section on page 16.
4. Proceed to Calibration on page 6.

Calibration

High-End and Low-End Trim Adjustment

The high-end and low-end light levels are adjustable to get the best dimming range for the particular application and load type.

- **For Lutron Hi-lume or ECO-10 fluorescent loads:** This unit is factory-calibrated and does not require low-end light adjustment. If lamps flicker or drop out at minimum dimming level there may be an installation error. Continued use of the system in this mode will cause premature lamp failure. If this is occurring, call the **Lutron Hotline** at 1-800-523-9466. For proper dimming performance fluorescent lamps must be operated at full intensity for 100 hours.
- **For incandescent, magnetic low-voltage, and electronic low-voltage loads:** Some adjustment will be necessary to achieve full-range dimming.
- **For neon/cold-cathode loads:** Depending on the installation, you may be able to achieve a lower dimming range. The low-end should be adjusted so that no flickering occurs or the transformer may fail prematurely.

Control Adjustment: Line-voltage incandescent dimmer

CAUTION: For all adjustments, use the supplied non-conductive probe. Failure to do so can result in personal injury or damage to equipment. Do not use screwdriver or finger.

High-End Trim

1. Adjust the wall control to its full intensity position.
2. Using the non-conductive probe, push the small buttons labeled “RAISE” or “LOWER” (see diagram at right) to make the high-end light level brighter or dimmer.
3. Repeat for each load circuit as necessary.

Low-End Trim

1. Adjust the wall control to its minimum position.
2. Using the non-conductive probe, push the small buttons labeled “RAISE” or “LOWER” (see diagram at right) to make the low-end light level brighter or dimmer.
3. Repeat for each load circuit as necessary.

Control Adjustment: Class 2 Raise/Lower

CAUTION: For all adjustments, use the supplied non-conductive probe. Failure to do so can result in personal injury or damage to equipment. Do not use screwdriver or finger.

High-End Trim

1. Using the non-conductive probe, turn the Fade Rate Adjust (see figure below) fully counterclockwise.
2. Activate the raise function on the control for 10 seconds to bring the lights to their maximum intensity.
3. Using the non-conductive probe, push the small buttons labeled “RAISE” or “LOWER” (see figure below) to make the high end light level brighter or dimmer.
4. Repeat for each load circuit as necessary.

Low-End Trim

1. Using the non-conductive probe, turn the Fade Rate Adjust (see figure below) fully counterclockwise.
2. Activate the lower function on the control for 10 seconds to bring the lights to their minimum intensity.
3. Using the non-conductive probe, push the small buttons labeled “RAISE” or “LOWER” to make the low-end light level brighter or dimmer.
4. Repeat for each load circuit as necessary.

Fade Rate Adjustment (Class 2 controls only)

The fade rate is the time it takes for the lights to go from the lowest to highest intensity (or vice-versa) when activating a Class 2 wired raise/lower control. If you are using Class 2 wired NTRCS-1, NRCS-1, or RCS-1 multi-location wall controls, the Hi-POWER module is factory preset to the fastest fade rate. The fade rate can be changed in increments of approximately 2, 4, 8, 15, 30, and 60 seconds. Use the non-conductive probe to turn the Fade Rate Adjust (see figure below) clockwise to fade faster or counterclockwise to fade slower.

Intensity and Fade Adjust Location

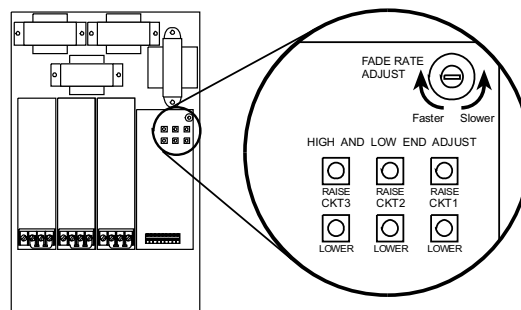

Load Wiring

Diagram 1

Dimmed loads:

Incandescent, Magnetic Low-Voltage, Electronic Low-Voltage, Neon/Cold-Cathode

Wiring notes:

1. For Neon/Cold-Cathode loads, refer to pages 14 and 15 for proper installation.
2. Terminal blocks are rated for 2 #12 AWG max.
3. Load wiring must be 120VAC.
4. The diagrams represent a single load circuit model (HP-2). For two circuit (HP-4) or three circuit (HP-6) applications, repeat the same wiring method for each circuit. A different load type may be used on each circuit if desired. However, do not mix load types on the same load circuit.

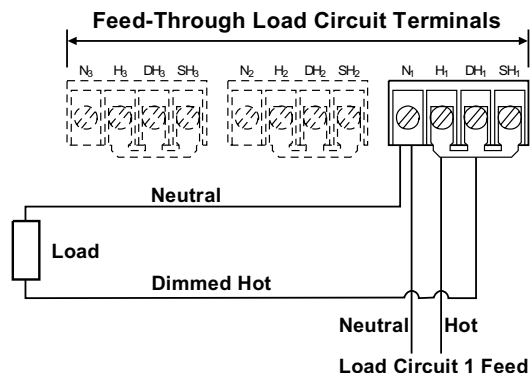

Diagram 2

Dimmed Loads:

Hi-lume FDB and Eco-10 Fluorescent Dimming Ballasts

Wiring notes:

1. Use only Lutron Hi-lume or Eco-10 Fluorescent Dimming Ballasts.
2. Terminal blocks are rated for 2 #12 AWG max.
3. Load wiring may be 120VAC or 277VAC. Control circuit must be 120VAC.
4. The diagrams represent a single load circuit model (HP-2). For two circuit (HP-4) or three circuit (HP-6) applications, repeat the same wiring method for each circuit. A different load type may be used on each circuit if desired. However, do not mix load types on the same load circuit.

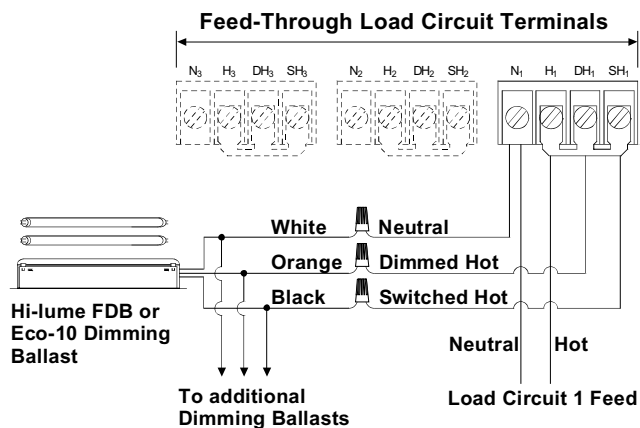

Diagram 3

Switched loads:

Incandescent, Magnetic Low-Voltage, Electronic Low-Voltage, Neon/Cold-Cathode, Non-Capacitive Fluorescent, and Metal Halide

Wiring notes:

1. Terminal blocks are rated for 2 #12 AWG max.
2. Load wiring may be 120VAC or 277VAC. Control circuit must be 120VAC.
3. The diagram represented a single load circuit model (HP-2). For two circuit (HP-4) or three circuit (HP-6) applications, repeat the same wiring method for each circuit. A different load type may be used on each circuit if desired. However, do not mix load types on the same load circuit.

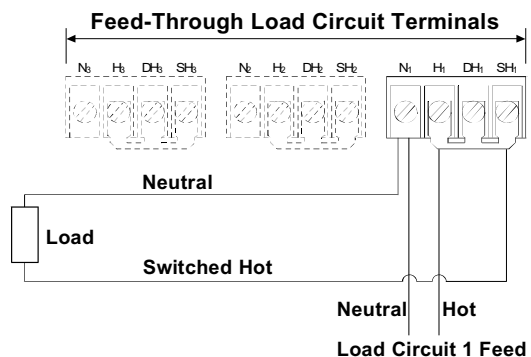

Control Wiring

Diagram 1: Single-pole Dimmer

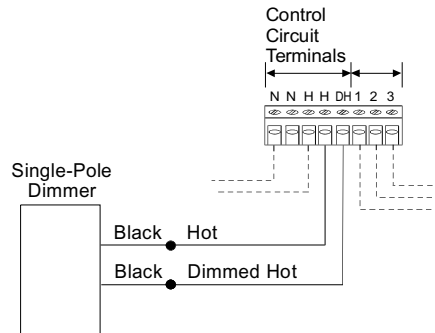

Diagram 2: Mechanical 3-way Dimmer (Single location)

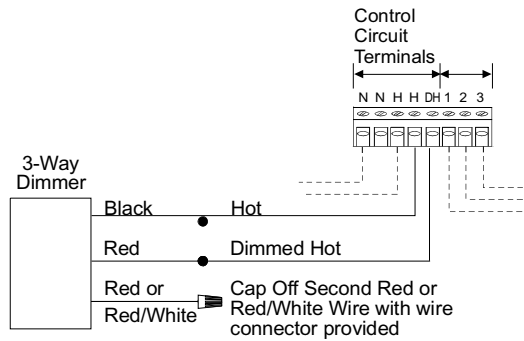

Diagram 3: Mechanical 3-way Dimmer (Two location)

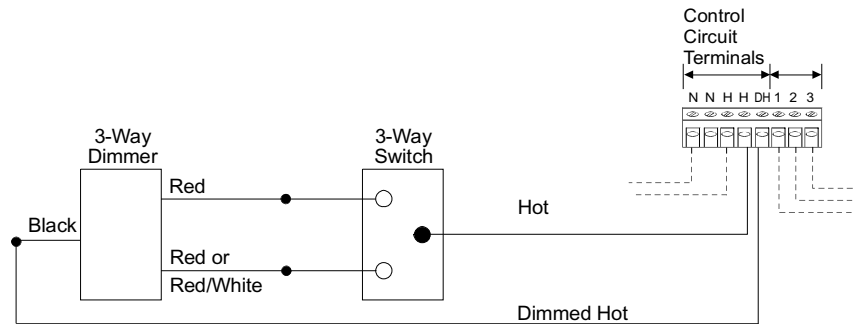
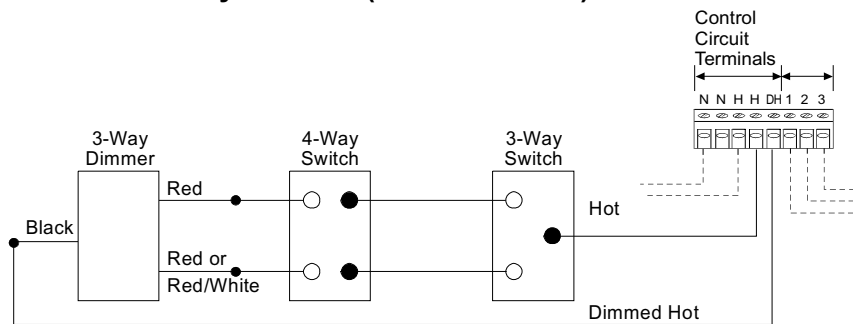

Diagram 4: Mechanical 3-way Dimmer (Three location)



Control Wiring

Diagram 5: Maestro Incandescent Dimmer (Single location)

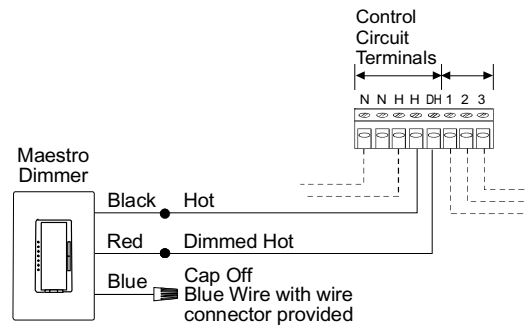

Diagram 6: Maestro Incandescent Dimmer (Two location)

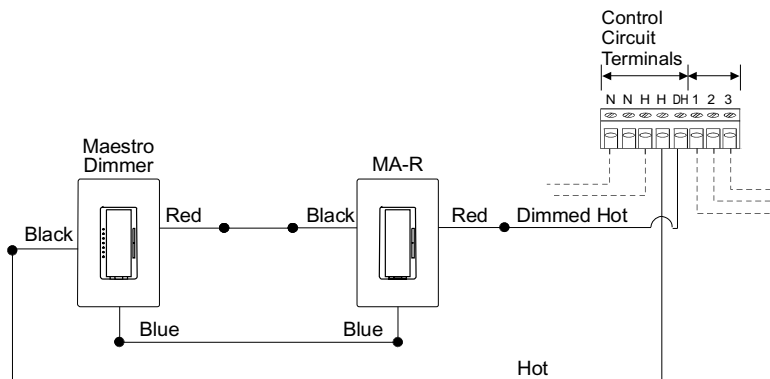
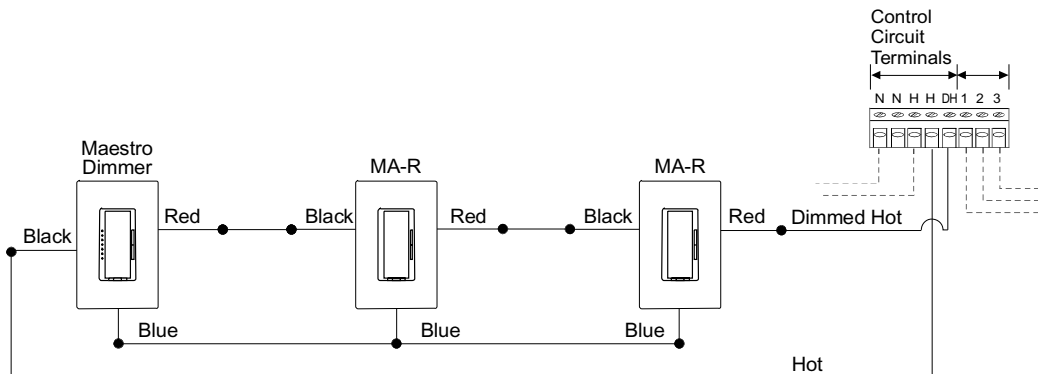

Diagram 7: Maestro Incandescent Dimmer (Three location)



Control Wiring

Diagram 8: Vareo Dimmer (Single location)

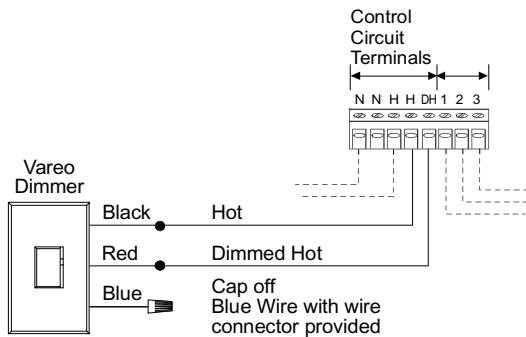

Diagram 9: Vareo Dimmer (Two location)

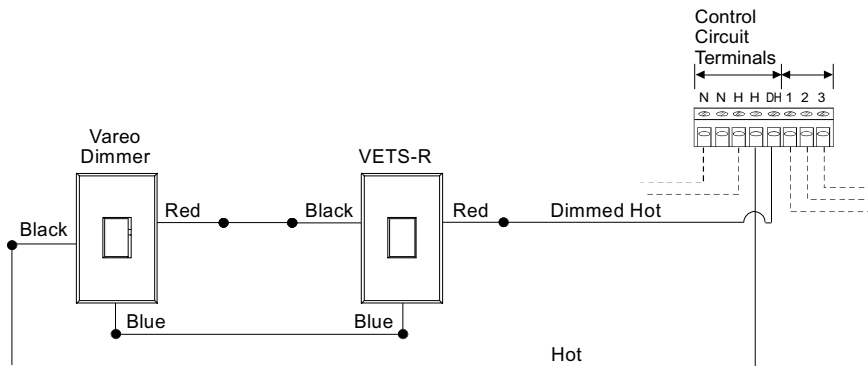
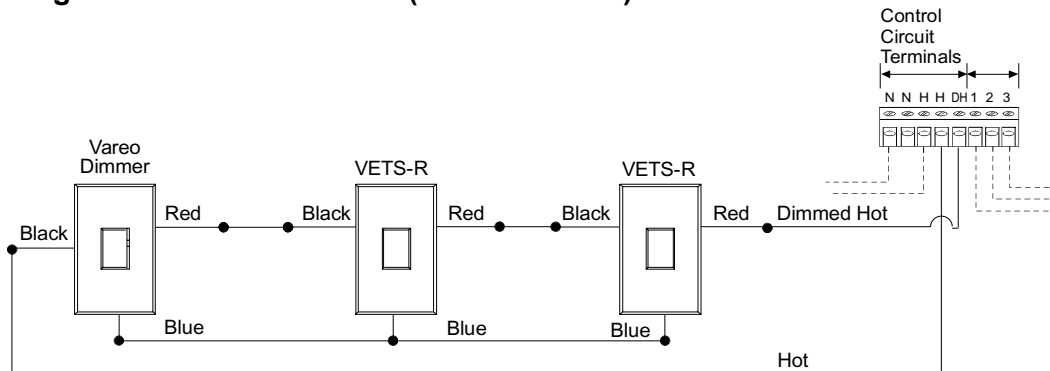

Diagram 10: Vareo Dimmer (Three location)



Control Wiring

Diagram 11: Nova T* Infrared Dimmer

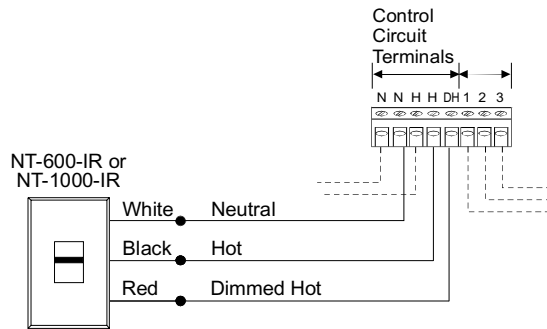

Diagram 12: Nova T* Omnislide Dimmers (Two location)

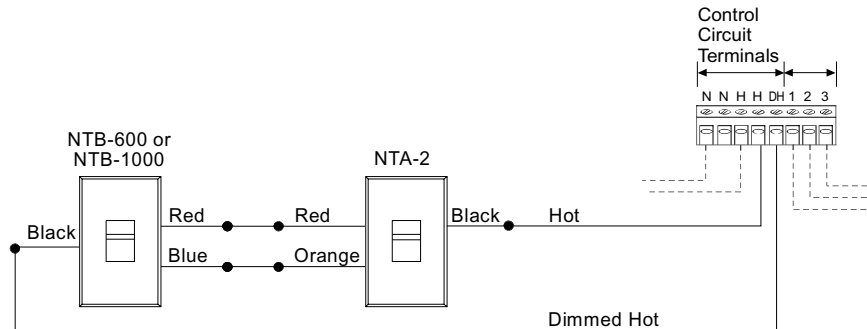
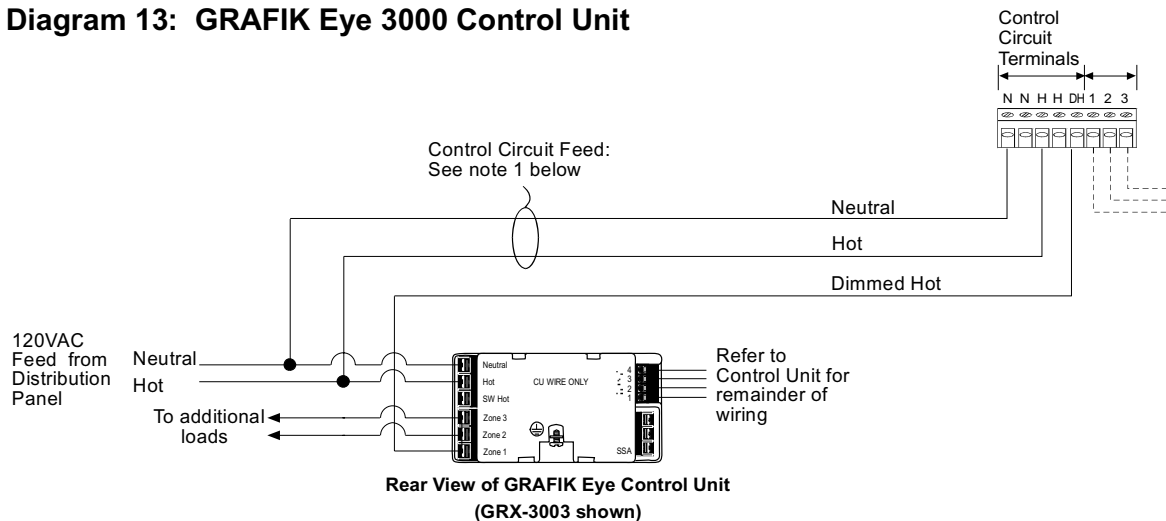

Diagram 13: GRAFIK Eye 3000 Control Unit



GRAFIK Eye 3000 Wiring Notes:

1. Control Circuit feed is shown coming from the GRAFIK Eye Control Unit's feed. The load for each Hi-POWER module connected to the circuit is 20VA. If the circuit does not have sufficient capacity to support the load of the module(s), the Control Circuit feed can be supplied from any circuit with sufficient capacity as long as it is on the **same phase** as the GRAFIK Eye Control Unit.
2. Load type should be set as incandescent on the GRAFIK Eye Control Unit.
3. Dimmed Hot is shown as Zone 1 in the diagram, but can be provided from any zone on the Control Unit.
4. Refer to GRAFIK Eye Installation Sheet for remainder of Control Unit wiring.

Control Wiring

Diagram 14: Class 2 Controls: NTRCS-1, NRCS-1, RCS-1

These controls provide single-location or multi-location raise/lower dimming with "off" at low-end. For other Class 2 control options refer to page 13.

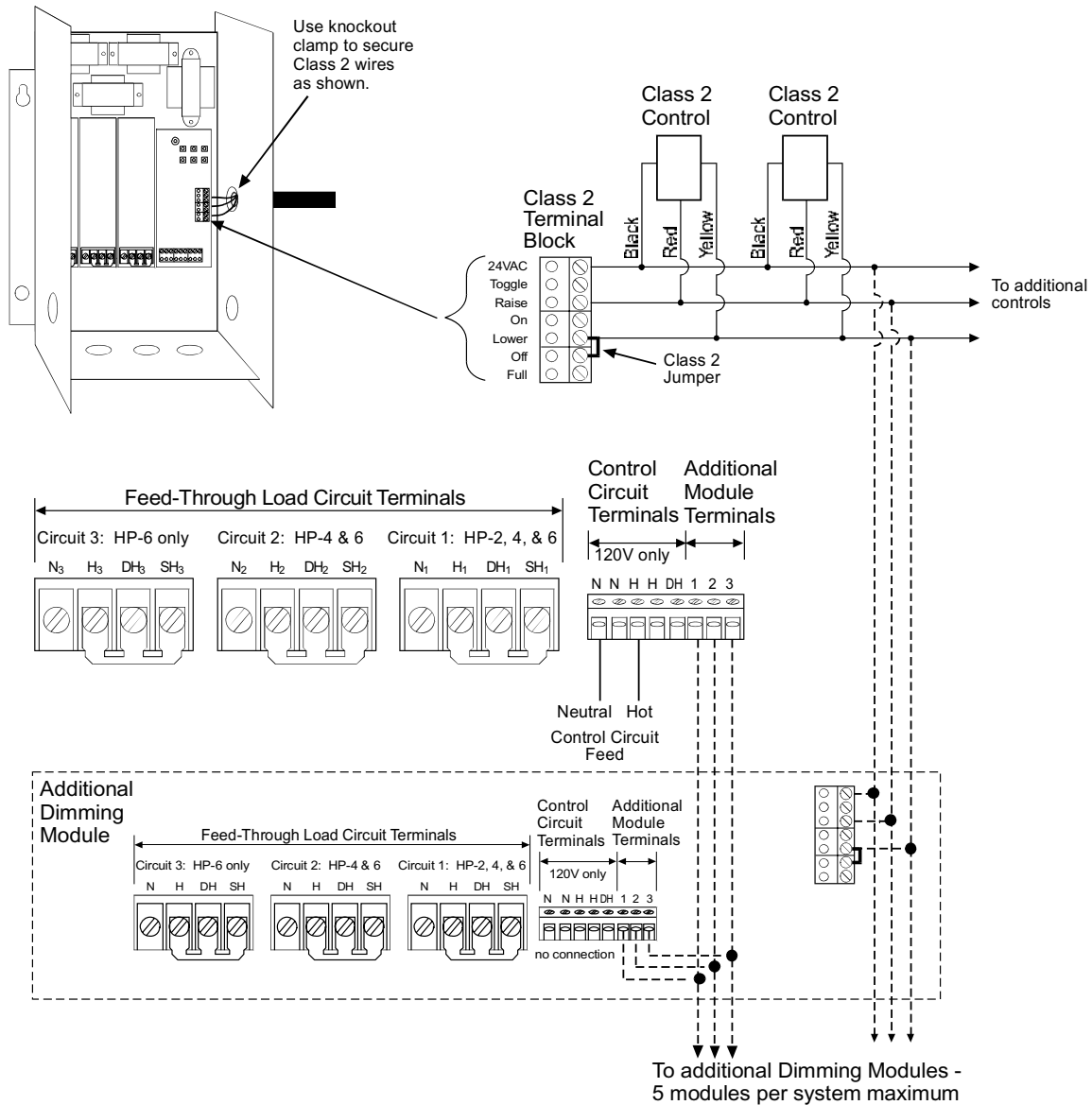

Class 2 Wiring Notes:

1. Class 2 terminal block is removable. It is packaged loose with the dimming module.
2. Position terminal block so wires exit as shown through the knockout indicated. Class 2 wiring must exit through this knockout.
3. To avoid contact between Class 2 wires and branch circuit wiring below, maintain 1-1/2" or less of Class 2 wiring within the enclosure. Do not leave any extra wire within the enclosure. Secure wiring using a knockout clamp.
4. **DO NOT** remove Class 2 factory bypass jumper between the Lower and Off terminals when using NTRCS-1, NRCS-1, or RCS-1 controls.

Class 2 Control Options

Definitions of Control Options

RAISE	Increases the light level while the switch is activated.
LOWER	Decreases light level while the switch is activated. Does not turn lights off.
LOWER/OFF	Decreases light level while the switch is activated. Turns lights off after the low-end is reached.
ON	Fades lights on to preset level.
OFF	Fades lights off.
TOGGLE	Fades lights on to preset level if they are off, fades lights off if they are on.
FULL ON	Turns lights on instantly to full when the switch is activated. No other control options are available while this switch is activated. Must be a maintained switch closure.
FADE RATE	Rate at which the light level changes while you activate a control option (for example, the rate at which the light level changes as you hold the RAISE button and the rate at which the lights fade on or off when you press the on or off). For all of the above options except "full on", the FADE RATE is adjustable inside the dimming module. See page 6 for location and adjustment instructions.

How to Access Control Options:

The desired Control Option is accessed with a 24VAC switch closure. Switch closures must be rated for switching 5mA at 24VAC RMS. See the chart below for the specific terminations of the switch closure on the Class 2 terminal block and type of switch closure permissible. See page 12 for the Class 2 terminal block location and terminal designations.

Typical Class 2 Control Wiring Examples:

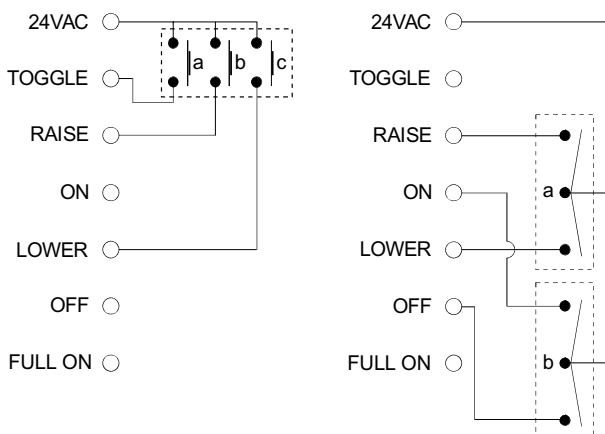

Example 1: Three SPST momentary pushbuttons. Switch "a" controls the TOGGLE on/off function. Switch "b" controls the RAISE function. Switch "c" controls the LOWER function.

Example 2: Two momentary, center off SPDT switches. Switch "a" performs the RAISE and LOWER functions. Switch "b" performs the ON/OFF functions.

Control Option	Switch Closure Between:	Switch Closure Type
RAISE	RAISE and 24VAC terminals	Either momentary or maintained
LOWER	LOWER and 24VAC terminals Remove factory installed jumper between LOWER & OFF terminals	Either momentary or maintained
LOWER/OFF	LOWER and 24VAC terminals DO NOT remove factory installed jumper between LOWER & OFF terminals	Either momentary or maintained
ON	24VAC and ON	Either momentary or maintained
OFF	24VAC and OFF	Either momentary or maintained
TOGGLE	24VAC and TOGGLE	Must be momentary
FULL ON	24VAC and FULL ON	Must be maintained

Neon/Cold-Cathode Dimming

Overview

Successful dimming of neon and cold-cathode sources can be achieved through proper equipment selection and installation. The following installation suggestions and Derated Luminous Tube Length Chart for Dimming Applications must be used for optimum performance.

1. If equipment is selected and installed as specified here, a dimming range of 95-10% light should be possible.
2. The electrical properties of argon fill gas make it easier to dim than red neon fill gas; therefore, installations using argon fill gas will be more successful than neon installations.
3. In addition to the following guidelines, all installations must meet the NEC and local codes.

Lamps

1. Neon/cold-cathode lamps must be manufactured to proper lamp pressurization (standard lamp pressure) without impurities. If pressurization is not standard or impurities are present, poor performance will result.
2. Neon/cold-cathode tubing should be well supported to avoid rattling when dimmed.
3. Lutron recommends using only the transformer/tube combinations in the Derated Luminous Tube Length Chart for Dimming Applications. Other combinations will flicker and perform poorly. Note that there are few successful combinations for red neon tubes smaller than 11 mm.

Transformers

1. Normal power factor transformers must be used; electronic transformers cannot be dimmed.
2. When choosing transformer secondary currents, note that the higher the transformer current rating, the brighter the light from the tube.
3. Transformers must be sized according to the chart. These modified charts must be used by neon/cold-cathode transformer suppliers to size the transformer for dimming applications. Do not use standard luminous tube length charts to size transformers in dimming applications. Poor performance will result.
4. Transformers must be thermally-protected or fused.
5. Power factor correction capacitors, if present must be disconnected. If power correction is required, call the toll-free **Lutron Hotline** for details on power factor correction at the lighting controller.
6. Transformers should be sized to run as close as possible to full load footage as shown in the chart.

Wiring

1. High voltage (GTO-15) cable connecting a transformer output terminal to a cold-cathode tube must not be longer than twenty feet.
2. All GTO-15 cables should be spaced a minimum of four inches from any other GTO-15 cable.
3. It is recommended that only one GTO-15 cable be run per conduit.
4. Optimal dimming performance is achieved when GTO-15 cable is enclosed in plastic conduit or run without conduit. If codes require metal conduit, aluminum is preferred and lengths must be kept to less than six feet per transformer.
5. Braided or shielded GTO-15 cable must not be used for dimming applications.

Luminous Tube Length Chart for Neon/Cold-cathode Dimming Applications

Transformer Ratings			Approximate number of feet of tubing																					
Secondary Voltage (V)	Secondary Short Circuit Current (mA)	Input Volt-Amperes with Secondary Short Circuit (VA)	Neon Fill (clear or fluorescent red)									Argon /Mercury Fill (colors other than neon red)												
			Tube Size (millimeters)									Tube Size (millimeters)												
			25	22	20	18	15	14	13	12	11	10	9	25	22	20	18	15	14	13	12	11	10	9
15000	60	900	77	64	58	54	45	X	X	X	X	X	X	96	80	72	64	58	51	48	44	38	35	X
	30	450	77	64	58	54	45	X	X	X	X	X	X	96	80	72	64	58	51	48	44	38	35	X
12000	20	270					X	X	X	X	X	X	X					X	X	X	X	X	X	X
	60	720	59	50	46	41	34	32	29	26	X	X	X	76	63	56	50	44	40	37	35	30	28	X
	30	360	59	50	46	41	34	32	29	26	X	X	X	76	63	56	50	44	40	37	35	30	28	X
9000	20	225					X	X	X	X	X	X	X					X	X	X	X	X	X	X
	120	1080	58	49	41	35	28	25	25	23	20	17	X	74	62	50	42	37	33	30	28	26	22	X
	60	540	50	43	36	30	25	23	22	20	18	16	X	64	54	44	36	32	29	26	26	22	20	X
7500	30	270	50	43	36	30	25	23	22	20	X	X	X	64	54	44	36	32	29	26	26	22	20	X
	20	180					21	20	18	16	X	X	X					27	25	23	22	18	16	X
	120	900	44	35	29	24	22	20	20	17	16	14	X	56	44	36	31	28	26	25	22	20	18	X
6000	60	450	38	31	25	21	20	18	16	16	14	13	X	49	38	31	28	25	22	22	20	18	16	X
	30	225	38	31	25	21	20	18	16	16	X	X	X	49	38	31	28	25	22	22	20	18	16	X
	20	150					16	16	15	14	X	X	X					22	20	18	17	15	14	X
5000	120	720	35	29	24	20	18	16	16	14	13	11	X	44	37	30	26	22	21	20	18	16	14	X
	60	360	30	25	21	17	16	14	14	12	11	10	X	38	32	26	22	19	18	17	15	14	13	X
	30	180	30	25	21	17	16	14	14	12	X	X	X	38	32	26	22	19	18	17	15	14	13	X
4000	20	130					14	13	12	10	X	X	X					18	16	14	14	12	10	X
	120	600	28	24	20	16	15	14	13	10	9	8	X	37	30	25	21	18	18	15	14	12	10	X
	60	300	25	21	17	14	13	12	11	9	8	8	X	32	26	22	18	16	15	13	13	10	10	X
3000	30	160	25	21	17	14	13	12	11	9	X	X	X	32	26	22	18	16	15	13	13	10	10	X
	20	100					11	10	10	8	X	X	X					14	13	12	11	9	8	X
	60	240	20	17	14	12	10	9	8	8	7	6	X	26	22	18	15	14	13	12	11	9	8	X
2000	30	140	20	17	14	12	10	9	8	8	X	X	X	26	22	18	15	14	13	12	11	9	8	X
	20	90					8	8	8	7	X	X	X					11	10	10	10	7	6	X
	60	180	13	10	9	8	8	7	7	6	5	5	X	18	14	13	11	10	9	8	7	6	6	X
2000	30	100	13	10	9	8	8	7	7	6	5	5	X	18	14	13	11	10	9	8	7	6	6	X
	20	75					6	6	5	5	4	3	X					8	7	6	6	5	4	X
	30	75					5	5	5	5	X	X	X					7	6	6	6	5	4	X
	20	50					5	4	4	4	X	X	X					6	6	6	5	4	3	X
Recommended gas pressure, mm/Hg			6	7	7.5	8	9	10	10	11	12	13	6	7	7.5	8	9	10	10	11	12	13		

NOTES:

- This table has been modified for dimming applications. When calculating total length of tube, add approximately 1 foot for each section of tubing (each pair of electrodes).
- **Do not** use this table for non-dimming installations.
- X denotes a combination which cannot be successfully dimmed.
- Tube length is shown in feet. To convert to meters: 1 foot = 0.305 meters.

WARNING: Potentially hazardous high voltage can be present. Testing, handling, and servicing should be performed only by a qualified electrician.

Troubleshooting Guide

Symptom	Causes	Solution
Lights do not come on.	Load input feed power not present	Check load power indicator light(s) and verify that all input breakers are on and wiring is connected properly.
	Control input feed power is not present.	Check control power indicator light and verify that the control wiring is connected properly.
Lights cannot be dimmed.	Bypass jumpers are not removed.	Remove bypass jumpers on load circuit terminal blocks.
	Dimmed load is miswired to switched hot output load terminal.	Compare load wiring to wiring diagrams on page 7.
	Low-end trim is set too high.	Refer to page 6 and adjust low-end trim.
	Control dimmer is not operating properly.	Check that Control Power Indicator Light dims when control is adjusted; check wiring.
	Shorted triac - usually caused by a load short or overload.	Try to adjust high-end or low-end trim. If lights remain at full, triac is shorted. Contact Lutron for a Replacement Triac Kit . Verify proper load size and load wiring before replacing triac.
Portion of slider travel does not affect light level.	High- and/or low-end trim need adjustment.	Refer to page 6 and adjust high- and/or low-end trim settings.
Hi-lume FDB or Eco-10 lamps flicker at low-end.	Lamps not operated at full intensity before dimming.	Operate lamps at full intensity for 100 hours prior to dimming.
	Hi-lume FDB or ECO 10 ballasts improperly wired to Dimming Module.	Refer to wiring diagram on page 7 and correct wiring.
Neon lamps flicker at low-end.	Low-end trim is set too low.	Refer to page 6 and adjust low-end trim.
	There is a problem with the neon installation.	Refer to pages 14 and 15 for approved neon dimming installation specifications.
Switched load does not turn off.	Bypass jumper not removed.	Remove bypass jumpers on load circuit terminal blocks.
Lights do not dim low enough.	Low-end trim needs adjustment.	Refer to page 6 and adjust low-end trim.
Lights do not brighten to full or remain at low-end.	High-end trim is set too low.	Refer to page 6 and adjust high-end trim.
Lights on different dimming modules dim at different rates when using Class 2 raise/ lower controls.	Fade rate adjustment set differently on each module.	Refer to page 6 and adjust fade rates so that they are the same.
Circuit breaker trips on power up.	Additional dimming module slaves wired incorrectly.	Compare additional module wiring to diagrams on page 4.

Worldwide Technical and Sales Assistance

If you need assistance, call the toll-free **Lutron Technical Assistance Hotline:**
 (800) 523-9466 (U.S.A., Canada and the Caribbean)
 Other countries call (610) 282-3800
 FAX (610) 282-3090

Warranty

Lutron will, at its option, repair or replace any control that is defective in materials or manufacture within one year after the purchase. For warranty service, return control to place of purchase or mail to Lutron at 7200 Suter Road, Coopersburg, PA 18036-1299, postage prepaid.

This warranty is in lieu of all other warranties, express or implied, and the implied warranty of merchantability is limited to one year from purchase. This warranty does not cover the cost of installation, removal, or reinstallation, or damage resulting from misuse, abuse, or improper wiring or installation.

This warranty gives you specific legal rights, and you may also have other rights which vary from state to state. Some states do not allow the exclusion or limitation of incidental or consequential damages or limitations on how long an implied warranty may last, so the above limitations and exclusions may not apply to you.

LUTRON®

Lutron Electronics Co., Inc.
 7200 Suter Road
 Coopersburg, PA 18036-1299 USA
 Made and Printed in U.S.A. 6/96 P/N 030-452 Rev. B

LUT-LBX Synthetic Minimum Load

For use with Reverse and Forward Phase Dimmers

Installation Instructions

Please Read

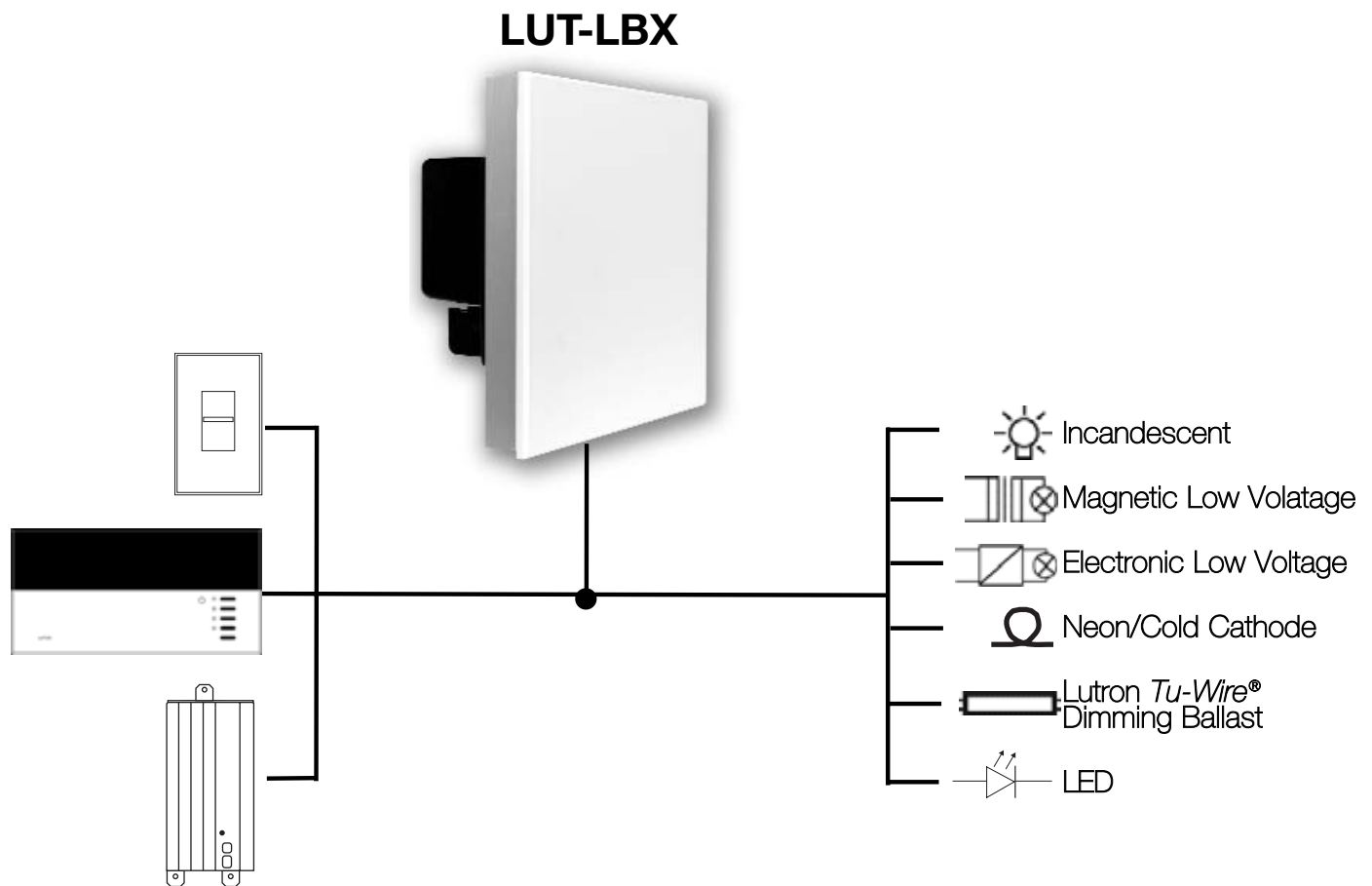

- This device provides capability for certain Lutron dimmers to control low-wattage loads from 0 watts up to the dimmer's minimum rating.
- It presents a simulated load to the dimmer to meet the minimum load requirements even when the actual load is smaller.

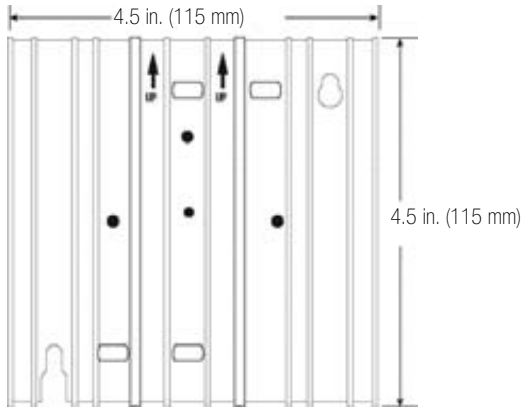

Interface shown with faceplate removed

This “load-side” equipment installs on the zone wiring in parallel with the lighting load. It provides an equivalent minimum load for Lutron dimmers when the actual load is too low for proper control unit operation.

Input:

- 120 V \sim 100 mA 50/60 Hz (LUT-LBX)
- Power dissipation less than 10 watts

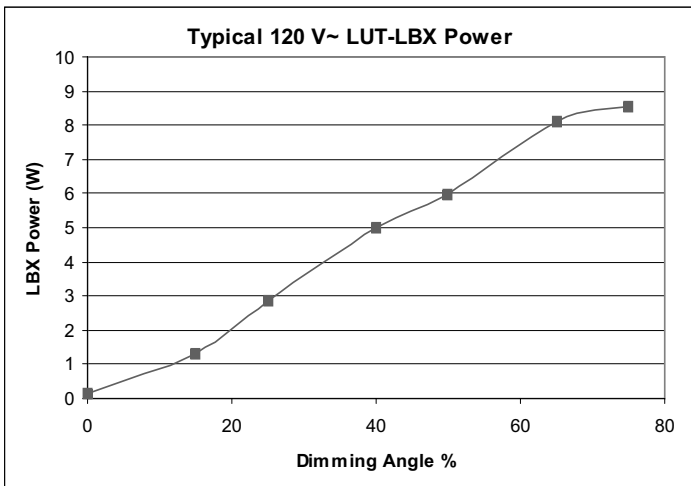

Danger! Always turn OFF the circuit breakers/MCB or remove the main fuses from the power line before doing any work. Failure to do so can result in serious personal injury. **Disconnect all power sources before servicing unit.**

1. This Interface must be installed by a qualified electrician in accordance with all applicable regulations.
2. Improper wiring can result in personal injury, damage to the Interface, or damage to other equipment.
3. One LUT-LBX per circuit below minimum load.
4. The LUT-LBX must be mounted with arrows on yoke facing upward to ensure adequate cooling.
5. **CAUTION!** Dimmed magnetic low-voltage transformers: To avoid excessively high current flow that can cause transformer overheating and failure, observe the following:
 - (a) Do not operate the MLV dimmers with all of the lamps removed or with any lamps inoperative.
 - (b) Replace any burned out lamps immediately.
 - (c) Use only transformers that incorporate thermal protection or fused primary windings.
6. The LUT-LBX does not change the approved load types of the dimmer. Use the required dimmer for the given load type.
7. For LED lighting dimming operation, refer to Application Note #138.

Test load for short circuits

- Turn power Off.
- Connect standard switch between Hot/Live lead and the load wire to test circuit.
- Turn power On and check for short or open circuits.

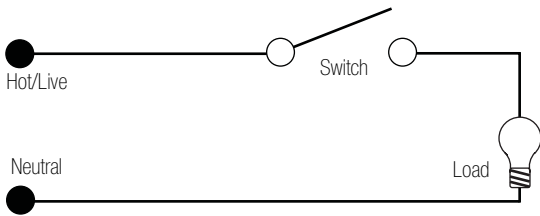

Installation Instructions

1. Turn power Off to the Control Unit.
2. Mount standard U.S. 2-gang wallbox (available from Lutron, P/N 241-496); 3 1/2 in. (89 mm) deep is strongly recommended, 2 3/4 in. (68 mm) minimum. Allow at least 4 1/2 in. (110 mm) clearance above/below Interfaces to ensure proper heat dissipation.
3. Strip 1/2 in. (12 mm) insulation from all wires in wallbox and wire as shown. All connections are made using #12 AWG to #16 AWG (2.5 - 1 mm²) wire. Power terminals can accept up to two #12 AWG (2.5 mm²) wires. The recommended installation torque is 9.0 in.●lbs. (1.0 N●m) for line voltage connections.



Single-Zone Wiring

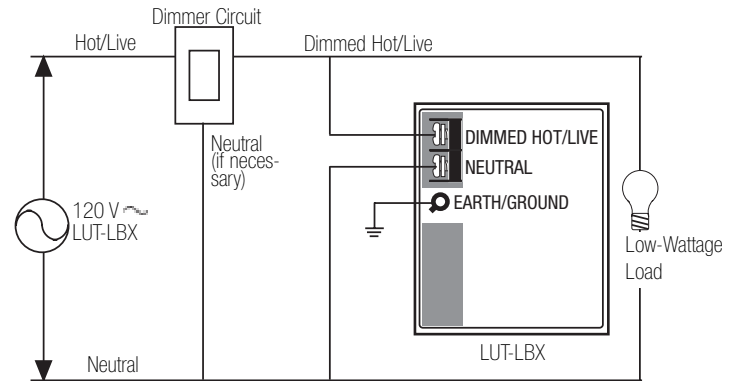

Dual-Zone Wiring

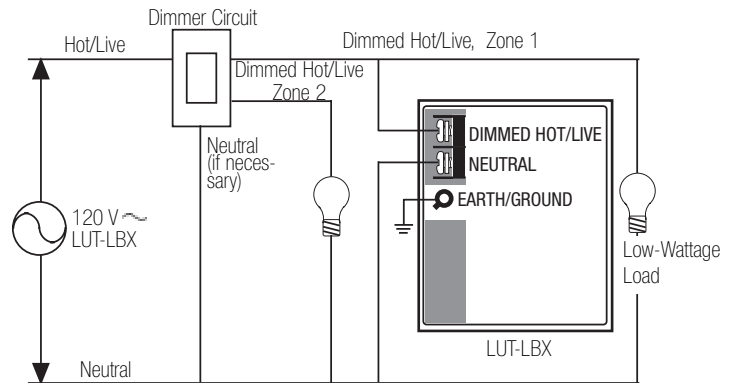

* Wallbox may be recess mounted or surface mounted. If mounting Interface in a panel, please refer to Panel Mounting section for important information.

Mounting: Interface must be mounted *vertically!*

1. Confirm all connections and mount the Interface using the screws provided.
2. Restore power to the system.

Recess Mount

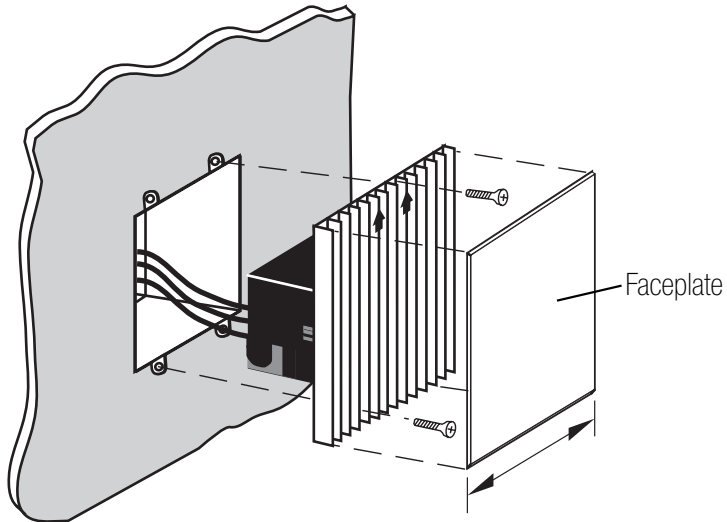

Surface Mount

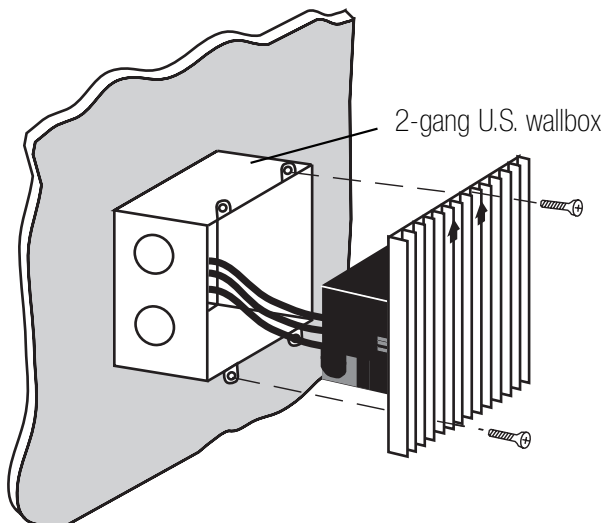

Panel Mounting

- The enclosure must be in accordance with all local and national electrical codes.
- Lutron does not recommend using a door to enclose the front of a panel, since this restricts airflow to the *GRAFIK Eye* Control Units and Interfaces.
- If mounting multiple Control Units or Interfaces in an enclosure:
 1. Ambient temperature within an enclosure must remain between 32 - 104 °F (0 - 40 °C).
 2. If not mounting in a metal enclosure, all units **must** be mounted in a wallbox.
- To improve heat dissipation of the Interface, remove the faceplate from the unit.



GRAFIK Eye Control Units and Interface Units dissipate heat when operating. Obstructing these units can cause malfunction to both the Control Unit and the Interface if ambient temperature does not remain between 32 - 104 °F (0 - 40 °C).

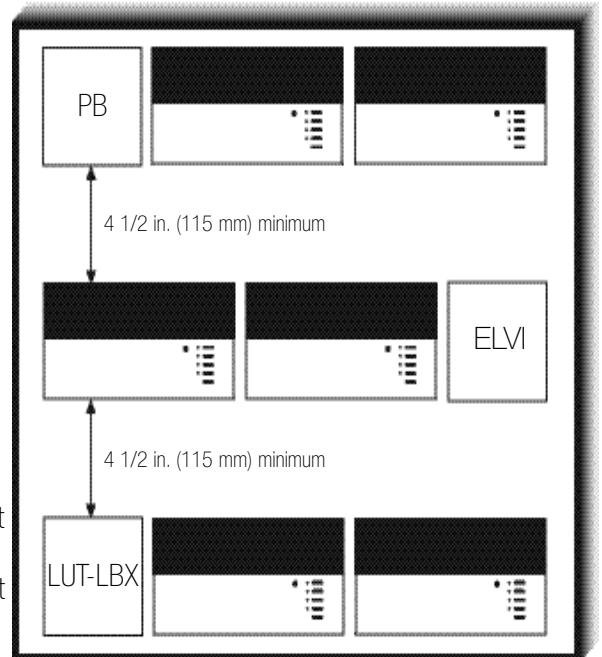

Troubleshooting Guide

Symptom	Causes	Solution
Lights do not come on.	Power is off	Restore power to the control unit.
	Miswire	Confirm wiring per wiring diagrams.
	Bulb(s)/lamp(s) burned out	Replace bulb(s)/lamp(s).
	Control Unit	Refer to troubleshooting section of Control Unit Installation Guide.
Lights turn on/off unexpectedly.	Load Type	Confirm that the load type being switched/dimmed is compatible with the control unit or dimmer being used. Line/Mains voltage phase control dimming only.
	Miswire	Confirm wiring per wiring diagrams.
	Control Unit	Refer to the troubleshooting section of Control Unit Installation Guide.
	Damaged/disconnected LUT-LBX	Lighting load does not meet minimum requirements of dimmer; check for damage or disconnection.

Internet: www.lutron.com
E-mail: product@lutron.com

WORLD HEADQUARTERS

Lutron Electronics Co., Inc.
7200 Suter Road, Coopersburg, PA
18036
TEL +1-610-282-3800
FAX +1-610-282-1243
Toll-Free 1-888-LUTRON1
Technical Support 1-800-523-9466

EUROPEAN HEADQUARTERS

Lutron EA Ltd.
6 Sovereign Close, Wapping, London,
E1W 3JF United Kingdom
TEL +44-207-702-0657
FAX +44-207-480-6899
FREEPHONE (UK) 0800-282-107
Technical support +44-(0)20-7680-4481

ASIAN HEADQUARTERS

Lutron GL Ltd.
15 Hoe Chiang Road,
#07-03 Euro Asia Centre,
Singapore 089316
TEL +65-6220-4666
FAX +65-6220-4333

Hong Kong

Lutron GL Ltd.
Room 2808, 28/F,
248 Queen's Road East,
Wanchai, Hong Kong
TEL +852-2104-7733
FAX +852-2104-7633

Japan

Lutron Asuka Co. Ltd.
No. 16 Kowa Building, 4F, 1-9-20,
Akasaka, Minato-ku, Tokyo 107-0052
Japan
TEL +81-3-5575-8411
FAX +81-3-5575-8420

Asia Technical Hotlines

Northern China: 10-800-712-1536
Southern China: 10-800-120-1536
Hong Kong: 800-901-849
Indonesia: 001.803.011.3994
Japan: +81.3.5575.8411
Macau: 0800.401
Singapore: 800-120-4491
Taiwan: 00-801-137-737
Thailand: 001-800-120-665853
Other Areas: +65-6220-4666

Lutron Electronics Co., Inc. One Year Limited Warranty

For a period of one year from the date of purchase, and subject to the exclusions and restrictions described below, Lutron warrants each new unit to be free from manufacturing defects. Lutron will, at its option, either repair the defective unit or issue a credit equal to the purchase price of the defective unit to the Customer against the purchase price of comparable replacement part purchased from Lutron. Replacements for the unit provided by Lutron or, at its sole discretion, an approved vendor may be new, used, repaired, reconditioned, and/or made by a different manufacturer.

If the unit is commissioned by Lutron or a Lutron approved third party as part of a Lutron commissioned lighting control system, the term of this warranty will be extended, and any credits against the cost of replacement parts will be prorated, in accordance with the warranty issued with the commissioned system, except that the term of the unit's warranty term will be measured from the date of its commissioning.

EXCLUSIONS AND RESTRICTIONS

This Warranty does not cover, and Lutron and its suppliers are not responsible for:

1. Damage, malfunction or inoperability diagnosed by Lutron or a Lutron approved third party as caused by normal wear and tear, abuse, misuse, incorrect installation, neglect, accident, interference or environmental factors, such as (a) use of incorrect line voltages, fuses or circuit breakers; (b) failure to install, maintain and operate the unit pursuant to the operating instructions provided by Lutron and the applicable provisions of the National Electrical Code and of the Safety Standards of Underwriter's Laboratories; (c) use of incompatible devices or accessories; (d) improper or insufficient ventilation; (e) unauthorized repairs or adjustments; (f) vandalism; or (g) an act of God, such as fire, lightning, flooding, tornado, earthquake, hurricane or other problems beyond Lutron's control.
 2. On-site labor costs to diagnose issues with, and to remove, repair, replace, adjust, reinstall and/or reprogram the unit or any of its components.
 3. Equipment and parts external to the unit, including those sold or supplied by Lutron (which may be covered by a separate warranty).
 4. The cost of repairing or replacing other property that is damaged when the unit does not work properly, even if the damage was caused by the unit.
- EXCEPT AS EXPRESSLY PROVIDED IN THIS WARRANTY, THERE ARE NO EXPRESS OR IMPLIED WARRANTIES OF ANY TYPE, INCLUDING ANY IMPLIED WARRANTIES OF FITNESS FOR A PARTICULAR PURPOSE OR MERCHANTABILITY. LUTRON DOES NOT WARRANT THAT THE UNIT WILL OPERATE WITHOUT INTERRUPTION OR BE ERROR FREE.

NO LUTRON AGENT, EMPLOYEE OR REPRESENTATIVE HAS ANY AUTHORITY TO BIND LUTRON TO ANY AFFIRMATION, REPRESENTATION OR WARRANTY CONCERNING THE UNIT. UNLESS AN AFFIRMATION, REPRESENTATION OR WARRANTY MADE BY AN AGENT, EMPLOYEE OR REPRESENTATIVE IS SPECIFICALLY INCLUDED HEREIN, OR IN STANDARD PRINTED MATERIALS PROVIDED BY LUTRON, IT DOES NOT FORM A PART OF THE BASIS OF ANY BARGAIN BETWEEN LUTRON AND CUSTOMER AND WILL NOT IN ANY WAY BE ENFORCEABLE BY CUSTOMER.

IN NO EVENT WILL LUTRON OR ANY OTHER PARTY BE LIABLE FOR EXEMPLARY, CONSEQUENTIAL, INCIDENTAL OR SPECIAL DAMAGES (INCLUDING, BUT NOT LIMITED TO, DAMAGES FOR LOSS OF PROFITS, CONFIDENTIAL OR OTHER INFORMATION, OR PRIVACY; BUSINESS INTERRUPTION; PERSONAL INJURY; FAILURE TO MEET ANY DUTY, INCLUDING OF GOOD FAITH OR OF REASONABLE CARE; NEGLIGENCE, OR ANY OTHER PECUNIARY OR OTHER LOSS WHATSOEVER), NOR FOR ANY REPAIR WORK UNDERTAKEN WITHOUT LUTRON'S WRITTEN CONSENT ARISING OUT OF OR IN ANY WAY RELATED TO THE INSTALLATION, DEINSTALLATION, USE OF OR INABILITY TO USE THE UNIT OR OTHERWISE UNDER OR IN CONNECTION WITH ANY PROVISION OF THIS WARRANTY, OR ANY AGREEMENT INCORPORATING THIS WARRANTY, EVEN IN THE EVENT OF THE FAULT, TORT (INCLUDING NEGLIGENCE), STRICT LIABILITY, BREACH OF CONTRACT OR BREACH OF WARRANTY OF LUTRON OR ANY SUPPLIER, AND EVEN IF LUTRON OR ANY OTHER PARTY WAS ADVISED OF THE POSSIBILITY OF SUCH DAMAGES.

NOTWITHSTANDING ANY DAMAGES THAT CUSTOMER MIGHT INCUR FOR ANY REASON WHATSOEVER (INCLUDING, WITHOUT LIMITATION, ALL DIRECT DAMAGES AND ALL DAMAGES LISTED ABOVE), THE ENTIRE LIABILITY OF LUTRON AND OF ALL OTHER PARTIES UNDER THIS WARRANTY ON ANY CLAIM FOR DAMAGES ARISING OUT OF OR IN CONNECTION WITH THE MANUFACTURE, SALE, INSTALLATION, DELIVERY, USE, REPAIR, OR REPLACEMENT OF THE UNIT, OR ANY AGREEMENT INCORPORATING THIS WARRANTY, AND CUSTOMER'S SOLE REMEDY FOR THE FOREGOING, WILL BE LIMITED TO THE AMOUNT PAID TO LUTRON BY CUSTOMER FOR THE UNIT. THE FOREGOING LIMITATIONS, EXCLUSIONS AND DISCLAIMERS WILL APPLY TO THE MAXIMUM EXTENT ALLOWED BY APPLICABLE LAW, EVEN IF ANY REMEDY FAILS ITS ESSENTIAL PURPOSE.

TO MAKE A WARRANTY CLAIM

To make a warranty claim, promptly notify Lutron within the warranty period described above by calling the Lutron Technical Support Center at (800) 523-9466. Lutron, in its sole discretion, will determine what action, if any, is required under this warranty. To better enable Lutron to address a warranty claim, have the unit's serial and model numbers available when making the call. If Lutron, in its sole discretion, determines that an on-site visit or other remedial action is necessary, Lutron may send a Lutron Services Co. representative or coordinate the dispatch of a representative from a Lutron approved vendor to Customer's site, and/or coordinate a warranty service call between Customer and a Lutron approved vendor.

This warranty gives you specific legal rights, and you may also have other rights which vary from state to state. Some states do not allow limitations on how long an implied warranty lasts, so the above limitation may not apply to you. Some states do not allow the exclusion or limitation of incidental or consequential damages, so the above limitation or exclusion may not apply to you.

These products may be covered under one or more of the following U.S. patents: 4,797,599; 4,803,380; and corresponding foreign patents. Lutron, the sunburst logo, Tu-Wire, and Grafik Eye are registered trademarks of Lutron Electronics Co., Inc. © 2006 Lutron Electronics Co., Inc.



Lutron Electronics Co., Inc.
Made and printed in U.S.A.
P/N 030-852 Rev. A 01/07



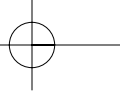

GRAFIK Eye® Power Interfaces

Power Booster (PB) Electronic Low Voltage Interface (ELVI) Fluorescent Dimming Ballast Interface (FDBI)

Installation Instructions — Please Read

PB

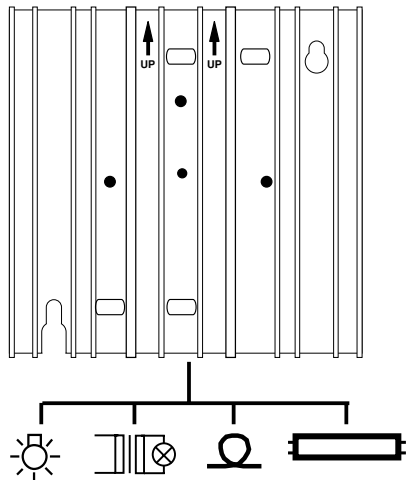

Incandescent
Magnetic Low Voltage
Neon/Cold Cathode
Lutron *Tu-Wire*® Dimming Ballast

ELVI

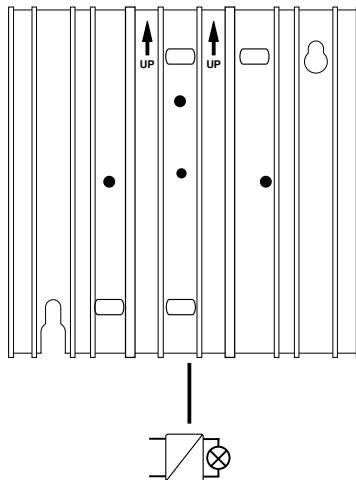

Electronic Low Voltage

FDBI

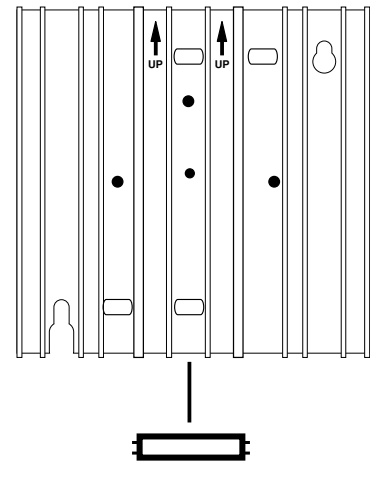

Lutron *Hi-lume*® or *Eco-10*™
Fluorescent Dimming Ballast

LUTRON®

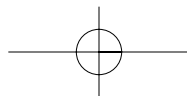

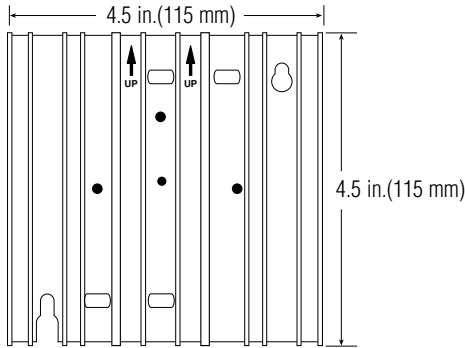

Interface shown with faceplate removed

This “load-side” equipment installs on the zone wiring between the Control Unit* and the lighting load.

The **PB** increases a Control Unit’s zone load capacity for Incandescent/Halogen (Tungsten), Magnetic Low Voltage, Neon/Cold Cathode, and Lutron *Tu-Wire* load types.

The **ELVI** enables a zone of the Control Unit to control Electronic Low-Voltage loads.

The **FDBI** enables a zone of the Control Unit to control fluorescent loads with Lutron *Hi-lume* or *Eco-10* phase-controlled dimming ballasts.

The maximum load capacity for each Interface is shown in the table that follows.

Unit	120V	220-240V (AU)	230V (CE)
PB	1920W/VA 16A	2400W/VA 10A	1840W/VA† 8A†
ELVI	1000W/VA 8.3A	1200W/VA 5A	1200W/VA 5.2A
FDBI	1920W/VA 16A	2400W/VA 10A	— —

† 1200W/VA and 5.2A for flush mount (as shown on pg. 6).



Danger! Always turn OFF the circuit breakers/MCB or remove the main fuses from the power line before doing any work. Failure to do so can result in serious personal injury. More than one MCB can power this device.

Disconnect all power sources before servicing unit.

1. This Interface must be installed by a qualified electrician in accordance with all applicable regulations.
2. Improper wiring can result in personal injury, damage to the Interface, or damage to other equipment.
3. Up to two **PB/ELVI/FDBIs** per zone.
4. The **PB/ELVI/FDBI** must be mounted with arrows facing upward to ensure adequate cooling.
5. **PB:** If using low-voltage incandescent fixtures, use only with iron core (magnetic) transformers.
6. **ELVI:** Use only with solid-state (electronic) low-voltage transformers that are manufacturer approved to be dimmed by reverse phase control.
7. **CAUTION!** Dimmed magnetic low-voltage transformers: To avoid excessively high current flow that can cause transformer overheating and failure, observe the following:
 - (a) Do not operate the Interface with all of the lamps removed or with any lamps inoperative.
 - (b) Replace any burned out lamps immediately.
 - (c) Use only transformers that incorporate thermal protection or fused primary windings.
8. **ELVI/FDBI:** These Interfaces contain a thermal device that turns Off the Interface if overloaded. The Interface will turn On when it cools.

* See Page 5 for other Lutron products that can be used to control your PB/ELVI/FDBI.

Test load for short circuits

- Turn power Off.
- **PB/ELVI:** Connect standard switch between Hot/Live lead and the load wire to test circuit.
- **FDBI:** Connect standard switch between Hot/Live lead and the Dimmed Hot/Live and switched Hot/Live leads of the ballast.
- Turn power On and check for short or open circuits.

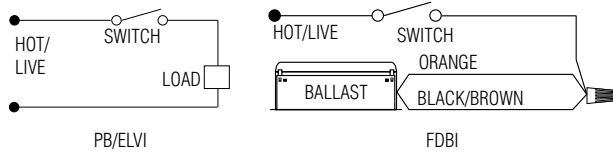

Single-Feed Wiring for PB/ELVI 120V and 220-240V



The **PB/ELVI** may be on the same circuit as the Control Unit *only if* the total load does not exceed the rating of the breaker.

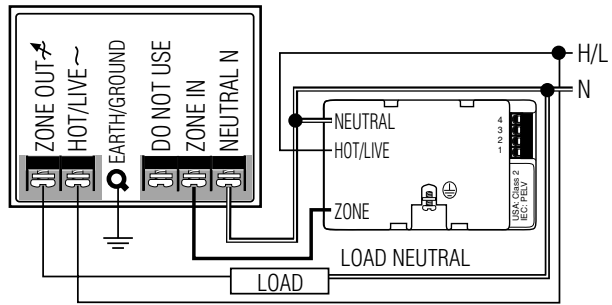

Wiring Instructions

1. Turn power Off to the Control Unit *and* the feed to the **PB, ELVI, or FDBI!**
2. Mount standard U.S. 2-gang wallbox* (available from Lutron, P/N 241-641), 3 1/2 in. (87 mm) deep is strongly recommended, 2 3/4 in. (68 mm) minimum. Allow at least 4 1/2 in. (110 mm) clearance above/below Interfaces to ensure proper heat dissipation.
3. Strip 1/2 in. (12 mm) insulation from all wires in wallbox and wire as shown. All connections are made using #12 AWG (2.5 mm²) wire. Power terminals can accept up to two #12 AWG (2.5 mm²) wires. The NEUTRAL N terminal is for the Control neutral, **not** the load neutral! The recommended installation torque is 9.0 in.•lbs. (1.0 N•m) for line voltage connections.

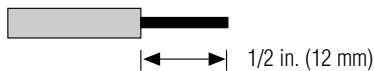

3

Dual-Feed Wiring for PB/ELVI 120V and 220-240V

The load breaker/MCB can be on a different phase than the control breaker/MCB.

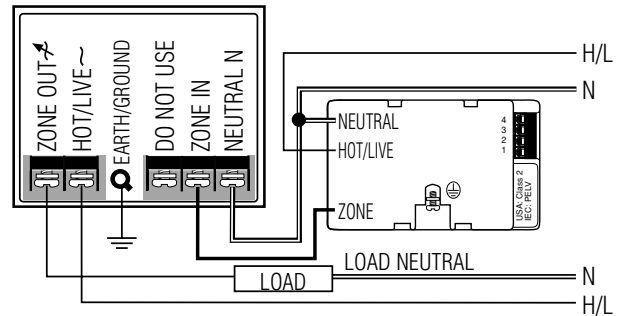

* Wallbox may be flush mounted or surface mounted. If mounting Interface in a panel, please refer to Panel Mounting section for important information.

Dual-Feed Wiring for Two (2) PB/ELVI Interfaces on One Zone - 120V and 220-240V

The load breaker/MCB can be on a different phase than the control breaker/MCB.

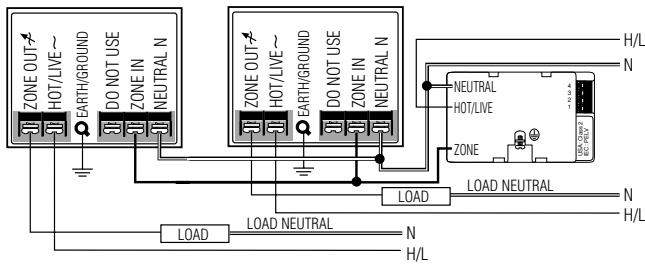

Tu-Wire Dimming Ballast

- When using a **PB** to control a Lutron *Tu-Wire* dimming ballast, the associated zone on the GRAFIK Eye® 3000 Series Control Unit must be set to the *Tu-Wire* load type. Please see the *GRAFIK Eye* 3000 Series Installer's Guide for more details.
- The **PB 230V** must not be used with *Tu-Wire* ballasts because the *Tu-Wire* load type is not available on 230V CE models of the *GRAFIK Eye* Control Unit.

Single-Feed Wiring for PB/ELVI 230V



The **PB/ELVI** may be on the same circuit as the Control Unit *only if* the total load does not exceed the rating of the breaker.

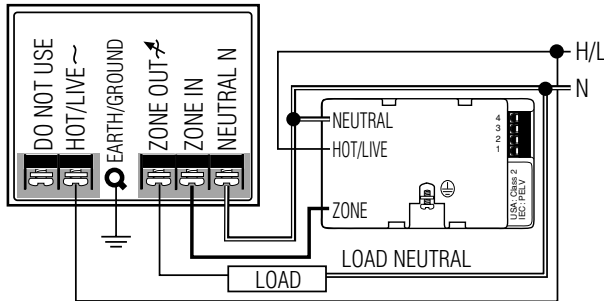

Dual-Feed Wiring for PB/ELVI 230V

The load breaker/MCB can be on a different phase than the control breaker/MCB.

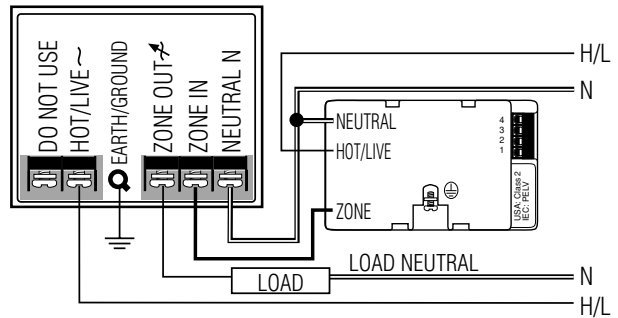

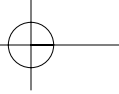

**Single-Feed Wiring for FDBI
120V and 220-240V**



The **FDBI** may be on the same circuit as the Control Unit if, and only if, the total load does not exceed the rating of the breaker. Connect ZONE OUT only to Lutron *Hi-lume* or *Eco-10* Electronic Dimming Ballasts.

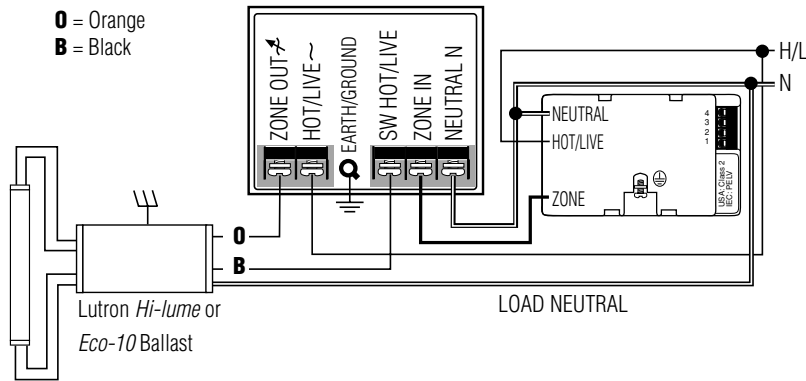

**Dual-Feed Wiring for FDBI
120V and 220-240V**

The load breaker/MCB can be on a different phase than the control breaker/MCB. Connect ZONE OUT only to Lutron *Hi-lume* or *Eco-10* Electronic Dimming Ballasts.

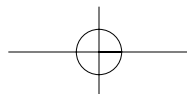
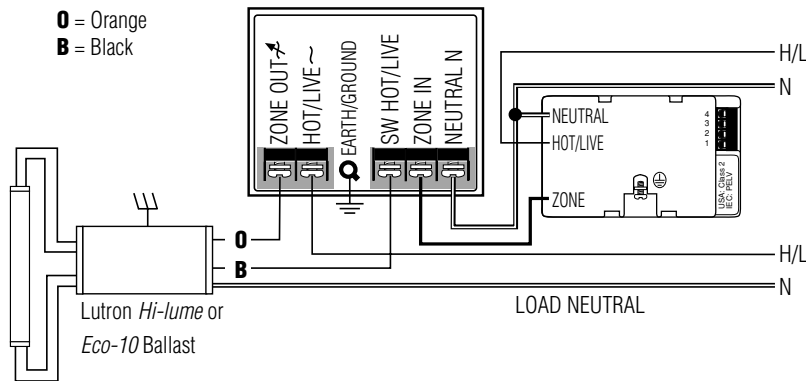

Lutron Products

The following Lutron products can also be used to control your **PB/ELVI/FDBI**:

- *GRAFIK Eye* GP Dimming Panels.
- *GRAFIK Eye* LP Dimming Panels.
- Homeworks Interactive™ Remote Power Panels.
- Lutron fluorescent wallbox dimmers.
- Please contact Lutron for use with other *Homeworks Interactive* or *RadioRA*® dimmers.

Dual-Feed Wiring for Two (2) FDBI Interfaces on One Zone 120V and 220-240V

The load breaker/MCB can be on a different phase than the control breaker/MCB. Connect ZONE OUT only to Lutron *Hi-lume* or *Eco-10* Electronic Dimming Ballasts.

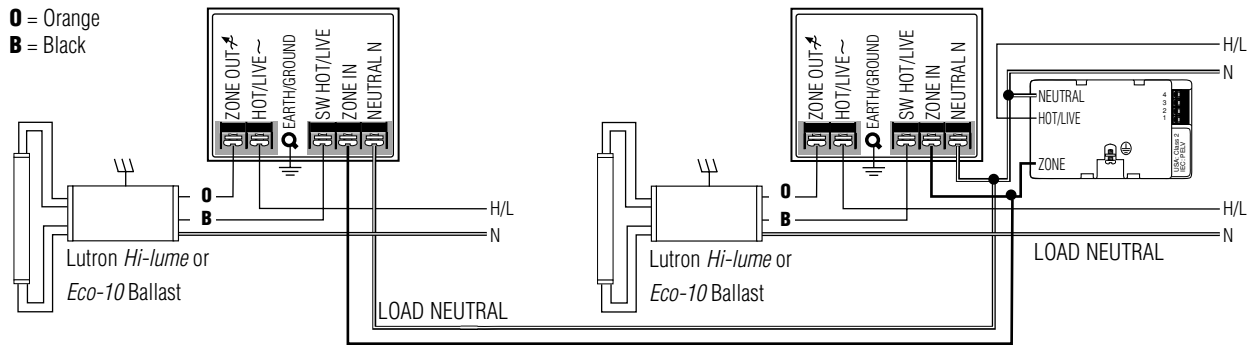

Mounting: Interface must be mounted *vertically*!

1. Confirm all connections and mount the Interface using the screws provided.
2. Restore power to the system.

Flush Mount

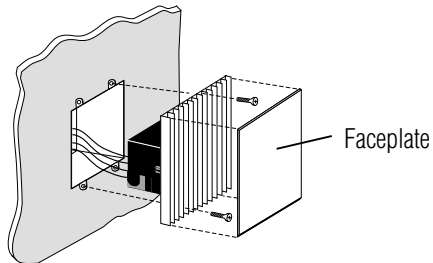

Surface Mount

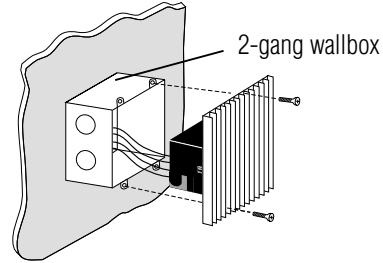



Panel Mounting

- The enclosure must be in accordance with all local and national electrical codes.
- Lutron does not recommend using a door to enclose the front of a panel, since this restricts airflow to the *GRAFIK Eye* Control Units and Interfaces.
- If mounting multiple Control Units or Interfaces in an enclosure:
 1. Ambient temperature within an enclosure **must remain between 32°—104° F (0°—40° C)**.
 2. If not mounting in a metal enclosure, all units **must** be mounted in a wallbox.
- To improve heat dissipation of Power Interfaces, remove the faceplate from the unit.



GRAFIK Eye Control Units and Interface Units dissipate heat when operating. Obstructing these units can cause malfunction to both the Control Unit and the Interface if ambient temperature does not remain between 32°—104° F (0°—40° C).

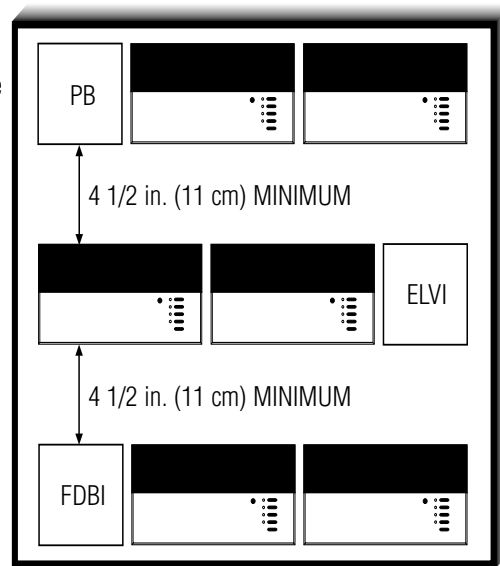

Troubleshooting Guide

Symptom	Causes	Solution
Lights do not come on.	Power is off	Restore power to the PB/ELVI/FDBI . Restore power to the Control Unit.
	Miswire	Confirm wiring per wiring diagrams.
	Bulb(s)/lamp(s) burned out	Replace bulb(s)/lamp(s).
	<i>GRAFIK Eye</i> 3000 Control Unit	Refer to troubleshooting section of <i>GRAFIK Eye</i> Control Unit Installer's Guide.
	Interface is overloaded	Check for excess load, proper mounting, and adequate air convection. Allow unit to cool.
Lights turn on/off unexpectedly.	Load Type	Confirm that the load type being switched/dimmed is compatible with the PB/ELVI/FDBI .
	<i>GRAFIK Eye</i> 3000 Control Unit	Refer to the troubleshooting section of <i>GRAFIK Eye</i> Control Unit Installation Guide.



Internet: www.lutron.com
E-mail: product@lutron.com

WORLD HEADQUARTERS

Lutron Electronics Co. Inc.,
TOLL FREE: (800) 523-9466
(U.S.A., Canada, Caribbean)
Tel: (610) 282-3800;
International 1-610-282-3800
Fax: (610) 282-3090;
International 1-610-282-3090

ASIAN HEADQUARTERS

Lutron Asuka Co, Ltd.,
TOLL FREE: (0120) 083417 (Japan)
Tel: (03) 5405-7333;
International 81-3-5405-7333
Fax: (03) 5405-7496;
International 81-3-5405-7496

EUROPEAN HEADQUARTERS

Lutron EA Ltd.,
FREEPHONE: 0800 282107 (U.K.)
Tel: (207) 702-0657;
International 44-207-702-0657
Fax: (207) 480-6899;
International 44-207-480-6899

HONG KONG SALES OFFICE

Lutron GL (Hong Kong)
Tel: 2104-7733;
International 852-2104-7733
Fax: 2104-7633;
International 852-2104-7633

SINGAPORE

Lutron GL (Singapore)
Tel: 65 220 4666
Fax: 65 220 4333

LIMITED WARRANTY

Lutron will, at its option, repair or replace any unit that is defective in materials or manufacture within one year after purchase. For warranty service, return unit to place of purchase or mail to Lutron at 7200 Suter Rd., Coopersburg, PA 18036-1299, postage pre-paid.

This warranty is in lieu of all other express warranties, and the implied warranty of merchantability is limited to one year from purchase. This warranty does not cover the cost of installation, removal, or reinstallation, or damage resulting from misuse, abuse, or improper or incorrect repair, or damage from improper wiring or installation. This warranty does not cover incidental or consequential damages. Lutron's liability on any claim for damages arising out of or in connection with the manufacture, sale, installation, delivery, or use of the unit shall never exceed the purchase price of the unit.

This warranty gives you specific legal rights, and you may also have other rights which vary from state to state. Some states do not allow limitations on how long an implied warranty lasts, so the above limitation may not apply to you. Some states do not allow the exclusion or limitation of incidental or consequential damages, so the above limitation or exclusion may not apply to you.

This product may be covered by one or more of the following U.S. patents: 4,797,599; 4,803,380; and corresponding foreign patents.

Lutron, GRAFIK Eye, Hi-lume, Homeworks, Radio RA, and Tu-Wire are registered trademarks, and Eco-10, Tu-Wire, and Homeworks Interactive are trademarks of Lutron Electronics Co., Inc.

© 2002 Lutron Electronics Co., Inc.

LUTRON®

Lutron Electronics Co., Inc.
Made and printed in U.S.A.
P/N 030-739 Rev. A 2/02

Power Modules Installation Instructions

Please Read



Phase-Adaptive
Power Module



3-Wire Fluorescent
Power Module



Switching
Power Module

Models and Capacities

Module Type	Control	Load	Load Capacity	Model Number
Phase-Adaptive	120 V \sim	120 - 277 V \sim	16 A	PHPM-PA-DV-WH
	50 / 60 Hz	50 / 60 Hz		
Phase-Adaptive	120 V \sim	120 V \sim	16 A	PHPM-PA-120-WH
	50 / 60 Hz	50 / 60 Hz		
3-Wire Fluorescent	120 V \sim	120 - 277 V \sim	16 A	PHPM-3F-DV-WH
	50 / 60 Hz	50 / 60 Hz		
3-Wire Fluorescent	120 V \sim	120 V \sim	16 A	PHPM-3F-120-WH
	50 / 60 Hz	50 / 60 Hz		
Switching	120 V \sim	120 - 277 V \sim	16 A	PHPM-SW-DV-WH
	50 / 60 Hz	50 / 60 Hz		

General Notes



Danger! Always turn OFF the circuit breakers or remove the main fuses from the power line before doing any work. Failure to do so can result in serious personal injury. More than one disconnect may be required to de-energize this device. Disconnect all power sources before servicing unit.

- This power module must be installed by a qualified electrician in accordance with all applicable regulations.
- Improper wiring can result in personal injury, damage to the interface, or damage to other equipment.
- Up to three power modules per zone.
- The power module must be mounted with arrow facing upward to ensure adequate cooling.
- CAUTION! Dimmed magnetic low-voltage transformers: To avoid excessively high current flow that can cause transformer overheating and failure, observe the following:
 - (a) Do not operate the power module with all of the lamps removed or with any lamps inoperative.
 - (b) Replace any burned out lamps immediately.
 - (c) Use only transformers that incorporate thermal protection or fused primary windings.

- Phase-Adaptive/Fluorescent: These power modules contain circuitry that will shut down the output if it is overloaded. To correct the problem, turn off power and reduce the load to the specified rating before re-applying power.



Note! Plastic faceplate must be installed on module for normal operation (all models).

Load Type Capability

Switching Power Module:

- Incandescent (tungsten)
- Halogen
- Magnetic low-voltage transformer (iron core)
- Electronic (solid-state) low-voltage transformer.
- Magnetic and electronic fluorescent lamp ballasts
- Neon/cold-cathode
- HID
- Motor
 - 1/2 HP at 277 V \sim
 - 1/3 HP at 120 V \sim

Phase-Adaptive Power Module:

- Incandescent (tungsten)
- Halogen
- Magnetic low-voltage transformer (iron core)
- Electronic (solid-state) low-voltage transformer
- Lutron Tu-Wire™ electronic fluorescent dimming ballast
- Neon/cold-cathode

3-Wire Fluorescent Power Module:

- Lutron *Hi-Lume* and *Eco-10* (Eco Series) line-voltage control electronic dimming ballasts

Product Compatibility

The following Lutron products may be used to control these power modules:

- *GRAFIK Eye* QS control units
- *GRAFIK Eye* 3000 Series control units
- LP, LCP, GP dimming panels
- *HomeWorks* remote power panels

Test Load for Short-Circuit

- Turn power Off.
- Phase-Adaptive/Switching: Connect standard switch between Hot/Live lead and the load wire to test circuit.
- Fluorescent: Connect standard switch between Hot/Live lead and the Dimmed Hot/Live and switched Hot/Live leads of the ballast.
- Turn power On and check for short or open circuits.

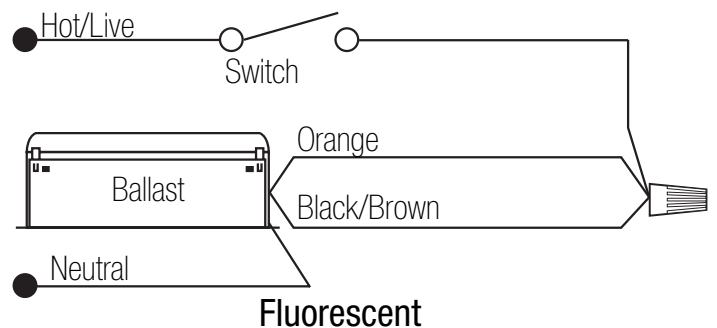
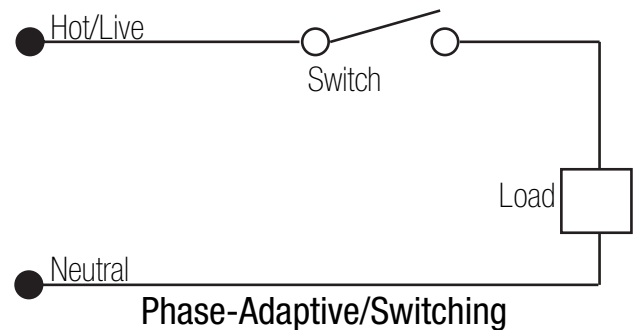

Wiring

- Mount in 2-gang U.S. wallbox 3.5 in. (89 mm) deep or 4 x 4 in. (102 mm) junction box 2.1 in. deep (53 mm). Indoors only.
- This device generates heat; mount only where ambient temperature is 32 - 104 °F (0 - 40 °C).
- Mount with arrows facing up to ensure adequate cooling.
- Allow 4.5 in. (114 mm) above and below unit and between faceplates when mounting several in a vertical layout.
- Mount so line (mains) voltage wiring is at least 6 ft. (1.8 m) from sound or electronic equipment and wiring.
- Mount within 7° of true vertical.

- Provide #12 AWG (2.5 mm²) copper (Cu) wires (75 °C minimum) for input power and load circuit.
- Strip 1/2 in. (12 mm) insulation from wires before connecting.
- Run separate neutral for load circuit - no common neutrals.



Note! Plastic faceplate must be installed on module for normal operation (all models).

Dimensions

All Modules: Front View

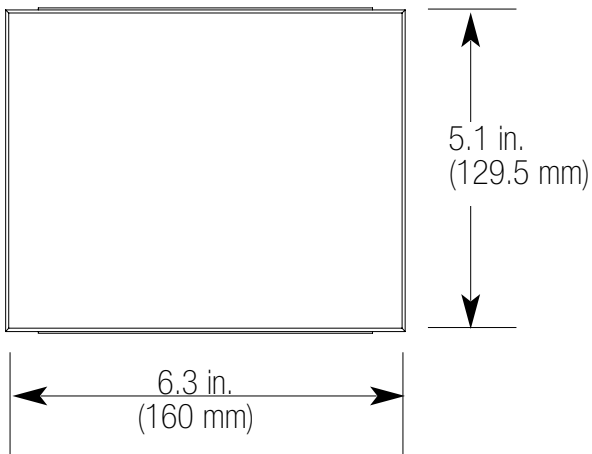

Switching and
3-Wire Fluorescent Modules:
Side View

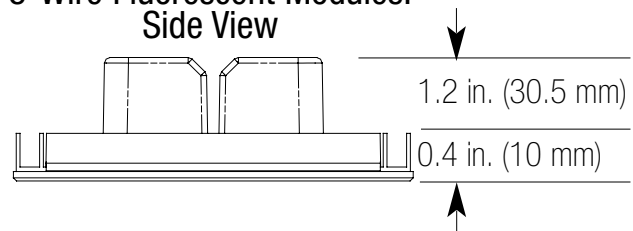

Phase-Adaptive Module:
Side View

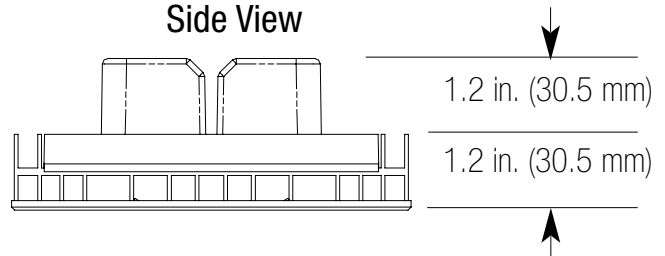

Mounting Methods

Mount to 2-gang U.S. wallbox

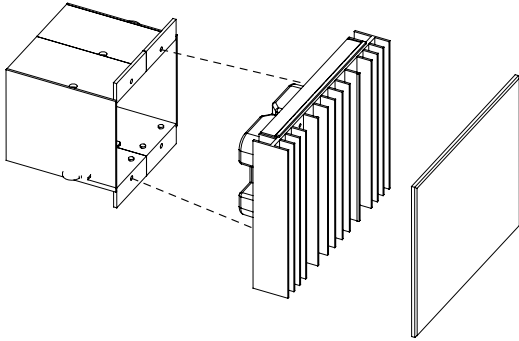

Mount to 4 x 4 in. (102 mm), 2.1 in. (53 mm) deep U.S. junction box

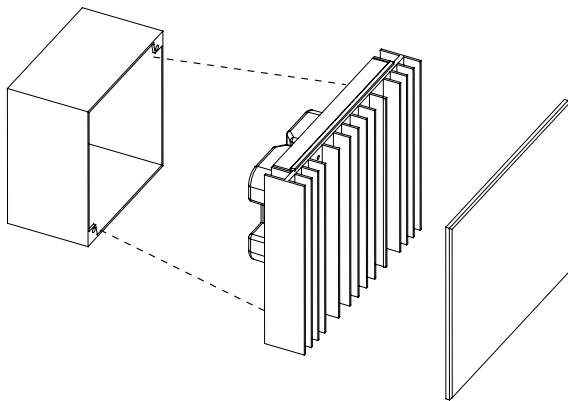

Mount to 4 x 4 in. (102 mm), 2.1 in. (53 mm) deep U.S. junction box with barrier (for 277 V_~ loads if required by local electrical code)

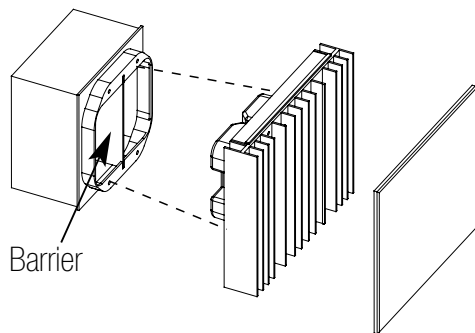

Mounting Inside an Enclosure with GRAFIK Eye Control Units

- Mount in accordance with all local and national electrical codes.
- Proper ventilation is required. Ambient temperature inside enclosure must remain between 32 - 104 °F (0 - 40 °C) when GRAFIK Eye control units and power modules are operating.
- See diagram below for required spacing between units.

Note! Plastic faceplate must be installed on module for normal operation (all models).

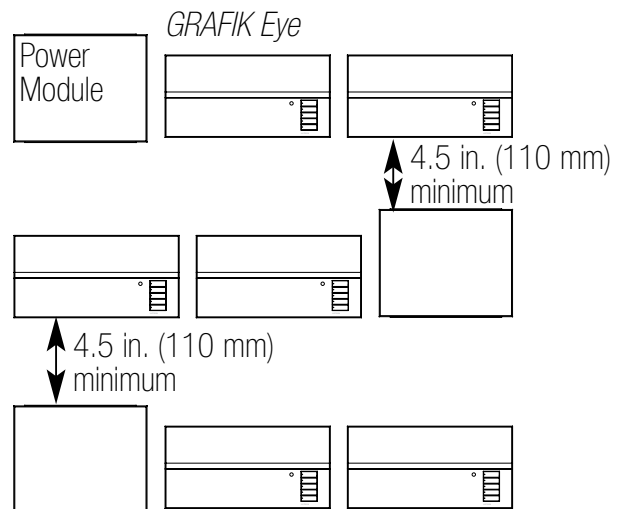

Single-Feed Wiring

The power module may be on the same circuit as the control unit only if the total load does not exceed the rating of the branch circuit breaker in accordance with local and national electrical codes.

Phase-Adaptive Module Wiring

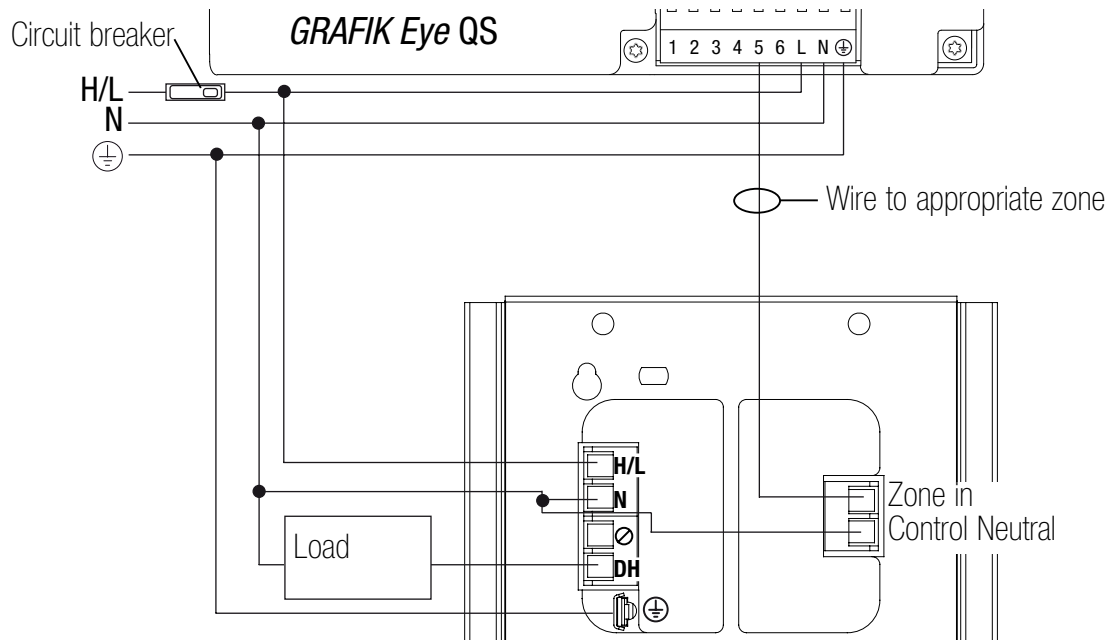

Legend

- H/L Hot/Live
- N Neutral
- SH Switched Hot
- DH Dimmed Hot
- ⊕ Ground
- ⊘ Not Used

Fluorescent 3-Wire Module Wiring

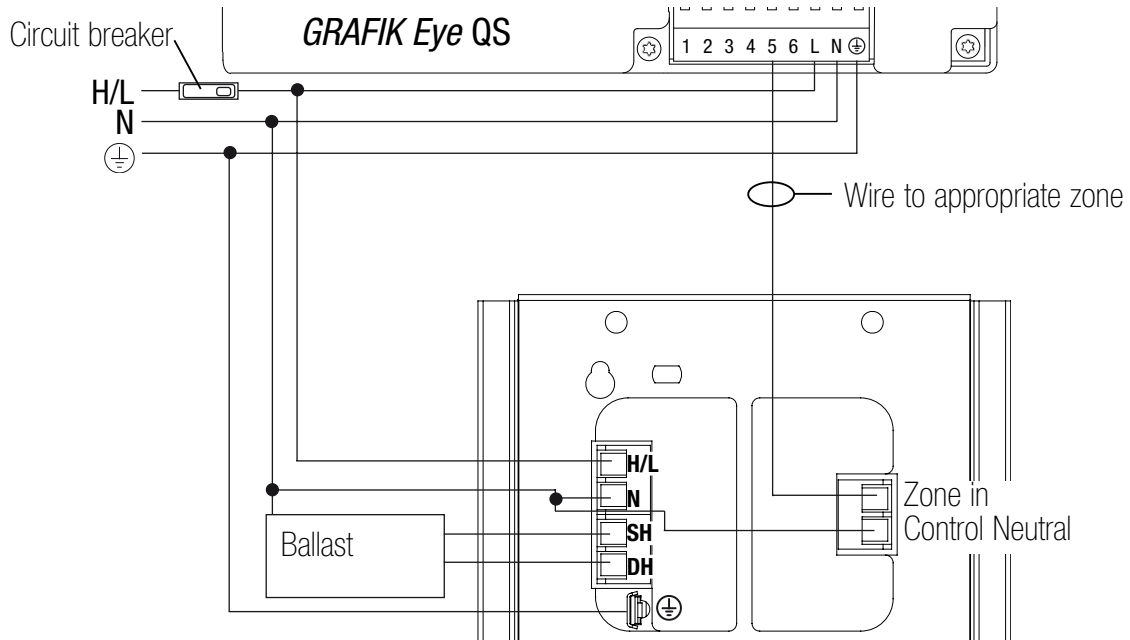

Switching Module Wiring

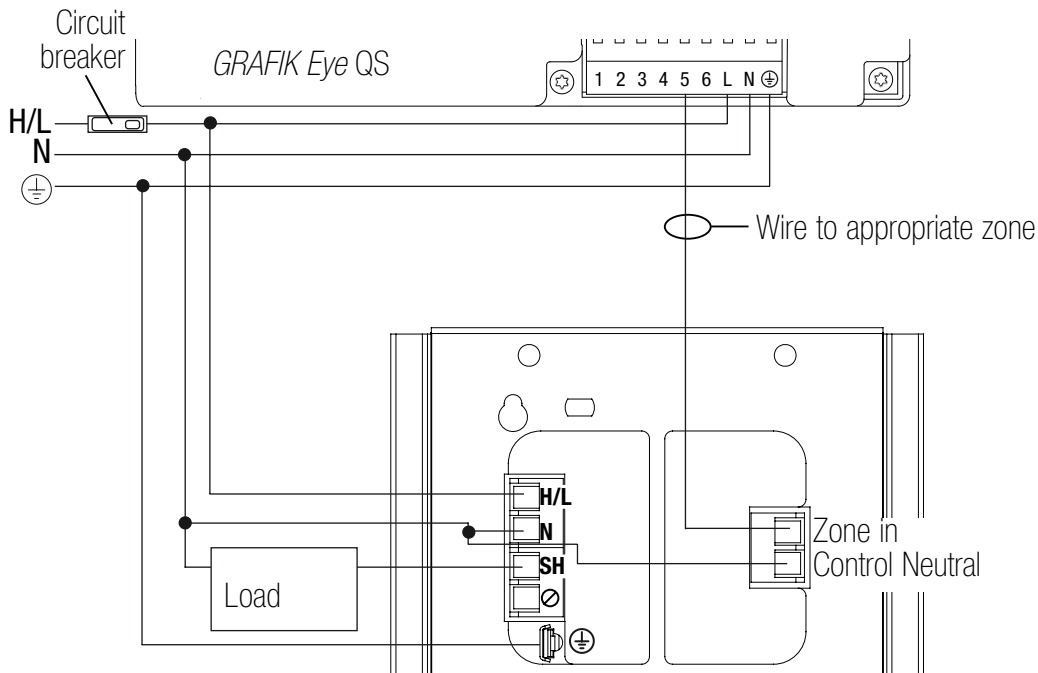

Dual-Feed Wiring

The load breaker can be on a different phase than the control breaker. Both breakers must be turned off prior to installing or servicing the module.

Phase-Adaptive Module Wiring

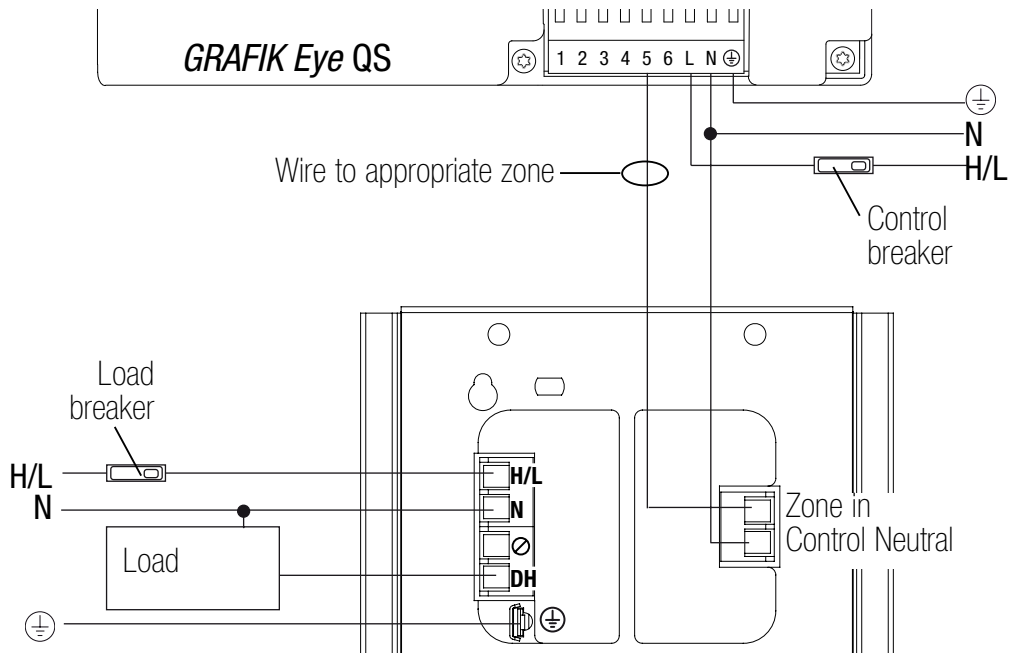

Legend

- H/L Hot/Live
- N Neutral
- SH Switched Hot
- DH Dimmed Hot
- ⊕ Ground
- ⊘ Not Used

Fluorescent 3-Wire Module Wiring

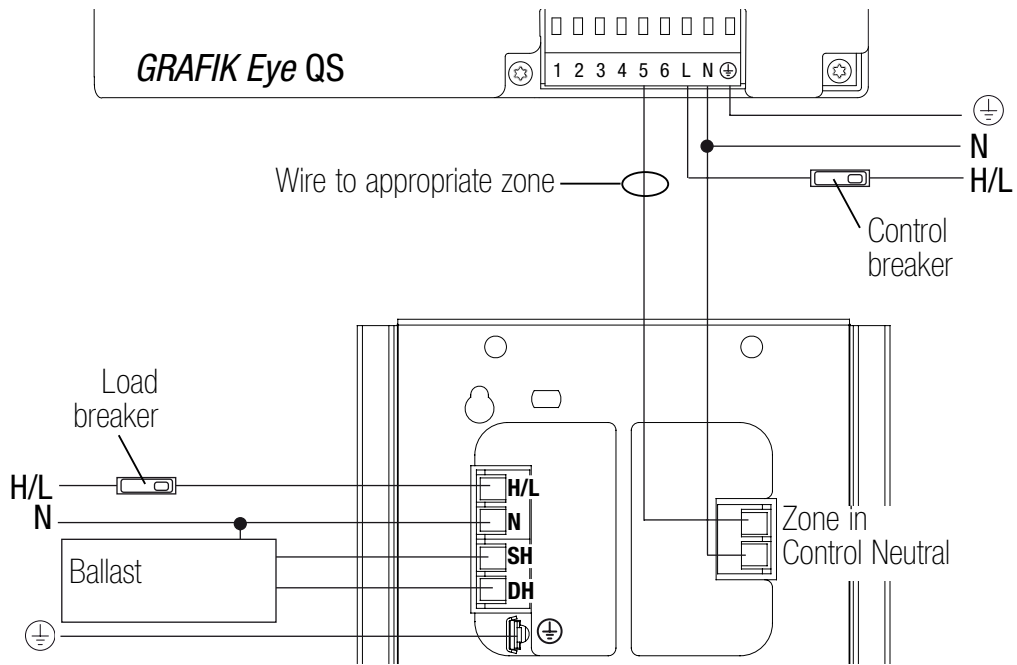

Switching Module Wiring

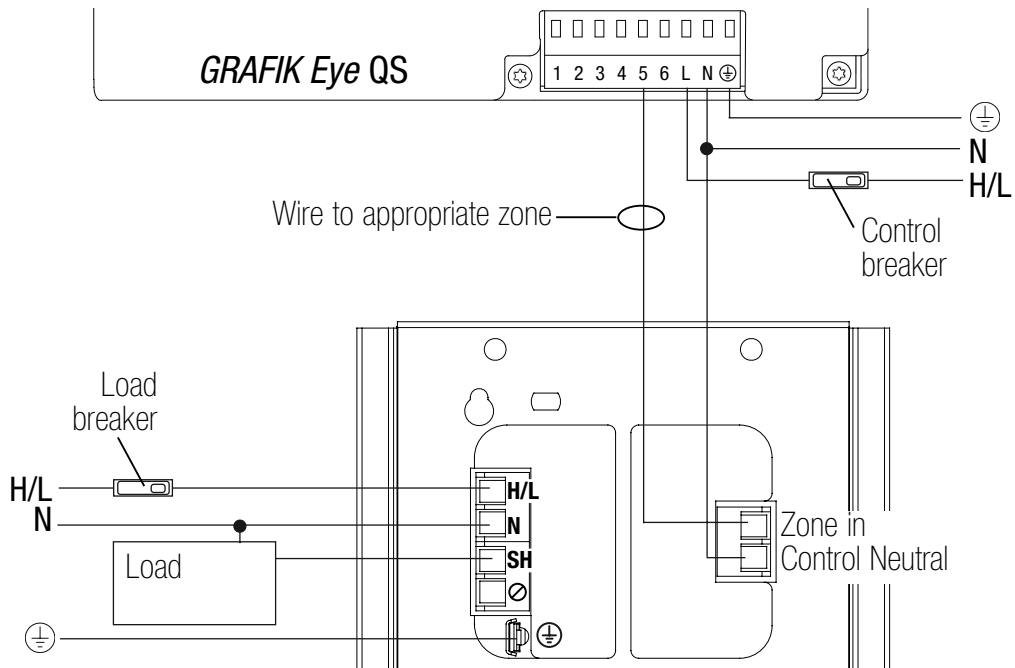

PHASE-ADAPTIVE POWER MODULE DIAGNOSTICS AND TROUBLESHOOTING

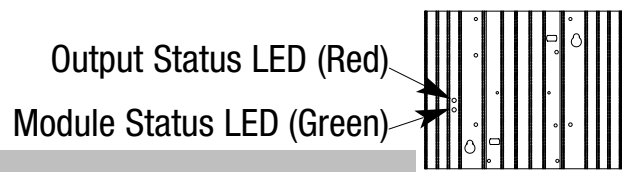

Module Status LED (green)	
LED Action	Comments
Off	Module not powered. Caution: Control input may still be powered. Turn off all breakers before removing unit.
1 blink/second (“heartbeat”)	Module powered; normal operation

Output Status LED (red)			
LED Action	Control Input Status	Load Status	Comments
Off	Input signal off or disconnected	Off	Load off
Continuously on	On	On	Incandescent/electronic dimming
1 blink/second (“heartbeat”)	On	On	Magnetic dimming
1 blink, pause, repeat	On	Off	Load short-circuit/overload ¹
2 blinks, pause, repeat	On	Off	Over-voltage error ²
3 blinks, pause, repeat	On	On full	Shorted component ³
4 blinks, pause, repeat	On	Off	DC detection ⁴

¹Remove power; repair fault; re-apply power.

²Verify proper load on output.

³Replace power module; internal device is damaged.

⁴Possible faulty MLV load.

3-WIRE FLUORESCENT POWER MODULE DIAGNOSTICS AND TROUBLESHOOTING

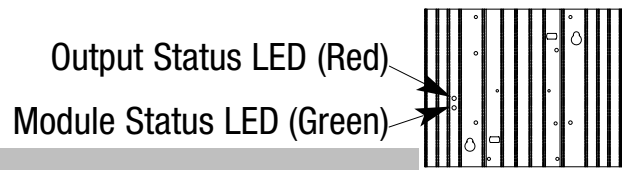

Module Status LED (green)	
LED Action	Comments
Off	Module not powered. Caution: Control input may still be powered. Turn off all breakers before removing unit.
1 blink/second (“heartbeat”)	Module powered; normal operation

Output Status LED (red)			
LED Action	Control Input Status	Load Status	Comments
Off	Input signal off or disconnected	Off	Load off
Continuously on	On	On	Load on. Note: Output may repeatedly turn on and off if DH is overloaded or if DH and SH are miswired.

SWITCHING POWER MODULE DIAGNOSTICS AND TROUBLESHOOTING

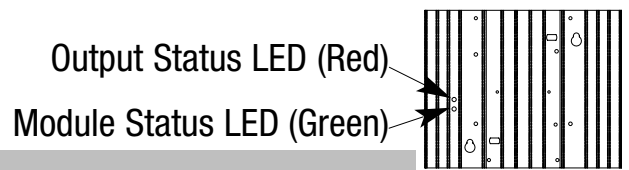

Module Status LED (green)	
LED Action	Comments
Off	Module not powered. Caution: Control input may still be powered. Turn off all breakers before removing unit.
1 blink/second (“heartbeat”)	Module powered; normal operation

Output Status LED (red)			
LED Action	Control Input Status	Load Status	Comments
Off	Input signal off or disconnected	Off	Load off
Continuously on	On	On	Load on

Internet: www.lutron.com
E-mail: product@lutron.com

WORLD HEADQUARTERS

Lutron Electronics Co., Inc.
7200 Suter Road, Coopersburg, PA
18036-1299 USA
TEL +1.610.282.3800
FAX +1.610.282.1243
Technical Support 1.800.523.9466
Toll-Free 1.888.LUTRON1

EUROPEAN HEADQUARTERS

United Kingdom

Lutron EA Ltd.
6 Sovereign Close, London, E1W 3JF UK
TEL +44.(0)20.7702.0657
FAX +44.(0)20.7480.6899
Technical support +44.(0)20.7680.4481
FREEPHONE 0800.282.107

ASIAN HEADQUARTERS

Singapore

Lutron GL Ltd.
15 Hoe Chiang Road,
#07-03 Euro Asia Centre,
Singapore 089316
TEL +65.6220.4666
FAX +65.6220.4333

Asia Technical Hotlines

Northern China: 10.800.712.1536
Southern China: 10.800.120.1536
Hong Kong: 800.901.849
Indonesia : 001.803.011.3994
Japan: +81.3.5575.8411
Macau : 0800.401
Singapore: 800.120.4491
Taiwan: 00.801.137.737
Thailand: 001.800.120.665853
Other Areas: +65.6220.4666

Lutron Electronics Co., Inc. One Year Limited Warranty

For a period of one year from the date of purchase, and subject to the exclusions and restrictions described below, Lutron warrants each new unit to be free from manufacturing defects. Lutron will, at its option, either repair the defective unit or issue a credit equal to the purchase price of the defective unit to the Customer against the purchase price of comparable replacement part purchased from Lutron. Replacements for the unit provided by Lutron or, at its sole discretion, an approved vendor may be new, used, repaired, reconditioned, and/or made by a different manufacturer.

If the unit is commissioned by Lutron or a Lutron approved third party as part of a Lutron commissioned lighting control system, the term of this warranty will be extended, and any credits against the cost of replacement parts will be prorated, in accordance with the warranty issued with the commissioned system, except that the term of the unit's warranty term will be measured from the date of its commissioning.

EXCLUSIONS AND RESTRICTIONS

This Warranty does not cover, and Lutron and its suppliers are not responsible for:

1. Damage, malfunction or inoperability diagnosed by Lutron or a Lutron approved third party as caused by normal wear and tear, abuse, misuse, incorrect installation, neglect, accident, interference or environmental factors, such as (a) use of incorrect line voltages, fuses or circuit breakers; (b) failure to install, maintain and operate the unit pursuant to the operating instructions provided by Lutron and the applicable provisions of the National Electrical Code and of the Safety Standards of Underwriter's Laboratories; (c) use of incompatible devices or accessories; (d) improper or insufficient ventilation; (e) unauthorized repairs or adjustments; (f) vandalism; or (g) an act of God, such as fire, lightning, flooding, tornado, earthquake, hurricane or other problems beyond Lutron's control.
2. On-site labor costs to diagnose issues with, and to remove, repair, replace, adjust, reinstall and/or reprogram the unit or any of its components.
3. Equipment and parts external to the unit, including those sold or supplied by Lutron (which may be covered by a separate warranty).
4. The cost of repairing or replacing other property that is damaged when the unit does not work properly, even if the damage was caused by the unit.

EXCEPT AS EXPRESSLY PROVIDED IN THIS WARRANTY, THERE ARE NO EXPRESS OR IMPLIED WARRANTIES OF ANY TYPE, INCLUDING ANY IMPLIED WARRANTIES OF FITNESS FOR A PARTICULAR PURPOSE OR MERCHANTABILITY. LUTRON DOES NOT WARRANT THAT THE UNIT WILL OPERATE WITHOUT INTERRUPTION OR BE ERROR FREE.

NO LUTRON AGENT, EMPLOYEE OR REPRESENTATIVE HAS ANY AUTHORITY TO BIND LUTRON TO ANY AFFIRMATION, REPRESENTATION OR WARRANTY CONCERNING THE UNIT. UNLESS AN AFFIRMATION, REPRESENTATION OR WARRANTY MADE BY AN AGENT, EMPLOYEE OR REPRESENTATIVE IS SPECIFICALLY INCLUDED HEREIN, OR IN STANDARD PRINTED MATERIALS PROVIDED BY LUTRON, IT DOES NOT FORM A PART OF THE BASIS OF ANY BARGAIN BETWEEN LUTRON AND CUSTOMER AND WILL NOT IN ANY WAY BE ENFORCEABLE BY CUSTOMER.

IN NO EVENT WILL LUTRON OR ANY OTHER PARTY BE LIABLE FOR EXEMPLARY, CONSEQUENTIAL, INCIDENTAL OR SPECIAL DAMAGES (INCLUDING, BUT NOT LIMITED TO, DAMAGES FOR LOSS OF PROFITS, CONFIDENTIAL OR OTHER INFORMATION, OR PRIVACY; BUSINESS INTERRUPTION; PERSONAL INJURY; FAILURE TO MEET ANY DUTY, INCLUDING OF GOOD FAITH OR OF REASONABLE CARE; NEGLIGENCE, OR ANY OTHER PECUNIARY OR OTHER LOSS WHATSOEVER), NOR FOR ANY REPAIR WORK UNDERTAKEN WITHOUT LUTRON'S WRITTEN CONSENT ARISING OUT OF OR IN ANY WAY RELATED TO THE INSTALLATION, DEINSTALLATION, USE OF OR INABILITY TO USE THE UNIT OR OTHERWISE UNDER OR IN CONNECTION WITH ANY PROVISION OF THIS WARRANTY, OR ANY AGREEMENT INCORPORATING THIS WARRANTY, EVEN IN THE EVENT OF THE FAULT, TORT (INCLUDING NEGLIGENCE), STRICT LIABILITY, BREACH OF CONTRACT OR BREACH OF WARRANTY OF LUTRON OR ANY SUPPLIER, AND EVEN IF LUTRON OR ANY OTHER PARTY WAS ADVISED OF THE POSSIBILITY OF SUCH DAMAGES.

NOTWITHSTANDING ANY DAMAGES THAT CUSTOMER MIGHT INCUR FOR ANY REASON WHATSOEVER (INCLUDING, WITHOUT LIMITATION, ALL DIRECT DAMAGES AND ALL DAMAGES LISTED ABOVE), THE ENTIRE LIABILITY OF LUTRON AND OF ALL OTHER PARTIES UNDER THIS WARRANTY ON ANY CLAIM FOR DAMAGES ARISING OUT OF OR IN CONNECTION WITH THE MANUFACTURE, SALE, INSTALLATION, DELIVERY, USE, REPAIR, OR REPLACEMENT OF THE UNIT, OR ANY AGREEMENT INCORPORATING THIS WARRANTY, AND CUSTOMER'S SOLE REMEDY FOR THE FOREGOING, WILL BE LIMITED TO THE AMOUNT PAID TO LUTRON BY CUSTOMER FOR THE UNIT. THE FOREGOING LIMITATIONS, EXCLUSIONS AND DISCLAIMERS WILL APPLY TO THE MAXIMUM EXTENT ALLOWED BY APPLICABLE LAW, EVEN IF ANY REMEDY FAILS ITS ESSENTIAL PURPOSE.

TO MAKE A WARRANTY CLAIM

To make a warranty claim, promptly notify Lutron within the warranty period described above by calling the Lutron Technical Support Center at (800) 523-9466. Lutron, in its sole discretion, will determine what action, if any, is required under this warranty. To better enable Lutron to address a warranty claim, have the unit's serial and model numbers available when making the call. If Lutron, in its sole discretion, determines that an on-site visit or other remedial action is necessary, Lutron may send a Lutron Services Co. representative or coordinate the dispatch of a representative from a Lutron approved vendor to Customer's site, and/or coordinate a warranty service call between Customer and a Lutron approved vendor.

This warranty gives you specific legal rights, and you may also have other rights which vary from state to state. Some states do not allow limitations on how long an implied warranty lasts, so the above limitation may not apply to you. Some states do not allow the exclusion or limitation of incidental or consequential damages, so the above limitation or exclusion may not apply to you.

These products may be covered under one or more of the following U.S. patents: 4,797,599; 5,309,068; 5,633,540; 6,091,205; 6,380,692; and corresponding foreign patents. U.S. and foreign patents pending.

Lutron, the sunburst logo, and GRAFIK Eye are registered trademarks and Tu-Wire is a trademark of Lutron Electronics Co., Inc.
© 2007 Lutron Electronics Co., Inc.

Lutron Electronics Co., Inc.
Made and printed in U.S.A.
P/N 032-178 Rev. A 4/07



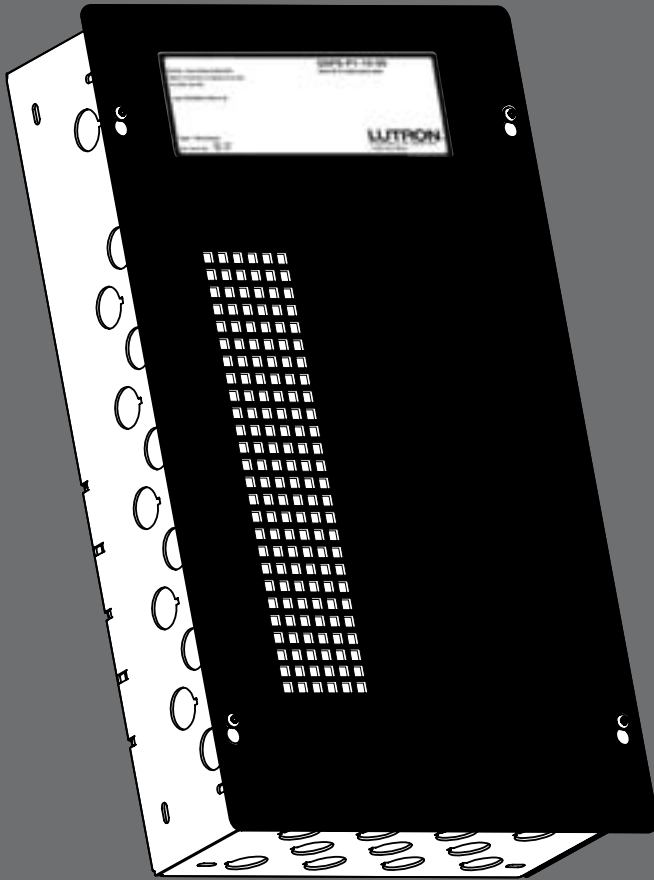

QS® Smart Power Supply Panel

Installation
Instructions

QSPS-P1-10-60

 **LUTRON®**

QSPS-P1-10-60

120 V~ 60 Hz

5 A Max Input Current

Installation Instructions (Please leave for occupant)

Please read before installing.

Tools Required:

Wire Cutter/Stripper

Power Drill

Small Flat-Head Screwdriver

#2 Phillips Screwdriver

NOTE: Mounting hardware is not included due to the wide variety of wall materials.

Customer should determine the appropriate mounting hardware for their specific needs.

Box Contents:

QSPS-P1-10-60

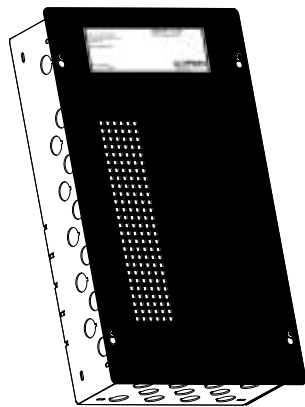

1

Important Notes



Adherence to these specifications is necessary to ensure a safe and successful installation.

1.1

1. All wiring must be in accordance with national and local electrical codes.
2. QSPS-P1-10-60 must be installed by a qualified electrician.
3. Ambient operating temperature: 32 - 104 °F (0 - 40 °C), 0 - 90% humidity, non-condensing.
4. This product is intended for **indoor use only**.
5. Separate over current protection is required to be provided in accordance with Canadian Electrical Code, Part 1.

2 Installation

2.1

1. **Mount QSPS-P1-10-60** using one of the following methods (Mounting Hardware is not provided) Do not mount in any other orientation.
 - a. **Surface Mount** - Use the keyholes located on the back of the enclosure to fasten the QSPS-P1-10-60 to the wall. Use fasteners rated for a 50 lb. (23 kg) load. See illustration of QSPS-P1-10-60 .
 - b. **Recess Mount** - Install a 2 in x 4 in (50 mm x 100 mm) board between the studs as a bottom support. Fasten the QSPS-P1-10-60 to the right stud and bottom support inserting fasteners through the mounting holes provided.



CAUTION -

The equipment is air-cooled. Mount in a location where the vented cover will not be blocked. A minimum of 1 ft. (300 mm) is necessary.



DANGER -

Locate and lock the supply breaker in the OFF position before wiring to the terminal blocks.

2. **Connect 120 V~ power wiring into the QSPS-P1-10-60.**

Remove one of the knockout tabs on the top left side of the enclosure near the input terminal blocks. Insert a strain relief into the knockout hole. Run the power wire through the strain relief to the input terminal blocks at the top left side of the enclosure. Tighten terminal blocks to 3.5 to 5 in-lbs. (0.4-0.6 N•m).

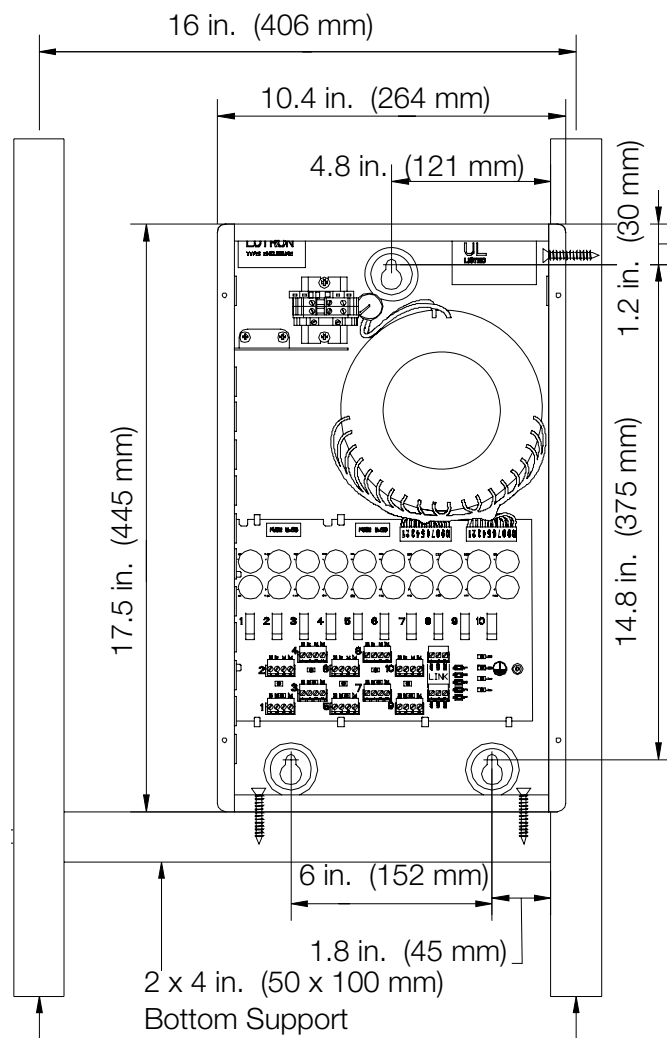

Note: Maximum of 1 QSPS-P1-10-60 per 15 A Breaker.
Maximum of 2 QSPS-P1-10-60 per 20 A Breaker.
Maximum feed breaker size of 30 Amps.
Use only High-Magnetic breakers.

2 Installation (continued)

2.2 QSPS-P1-10-60 Parts identification

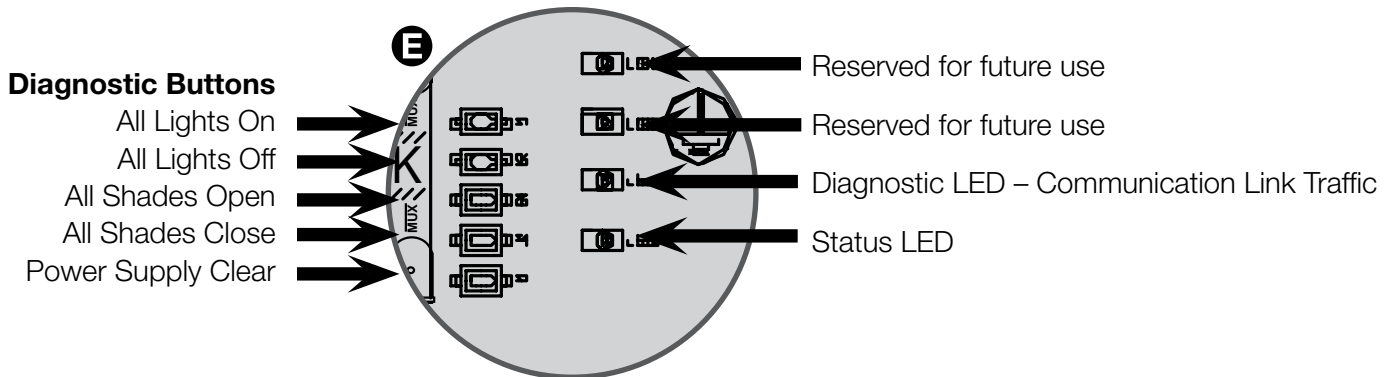
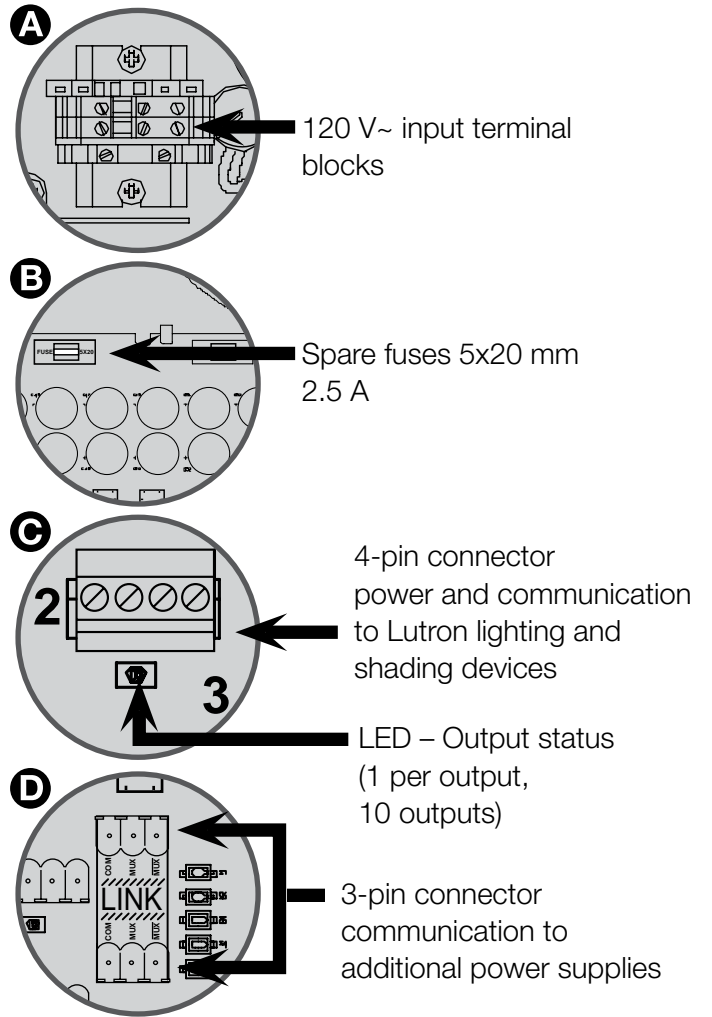
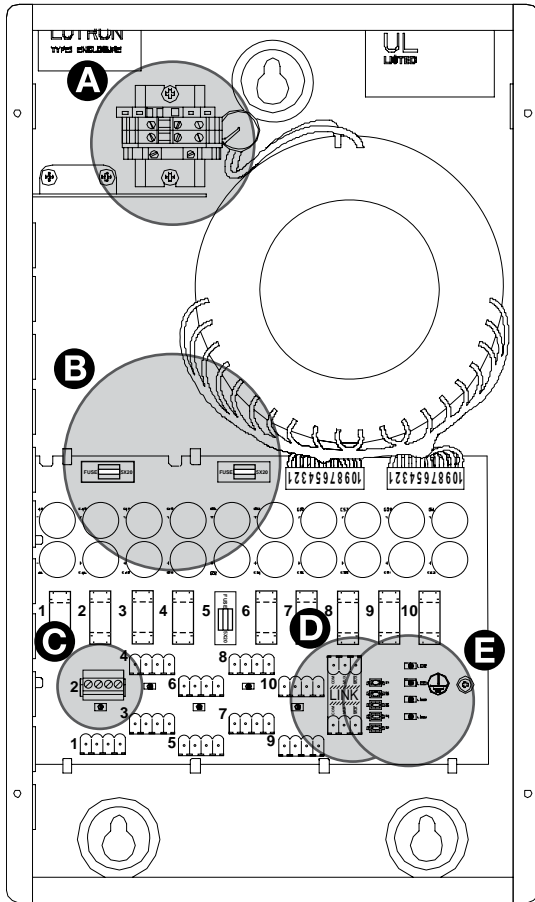

3 QS Link Wiring

3.1 Link Rules

The following Link rules must be observed for proper operation.

- Maximum of 100 devices (such as a GRAFIK Eye® QS, QS keypad, QSPS-P1-10-60, or Sivoia® QS shade)
- Maximum of 100 zones (such as a Sivoia QS shade, or a lighting zone on a GRAFIK Eye QS)
- Maximum 2,000 ft (600 m) of cable connecting all QSPS-P1-10-60 panels
- Maximum 2,000 ft (600 m) of cable to devices wired to each QSPS-P1-10-60
- Use only cable with at least one twisted/shielded pair for communications (MUX and MUX)

3.2 Wire Length Chart

Maximum devices per one output		Maximum distance per one output based on wire guage		
Shades + Controls		#12 AWG (4 mm ²)	#16 AWG (1.5 mm ²)	#18 AWG (1 mm ²) GRX-CBL-346S-500
None	Up to 6 seeTouch QS keypads	1000 ft. (300 m)	500 ft. (150 m)	250 ft. (75 m)
1 Sivoia QS roller 64™	None	500 ft. (150 m)	200 ft. (60 m)	100 ft. (30 m)
1 Sivoia QS roller 64	Up to 2 seeTouch QS keypads	250 ft. (75 m)	75 ft. (20 m)	50 ft. (15 m)
2 Sivoia QS roller 64, ≤ 30 sq ft (2.75 sq m) each	None	250 ft. (75 m)	75 ft. (20 m)	50 ft. (15 m)
3 Sivoia QS roller64, ≤ 20 sq ft (1.8 sq m) each	None	250 ft. (75 m)	75 ft. (20 m)	50 ft. (15 m)

3

QS Link Wiring (continued)

3.3 Example: Multiple shades per output

Sivoia QS roller 64, 25 sq. ft. (2.25 sq. m)

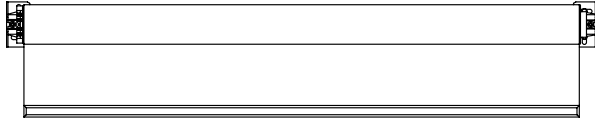

Sivoia QS roller 64, 25 sq. ft. (2.25 sq. m)

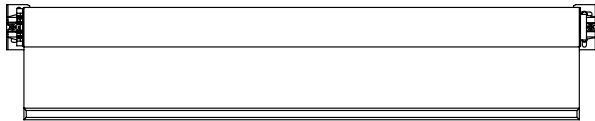

Up to 50 ft (15 m) of
#18 AWG (1 mm²)
4-conductor twisted/
shielded wire



seeTouch® QS



Up to 250 ft (75 m) of
#18 AWG (1 mm²)
4-conductor twisted/
shielded wire

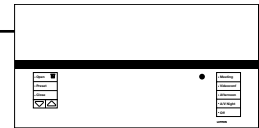
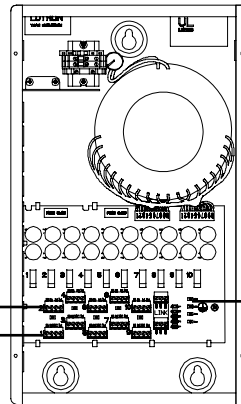

GRAFIK Eye® QS

3.4 Example: One shade per output

Sivoia QS roller 64, 25 sq. ft. (2.25 sq. m)

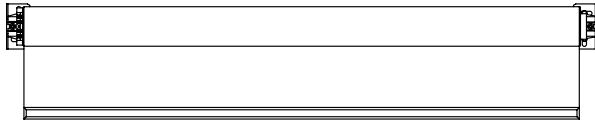

Sivoia QS roller 64, 25 sq. ft. (2.25 sq. m)

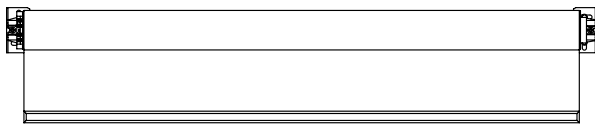

Up to 100 ft (30 m) of
#18 AWG (1 mm²)
4-conductor twisted/
shielded wire

Up to 100 ft (30 m) of
#18 AWG (1 mm²)
4-conductor
twisted/shielded wire



seeTouch® QS



Up to 250 ft (75 m) of
#18 AWG (1 mm²)
4-conductor twisted/
shielded wire

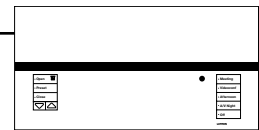
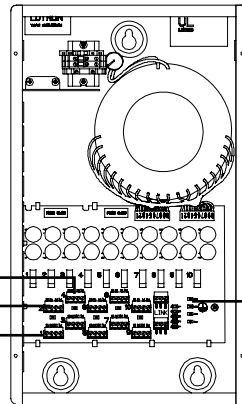

GRAFIK Eye® QS

4 Wiring the QSPS-P1-10-60

4.1 Run low voltage wire into the QSPS-P1-60

Remove as many knockout tabs as necessary from the left side of the enclosure and insert strain reliefs.

Run the low-voltage communication wiring from the Lutron QS shade and lighting devices through the strain reliefs to the terminal blocks.

Strip insulation wire so that .25 in. (7 mm) of bare wire is exposed. Make sure to tighten the screws tightly and that no insulation is inside of the terminal block.

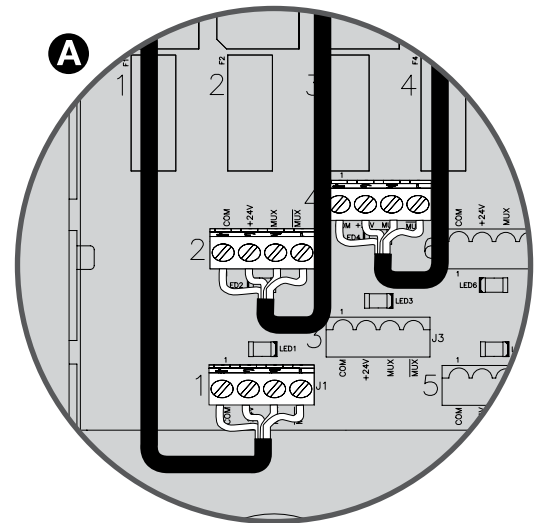
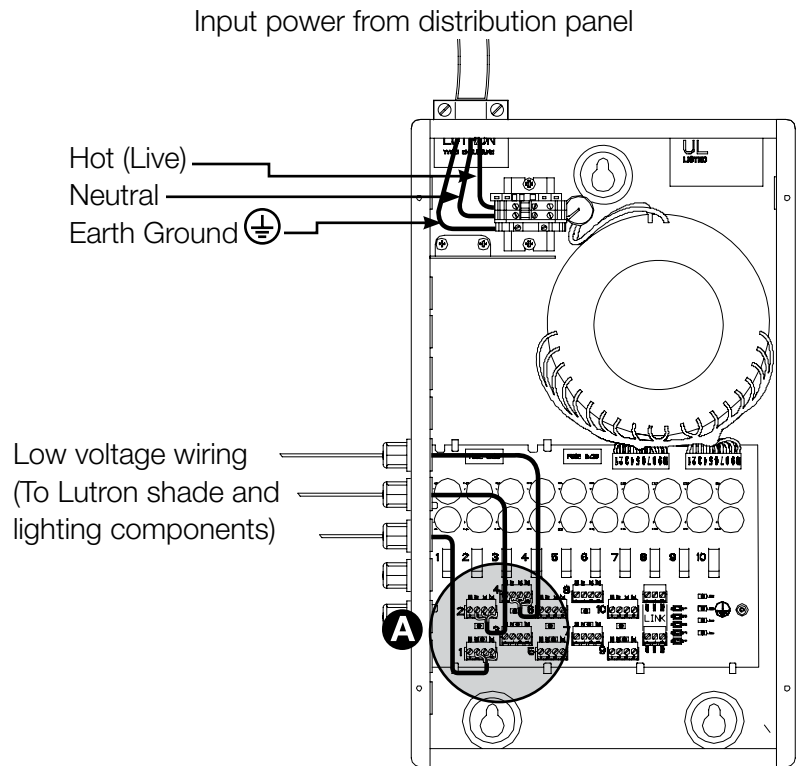

4

Wiring the QSPS-P1-10-60 (continued)

4.2 Connecting Multiple QSPS-P1-10-60 Panels

Use the two 3-pin terminal blocks when connecting multiple QSPS-P1-10-60 panels.

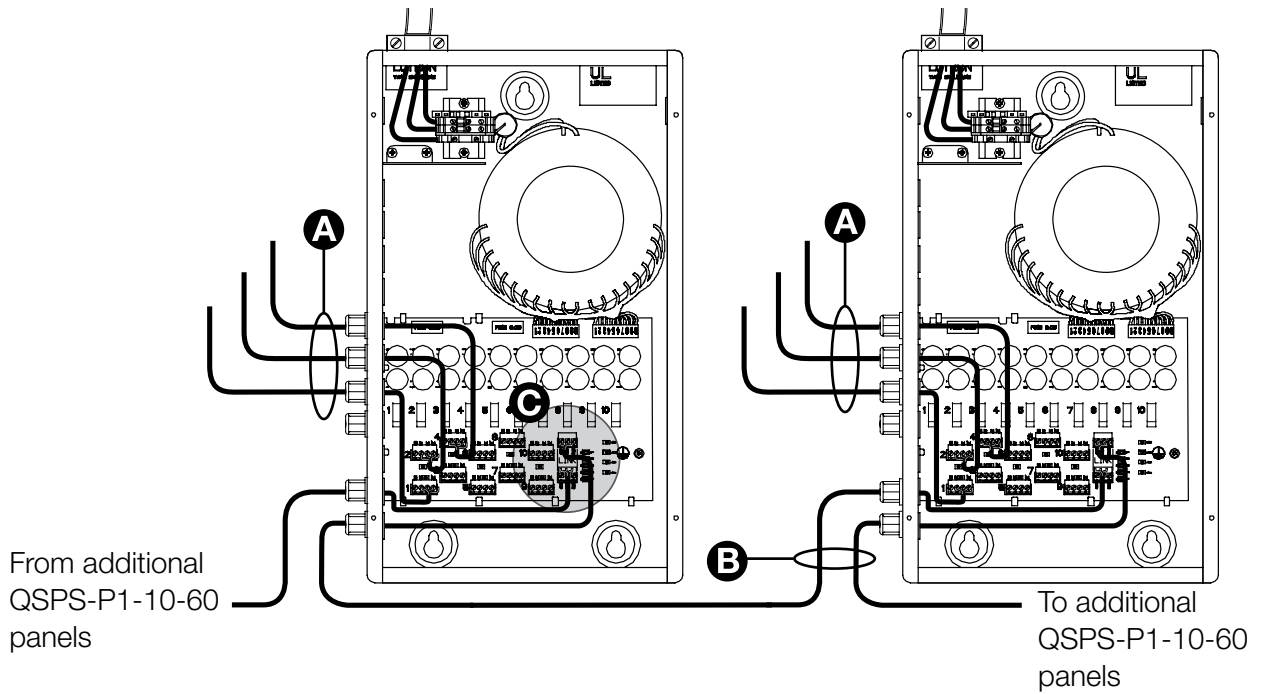

- A Device Link**
4 - conductor power and communications to devices.
Max 2,000 ft. (600 m) per QSPS-P1-10-60

- B Panel Link**
3 - conductor communications
Max 2,000 ft. (600 m) connecting all QSPS-P1-10-60 panels.

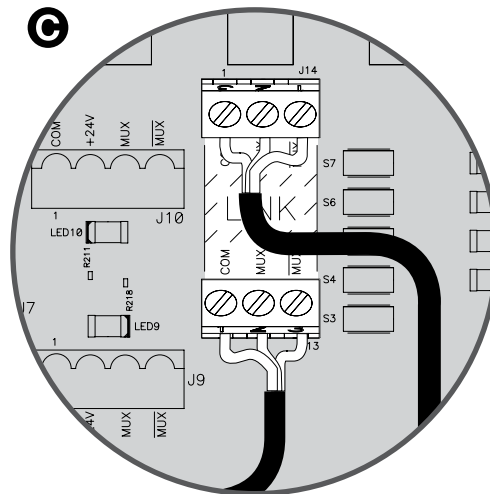

5 Diagnostics

The QSPS-P1-10-60 provides built-in diagnostics to help troubleshoot and verify your installation.

5.1 Output status LEDs

Each output has a status LED to indicate if the output is properly powered. If an output becomes overloaded, its status LED will blink to indicate the fault condition. Press the “Power Supply Clear” button after the fault condition has been cleared and the LED will stop blinking.

A Output status LEDs

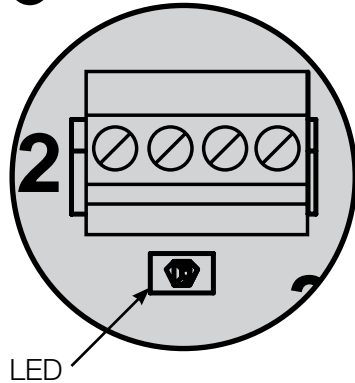

If an output status LED has turned off, the fuse will need to be replaced. The QSPS-P1-10-60 comes with two spare 5x20 mm 2.5A fuses.

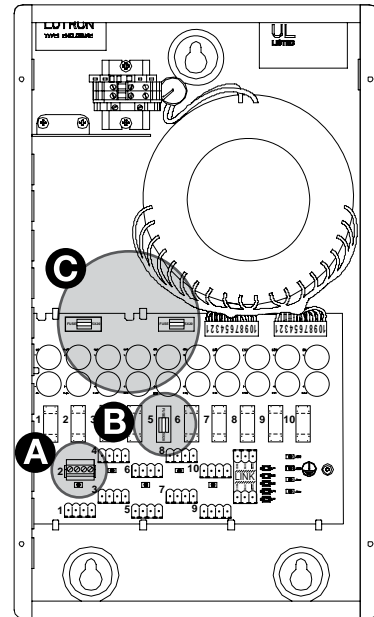

B Fuses

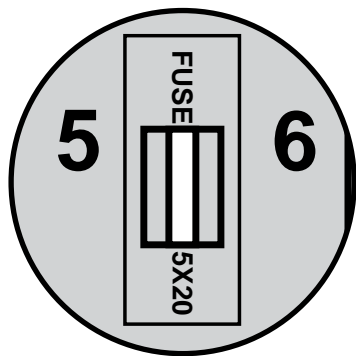

C Spare fuses

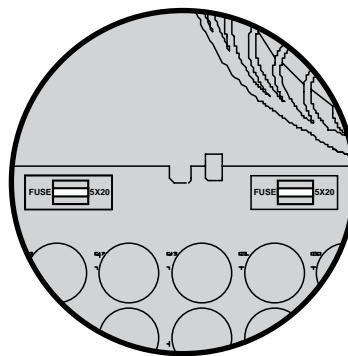

5 Diagnostics (continued)

5.2 Communications Link LEDs

The QSPS-P1-10-60 has four diagnostic LEDs for the communications link.

A Diagnostic LEDs

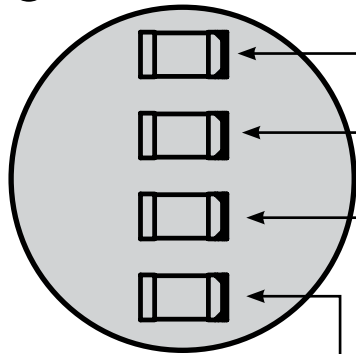

Reserved for future use

Reserved for future use

Link Traffic

This LED will blink green to indicate that devices are communicating.

Status LED

This LED indicates that the panel is operating properly. If this LED is off, check your wiring.

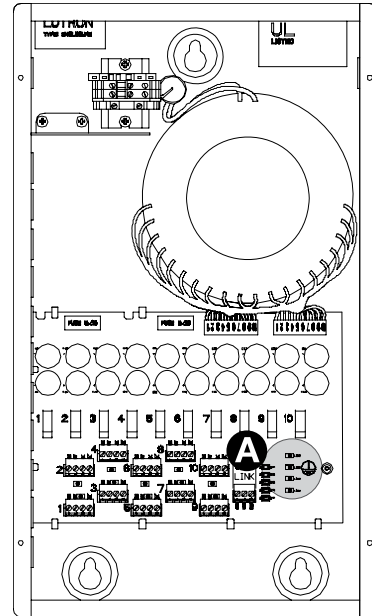

5 **Diagnostics** (continued)

5.3 **Verify Communications**

To verify the communications of your system, tap, hold, tap, hold the All Shades Open button. The QSPS-P1-10-60 is now trying to communicate with all other devices. All EDUs communicating on the link will wiggle and flash their green LED quickly. If you discover any EDUs that are not wiggling, verify that the EDU is powered and wired properly. Link Diagnostics Mode will automatically time out after 10 minutes.

To exit Link Diagnostics Mode, press and hold the All Shades Open button for 5 seconds.

Limited Warranty

SCOPE

This limited warranty (“Warranty”) covers the Lutron supplied (a) Sivoia® QS Shade System (“Sivoia® QS Shade System”), (b) Sivoia QED™ Shade System (“Sivoia QED™ Shade System”), (c) manual shade system and (d) alternating current or a/c shade system (each of the foregoing being a “System”). Customer acknowledges and agrees that use of the System constitutes acceptance of all terms and conditions of this Warranty.

LIMITED WARRANTY

Subject to the exclusions and restrictions described below, Lutron warrants that each System will be free from manufacturing defects from the date of shipment by Lutron for a period of (a) one year as to the wall controls, interfaces and system accessories of the Sivoia® QS Shade System (“External Sivoia® QS Components”) and (b) eight years as to the other Systems and the electronic drive unit, shade fabric and shade hardware of the Sivoia® QS Shade System. If any manufacturing defect exists in the External Sivoia® QS Components, so long as Customer promptly notifies Lutron of the defect within the one year warranty period and, if requested by Lutron, returns the defective part(s), Lutron will, at its option, either repair the defective part(s) or provide comparable replacement part(s). If any manufacturing defect exists in any of the components of a System other than the External Sivoia® QS Components, so long as Customer promptly notifies Lutron of the defect within the eight year warranty period and, if requested by Lutron, returns the defective part(s), Lutron will, at its option, either repair the defective part(s) or issue a credit to the Customer against the purchase price of comparable replacement part(s) purchased from Lutron as provided below:

Number of years from date of shipment	Percentage of cost of replacement parts credited by Lutron
Up to 2	100%
More than 2 but not more than 5	50%
More than 5 but not more than 8	25%
More than 8	0%

Replacement parts for the System provided by Lutron or, at its sole discretion, an approved vendor may be new, used, repaired, reconditioned, and/or made by a different manufacturer.

EXCLUSIONS AND RESTRICTIONS

This Warranty will be void, and Lutron and its suppliers will have no responsibility under this Warranty, if Lutron or its representatives cannot access any components of the System to inspect, diagnose problems with or repair the System or any of its components as a result of concealment or inaccessibility of such components within a building structure.

This Warranty does not cover, and Lutron and its suppliers are not responsible for:

1. Damage, malfunction or inoperability diagnosed by Lutron or a Lutron approved third party as caused by normal wear and tear, abuse, misuse, incorrect installation, neglect, accident, interference or environmental factors, such as (a) use of incorrect line voltages fuses or circuit breakers; (b) failure to install, maintain and operate the System pursuant to the operating instructions provided by Lutron and the applicable provisions of the National Electrical Code and of the Safety Standards of Underwriter’s Laboratories; (c) use of incompatible devices or accessories; (d) improper or insufficient ventilation; (e) unauthorized repairs or adjustments or alterations; (f) vandalism; (g) an act of God, such as fire, lightning, flooding, tornado, earthquake, hurricane or other problems beyond Lutron’s control; or (h) direct exposure to corrosive materials.
2. On-site labor costs to diagnose issues with, and remove, repair, replace, adjust, reinstall and/or reprogram the System or any of its components.
3. Components and equipment external to the System, such as, non-Lutron lighting and automation systems; building wiring audio-visual equipment; and non-Lutron time clocks, photosensors and motion detectors.
4. The cost of repairing or replacing other property that is damaged when any System does not work properly, even if the damage was caused by the System.

THIS WARRANTY IS IN LIEU OF ALL OTHER EXPRESS WARRANTIES. ALL IMPLIED WARRANTIES, INCLUDING THE IMPLIED WARRANTIES OF MERCHANTABILITY AND OF FITNESS FOR A PARTICULAR PURPOSE, ARE LIMITED TO EIGHT YEARS FROM THE DATE OF SHIPMENT, EXCEPT THAT SUCH IMPLIED WARRANTIES ARE LIMITED TO ONE YEAR FROM THE DATE OF SHIPMENT AS TO THE EXTERNAL Sivoia QS COMPONENTS.

NO LUTRON AGENT, EMPLOYEE OR REPRESENTATIVE HAS ANY AUTHORITY TO BIND LUTRON TO ANY AFFIRMATION, REPRESENTATION OR WARRANTY CONCERNING THE SYSTEMS. UNLESS AN AFFIRMATION, REPRESENTATION OR WARRANTY MADE BY AN AGENT, EMPLOYEE OR REPRESENTATIVE IS SPECIFICALLY INCLUDED HEREIN, OR IN STANDARD PRINTED MATERIALS PROVIDED BY LUTRON, IT DOES NOT FORM A PART OF THE BASIS OF ANY BARGAIN BETWEEN LUTRON AND CUSTOMER AND WILL NOT IN ANY WAY BE ENFORCEABLE BY CUSTOMER.

IN NO EVENT WILL LUTRON OR ANY OTHER PARTY BE LIABLE FOR EXEMPLARY, CONSEQUENTIAL, INCIDENTAL OR SPECIAL DAMAGES (INCLUDING, BUT NOT LIMITED TO DAMAGES FOR PERSONAL INJURY, FAILURE TO MEET ANY DUTY, INCLUDING OF GOOD FAITH OR REASONABLE CARE, NEGLIGENCE, OR ANY OTHER LOSS WHATSOEVER), NOR FOR ANY REPAIR WORK UNDERTAKEN WITHOUT LUTRON'S PRIOR WRITTEN CONSENT ARISING OUT OF OR IN ANY WAY RELATED TO THE INSTALLATION, DEINSTALLATION, USE OF OR INABILITY TO USE THE SYSTEM OR OTHERWISE UNDER OR IN CONNECTION WITH ANY PROVISION OF THIS WARRANTY, EVEN IN THE EVENT OF THE FAULT, TORT (INCLUDING NEGLIGENCE), STRICT LIABILITY, BREACH OF CONTRACT OR BREACH OF WARRANTY OF LUTRON OR ANY OTHER PARTY, AND EVEN IF LUTRON OR SUCH OTHER PARTY WAS ADVISED OF THE POSSIBILITY OF SUCH DAMAGES.

NOTWITHSTANDING ANY DAMAGES THAT CUSTOMER MIGHT INCUR FOR ANY REASON WHATSOEVER (INCLUDING, WITHOUT LIMITATION, ALL DIRECT DAMAGES AND ALL DAMAGES LISTED ABOVE), THE ENTIRE LIABILITY OF LUTRON AND OF ALL OTHER PARTIES UNDER THIS WARRANTY ON ANY CLAIM FOR DAMAGES ARISING OUT OF OR IN CONNECTION WITH THE MANUFACTURE, SALE, INSTALLATION, DELIVERY, USE, REPAIR, OR REPLACEMENT OF THE SYSTEM, AND CUSTOMER'S SOLE REMEDY FOR THE FOREGOING, WILL BE LIMITED TO THE AMOUNT PAID BY CUSTOMER FOR THE SYSTEM. THE FOREGOING LIMITATIONS, EXCLUSIONS AND DISCLAIMERS WILL APPLY TO THE MAXIMUM EXTENT ALLOWED BY APPLICABLE LAW, EVEN IF ANY REMEDY FAILS ITS ESSENTIAL PURPOSE.

THIS WARRANTY GIVES YOU SPECIFIC LEGAL RIGHTS. YOU MAY ALSO HAVE OTHER RIGHTS WHICH VARY FROM STATE TO STATE. SOME STATES DO NOT ALLOW LIMITATIONS ON HOW LONG AN IMPLIED WARRANTY LASTS OR THE EXCLUSION OR LIMITATION OF INCIDENTAL OR CONSEQUENTIAL DAMAGES, SO THE ABOVE LIMITATIONS OR EXCLUSIONS MAY NOT APPLY TO YOU.

WARRANTY CLAIMS, TECHNICAL ASSISTANCE AND WARRANTY INFORMATION.

Contact the Lutron Technical Support Center at the numbers provided below or your local Lutron sales representative with questions concerning the installation or operation of the System or this Warranty, or to make a warranty claim. Please provide the exact model number when calling.

U.S. and foreign patents pending.

Lutron, the Sunburst logo, and Sivoia QS are registered trademarks, and Sivoia QS and "Lighting Controls" are trademarks of Lutron Electronics Co., Inc.

Technical Assistance

WORLD HEADQUARTERS

Lutron Electronics Co., Inc.
7200 Suter Road
Coopersburg, PA 18036
United States
Tel: +1-610-282-3800
Fax: +1-610-282-1243

ASIAN HEADQUARTERS

Lutron GL Ltd.
15 Hoe Chiang Road
#07-03 Tower Fifteen
Singapore 089316
Tel: +65-6220-4666
Fax: +65-6220-4333
lutronsea@lutron.com

EUROPEAN HEADQUARTERS

Lutron EA Ltd.
6 Sovereign Close
London, E1W 3JF
United Kingdom
Tel: +44-(0)20-7702-0657
Fax: +44-(0)20-7480-6899

CUSTOMER SERVICE/ ORDERING

UK +44-(0)20-7702-0657 –
09.00 - 18.00 GMT
USA +1-610-282-3800 –
08.00 - 20.00 EST

CUSTOMER SERVICE /E-MAIL

shadinginfo@lutron.com

TECHNICAL SUPPORT & SERVICES

USA +1-610-282-3800 –
24 hours/7 days
UK +44-(0)20-7702-0657
09.00 - 18.00 GMT

INTERNET:

www.lutron.com

ADDITIONAL LUTRON SALES OFFICES:

Germany

Tel: +49-309-710-4590
Fax: +49-309-710-4591
FREEPHONE
00800-5887 6635

France

Lutron Ltc, S.A.R.L.-Paris
90 rue Villiers
92300 Levallois Perret,
France
Tel: +33-1-41-05-42-80
Fax: +33-1-41-05-01-80
FREEPHONE: 0800.90.12.18
lutronfrance@lutron.com

Spain-Madrid

Tel: +34-91-567-84-79
Fax: +34-91-567-84-78
FREEPHONE 0900-948-944

Spain-Barcelona

Tel: +34-93-496-57-42
Fax: +34-93-496-57-50
FREEPHONE 0900-948-944

Hong Kong

Tel: +852-2104-7733
Fax: +852-2104-7633

Beijing

Tel: +86-10-5877-1817
Fax: +86-10-5877-1816

Singapore

LUTRON GL Ltd. -
Singapore
15 Hoe Chiang Road
#7-03 Tower 15
Singapore 089316
Tel: +65-6220-4666
Fax: +65-6220-4333

Japan

Tel: +81-3-5575-8411
Fax: +81-3-5575-8420

www.lutron.com/shadingsolutions

USA and Canada (24 hrs/7days):
call: 800-523-9466

Other countries (8 a.m. – 8 p.m. ET)
call: +1-610-282-3800
fax: +1-610-282-3090

email: shadinginfo@lutron.com

©2007 LUTRON Electronics Co., Inc.

Printed in the U.S.A.

P/N 045-127 REV. B



Lutron® | QS Link Power Supply (QSPS-P1-1-50 / QSPS-P2-1-50 / QSPS-P3-1-50, 100-240 V~ 50/60 Hz
1 A Input Current) Installation Instructions

Tools Required: Wire cutter/stripper, small flat-head screwdriver
Optional: Power drill, mounting screws

1 Important Notes: Adherence to these specifications is necessary to ensure a safe and successful installation.

- All wiring must be in accordance with national and local electrical codes.
- Power supply should be installed by a qualified electrician.
- Ambient operating temperature: 32 °F to 104 °F (0 °C to 40 °C), 0 to 90% humidity, non-condensing.
- This product is intended for **indoor use only**.
- In Canada, separate over current protection is required, to be in accordance with Canadian Electrical Code, Part 1.

2 Installation

- The power supply may be surface mounted by using the mounting tabs if desired.

 - Unplug line voltage cable of the power supply before wiring low voltage terminal blocks.

2. Parts identification

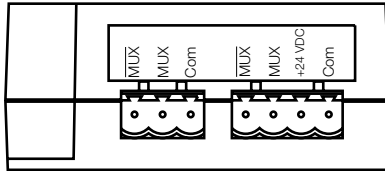
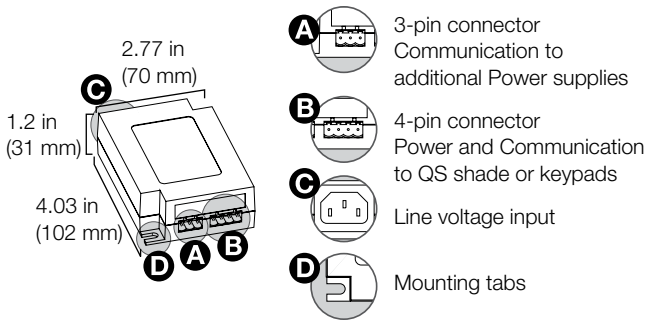

3 QS Link Wiring

- Link Rules** -The following link rules must be observed for proper operation.
 - Use only cable with at least one twisted/shielded pair for communications (MUX and MUX)
 - Total length of power supply link (A) wire plus device link (B) wire in entire system must be less than 2000 ft. (609 m)

Maximum devices powered from one QSPS-P1-1-50		Total wire length of link (B) based on wire gauge		
Shades	Controls	#12 AWG (4 mm ²)	#16 AWG (1.5 mm ²)	#18 AWG (1 mm ²) GRX-CBL-346S-500
1 Sivoia QS shade	None	250 ft. (75 m)	100 ft. (30 m)	50 ft. (17 m)
None	Up to 8 seeTouch® QS keypads*	1200 ft. (350 m)	500 ft. (150 m)	300 ft. (75 m)

* 2 seeTouch QS keypads may be exchanged for 1 control interface (QSE-CI-NWK-E)

4 Wiring the power supply

1. Run low voltage wire into the power supply

- Run the low-voltage communication wiring from the Lutron QS shade or keypads to the power supply (B).
- Strip insulation wire so that 0.25 in. (7 mm) of bare wire is exposed. Make sure to tighten the screws tightly and that no insulation is inside of the terminal block.
- Connect each wire to appropriate terminal block.
*Note: Terminal blocks are removable for ease of wiring.

2. Connecting multiple power supplies

- Use the 3-pin terminal blocks when connecting communications (A) between multiple power supplies.

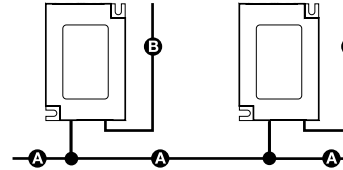

A: Power Supply Link (3-conductor)
Communications used to connect all power supplies.

B: Device Link (4-conductor)
Provides power and communications to devices.

3. Plug in line voltage and low voltage terminal blocks to power supply.

Example: Powering one shade
(max of one shade per output of a power supply)

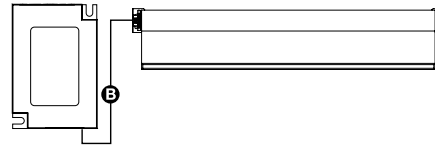

Example: Powering keypads

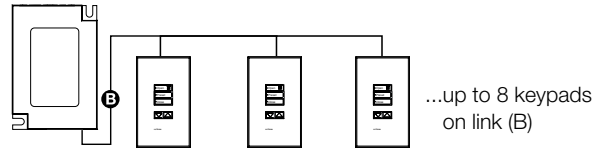

Example: Connecting to a GRAFIK Eye® QS

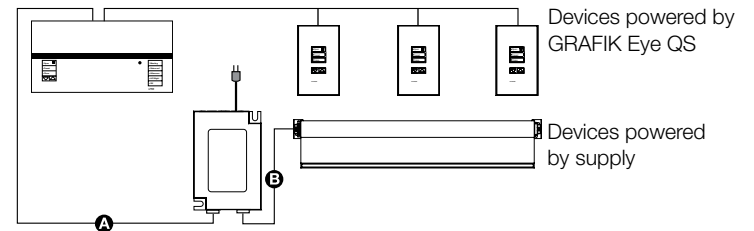

Example: Connecting to a GRAFIK Eye QS

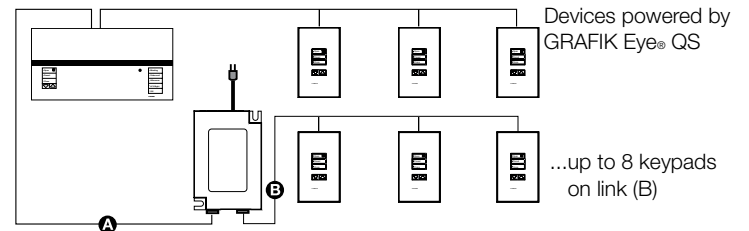

Limited Warranty

SCOPE

This limited warranty ("Warranty") covers the Lutron supplied (a) Sivoia® QS Shade System ("Sivoia® QS Shade System"), (b) Sivoia QED® Shade System ("Sivoia QED® Shade System"), (c) manual shade system and (d) alternating current or A/C shade system (each of the foregoing being a "System"). Customer acknowledges and agrees that use of the System constitutes acceptance of all terms and conditions of this Warranty.

LIMITED WARRANTY

Subject to the exclusions and restrictions described below, Lutron warrants that each System will be free from manufacturing defects from the date of shipment by Lutron for a period of (a) one year as to the wall controls, interfaces and system accessories of the Sivoia QS Shade System ("External Sivoia QS Components") and (b) eight years as to the other Systems and the Roller Shade EDU, shade fabric and shade hardware of the Sivoia QS Shade System. If any manufacturing defect exists in the External Sivoia QS Components, so long as Customer promptly notifies Lutron of the defect within the one year warranty period and, if requested by Lutron, returns the defective part(s), Lutron will, at its option, either repair the defective part(s) or provide comparable replacement part(s). If any manufacturing defect exists in any of the components of a System other than the External Sivoia QS Components, so long as Customer promptly notifies Lutron of the defect within the eight year warranty period and, if requested by Lutron, returns the defective part(s), Lutron will, at its option, either repair the defective part(s) or issue a credit to the Customer against the purchase price of comparable replacement part(s) purchased from Lutron as provided below:

Replacement parts for the System provided by Lutron or, at its sole discretion, an approved vendor may be new, used, repaired, reconditioned, and/or made by a different manufacturer.

Number of years from date of shipment	Percentage of cost of replacement parts credited by Lutron
Up to 2	100%
More than 2 but not more than 5	50%
More than 5 but not more than 8	25%
More than 8	0%

EXCLUSIONS AND RESTRICTIONS

This Warranty will be void, and Lutron and its suppliers will have no responsibility under this Warranty, if Lutron or its representatives cannot access any components of the System to inspect, diagnose problems with or repair the System or any of its components as a result of concealment or inaccessibility of such components within a building structure.

This Warranty does not cover, and Lutron and its suppliers are not responsible for:

1. Damage, malfunction or inoperability diagnosed by Lutron or a Lutron approved third party as caused by normal wear and tear, abuse, misuse, incorrect installation, neglect, accident, interference or environmental factors, such as (a) use of incorrect line voltages fuses or circuit breakers; (b) failure to install, maintain and operate the System pursuant to the operating instructions provided by Lutron and the applicable provisions of the National Electrical Code and of the Safety Standards of Underwriter's Laboratories; (c) use of incompatible devices or accessories; (d) improper or insufficient ventilation; (e) unauthorized repairs or adjustments or alterations; (f) vandalism; (g) an act of God, such as fire, lightning, flooding, tornado, earthquake, hurricane or other problems beyond Lutron's control; or (h) direct exposure to corrosive materials.
2. On-site labor costs to diagnose issues with, and remove, repair, replace, adjust, reinstall and/or reprogram the System or any of its components.
3. Components and equipment external to the System, such as, non-Lutron lighting and automation systems; building wiring audio-visual equipment; and non-Lutron time clocks, photosensors and motion detectors.
4. The cost of repairing or replacing other property that is damaged when any System does not work properly, even if the damage was caused by the System.

THIS WARRANTY IS IN LIEU OF ALL OTHER EXPRESS WARRANTIES. ALL IMPLIED WARRANTIES, INCLUDING THE IMPLIED WARRANTIES OF MERCHANTABILITY AND OF FITNESS FOR A PARTICULAR PURPOSE, ARE LIMITED TO EIGHT YEARS FROM THE DATE OF SHIPMENT, EXCEPT THAT SUCH IMPLIED WARRANTIES ARE LIMITED TO ONE YEAR FROM THE DATE OF SHIPMENT AS TO THE EXTERNAL SIVOIA QS COMPONENTS.

NO LUTRON AGENT, EMPLOYEE OR REPRESENTATIVE HAS ANY AUTHORITY TO BIND LUTRON TO ANY AFFIRMATION, REPRESENTATION OR WARRANTY CONCERNING THE SYSTEMS. UNLESS AN AFFIRMATION, REPRESENTATION OR WARRANTY MADE BY AN AGENT, EMPLOYEE OR REPRESENTATIVE IS SPECIFICALLY INCLUDED HEREIN, OR IN STANDARD PRINTED MATERIALS PROVIDED BY LUTRON, IT DOES NOT FORM A PART OF THE BASIS OF ANY BARGAIN BETWEEN LUTRON AND CUSTOMER AND WILL NOT IN ANY WAY BE ENFORCEABLE BY CUSTOMER.

IN NO EVENT WILL LUTRON OR ANY OTHER PARTY BE LIABLE FOR EXEMPLARY, CONSEQUENTIAL, INCIDENTAL OR SPECIAL DAMAGES (INCLUDING, BUT NOT LIMITED TO DAMAGES FOR PERSONAL INJURY, FAILURE TO MEET ANY DUTY, INCLUDING OF GOOD FAITH OR REASONABLE CARE, NEGLIGENCE, OR ANY OTHER LOSS WHATSOEVER), NOR FOR ANY REPAIR WORK UNDERTAKEN WITHOUT LUTRON'S PRIOR WRITTEN CONSENT ARISING OUT OF OR IN ANY WAY RELATED TO THE INSTALLATION, DEINSTALLATION, USE OF OR INABILITY TO USE THE SYSTEM OR OTHERWISE UNDER OR IN CONNECTION WITH ANY PROVISION OF THIS WARRANTY, EVEN IN THE EVENT OF THE FAULT, TORT (INCLUDING NEGLIGENCE), STRICT LIABILITY, BREACH OF CONTRACT OR BREACH OF WARRANTY OF LUTRON OR ANY OTHER PARTY, AND EVEN IF LUTRON OR SUCH OTHER PARTY WAS ADVISED OF THE POSSIBILITY OF SUCH DAMAGES.

NOTWITHSTANDING ANY DAMAGES THAT CUSTOMER MIGHT INCUR FOR ANY REASON WHATSOEVER (INCLUDING, WITHOUT LIMITATION, ALL DIRECT DAMAGES AND ALL DAMAGES LISTED ABOVE), THE ENTIRE LIABILITY OF LUTRON AND OF ALL OTHER PARTIES UNDER THIS WARRANTY ON ANY CLAIM FOR DAMAGES ARISING OUT OF OR IN CONNECTION WITH THE MANUFACTURE, SALE, INSTALLATION, DELIVERY, USE, REPAIR, OR REPLACEMENT OF THE SYSTEM, AND CUSTOMER'S SOLE REMEDY FOR THE FOREGOING, WILL BE LIMITED TO THE AMOUNT PAID BY CUSTOMER FOR THE SYSTEM. THE FOREGOING LIMITATIONS, EXCLUSIONS AND DISCLAIMERS WILL APPLY TO THE MAXIMUM EXTENT ALLOWED BY APPLICABLE LAW, EVEN IF ANY REMEDY FAILS ITS ESSENTIAL PURPOSE.

THIS WARRANTY GIVES YOU SPECIFIC LEGAL RIGHTS. YOU MAY ALSO HAVE OTHER RIGHTS WHICH VARY FROM STATE TO STATE. SOME STATES DO NOT ALLOW LIMITATIONS ON HOW LONG AN IMPLIED WARRANTY LASTS OR THE EXCLUSION OR LIMITATION OF INCIDENTAL OR CONSEQUENTIAL DAMAGES, SO THE ABOVE LIMITATIONS OR EXCLUSIONS MAY NOT APPLY TO YOU.

WARRANTY CLAIMS, TECHNICAL ASSISTANCE AND WARRANTY INFORMATION

Contact the Lutron Technical Support Center at the numbers provided below or your local Lutron sales representative with questions concerning the installation or operation of the System or this Warranty, or to make a warranty claim. Please provide the exact model number when calling.

The product may be covered under one or more of the following U.S. patents: 6,983,783; 7,281,565, and corresponding patents pending. U.S. and foreign patents pending.

Lutron, the Sunburst logo, Sivoia QED, GRAFIK Eye, and Sivoia are registered trademarks, and Sivoia QS is a trademark of Lutron Electronics Co., Inc.

www.lutron.com/shadingsolutions

USA and Canada (24 hrs/7 days): call: 800.523.9466

Other countries (8 a.m. – 8 p.m. ET) call: +1.610.282.3800

fax: +1.610.282.3090

email: shadinginfo@lutron.com

©2008 LUTRON Electronics Co., Inc.

P/N 030-979 REV. B



Worldwide headquarters

Lutron Electronics Co., Inc.
7200 Suter Road
Coopersburg, PA 18036-1299
USA
TEL: +1.610.282.3800
FAX: +1.610.282.1243
Toll-free: 1.888.LUTRON1
intsales@lutron.com

Asian headquarters

Lutron GL Ltd.
15 Hoe Chiang Road
#07-03 Euro Asia Centre
Singapore 089316
TEL: +65.6220.4666
FAX: +65.6220.4333
lutronsea@lutron.com

European headquarters

Lutron EA Ltd.
6 Sovereign Close
London, E1W 3JF
UK
TEL: +44.(0)20.7702.0657
FAX: +44.(0)20.7480.6899
FREEPHONE: 0800.282.107
lutronlondon@lutron.com

Brazil

Lutron BZ do Brasil, Ltda.
Avenida Brasil, 239
Jardim América
São Paulo - SP
CEP: 01431-001
Brazil
TEL: +55.11.3885.5152
FAX: +55.11.3887.7138
brasilsales@lutron.com

China, Beijing

Lutron GL Ltd.,
Beijing Representative Office
5th Floor, China Life Tower
No. 16 Chaowai St.
Chaoyang District
Beijing 100020, China
TEL: +86.10.5877.1818
FAX: +86.10.5877.1816
lutronchina@lutron.com

China, Guangzhou

Lutron GL Ltd.,
Guangzhou Representative Office
Suite A09
23/F Tower A, Centre Plaza
161 Lin He Xi Lu, Tian He District
Guangzhou 510620, China
TEL: +86.20.2885.8266
FAX: +86.20.2885.8366
lutronchina@lutron.com

China, Hong Kong

Lutron GL Ltd.,
Unit 2808, 28/F
248 Queen's Road East
Wanchai, Hong Kong, China
TEL: +852.2104.7733
FAX: +852.2104.7633
lutronhk@lutron.com

China, Shanghai

Lutron GL Ltd.,
Shanghai Representative Office
Suite 07, 39th Floor
Plaza 66
1266 Nan Jing West Road
Shanghai, 200040, China
TEL: +86.21.6288.1473
FAX: +86.21.6288.1751
lutronchina@lutron.com

France

Lutron LTC, S.A.R.L.
90 rue de Villiers
92300 Levallois-Perret, France
TEL: +33.(0)1.41.05.42.80
FAX: +33.(0)1.41.05.01.80
FREEPHONE: 0800.90.12.18
lutronfrance@lutron.com

Germany

Lutron Electronics GmbH
Landsberger Allee 201
13055 Berlin, Germany
TEL: +49.(0)30.9710.4590
FAX: +49.(0)30.9710.4591
FREEPHONE: 00800.5887.6635
lutrongermany@lutron.com

Italy

Lutron LDV S.r.l.
FREEPHONE: 800.979.208
lutronitalia@lutron.com

Japan

Lutron Asuka Co., Ltd.
No. 16 Kowa Building, 4F
1-9-20, Akasaka, Minato-ku
Tokyo 107-0052 Japan
TEL: +81.3.5575.8411
FAX: +81.3.5575.8420
FREEPHONE: 0120.083.417
asuka@lutron.com

Spain, Barcelona

Lutron CC, S.R.L.
Gran Vía Carlos III, 84, planta 3ª
08028 Barcelona, Spain
TEL: +34.93.496.57.42
FAX: +34.93.496.57.01
FREEPHONE: 0900.948.944
lutroniberia@lutron.com

Spain, Madrid

Lutron CC, S.R.L.
Calle Orense, 85
28020 Madrid, Spain
TEL: +34.91.567.84.79
FAX: +34.91.567.84.78
FREEPHONE: 0900.948.944
lutroniberia@lutron.com



Lutron controls your light.™

www.lutron.com

Lutron Electronics Co., Inc.
7200 Suter Road
Coopersburg, PA 18036-1299

World Headquarters 1.610.282.3800
Technical Support Center 1.800.523.9466
Customer Service 1.888.LUTRON1

© 06/2006 Lutron Electronics Co., Inc.